

# Centrifuge modelling of the response of shared anchors to multidirectional loading

---

Ricardo Zabatta, Christelle Abadie, Matthieu Blanc

[christelle.abadie@univ-eiffel.fr](mailto:christelle.abadie@univ-eiffel.fr) | [matthieu.blanc@univ-eiffel.fr](mailto:matthieu.blanc@univ-eiffel.fr)

In geotechnical engineering, why do we have to work on centrifuged small-scale models?

Prototype



Small-scale Model (1/N)



$$\sigma = \rho \cdot g \cdot (z/N)$$

$$\sigma = \rho \cdot (N \cdot g) \cdot (z/N)$$

Gustave Eiffel Geotechnical Centrifuge :  $R = 5.5$  m & capacity 200 t.g

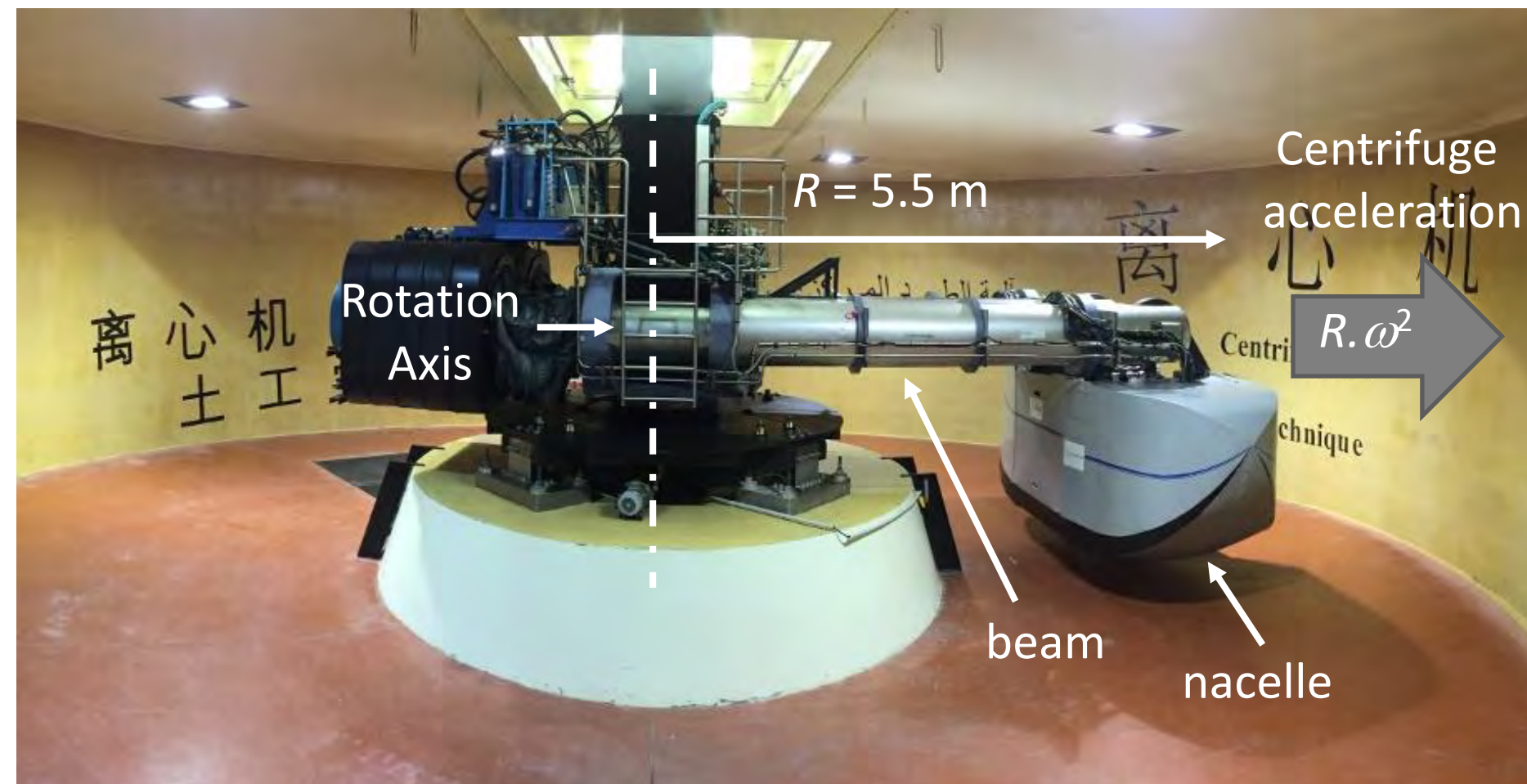

Centrifuge start



Centrifuge at 100 g (more than 2 turns per second)

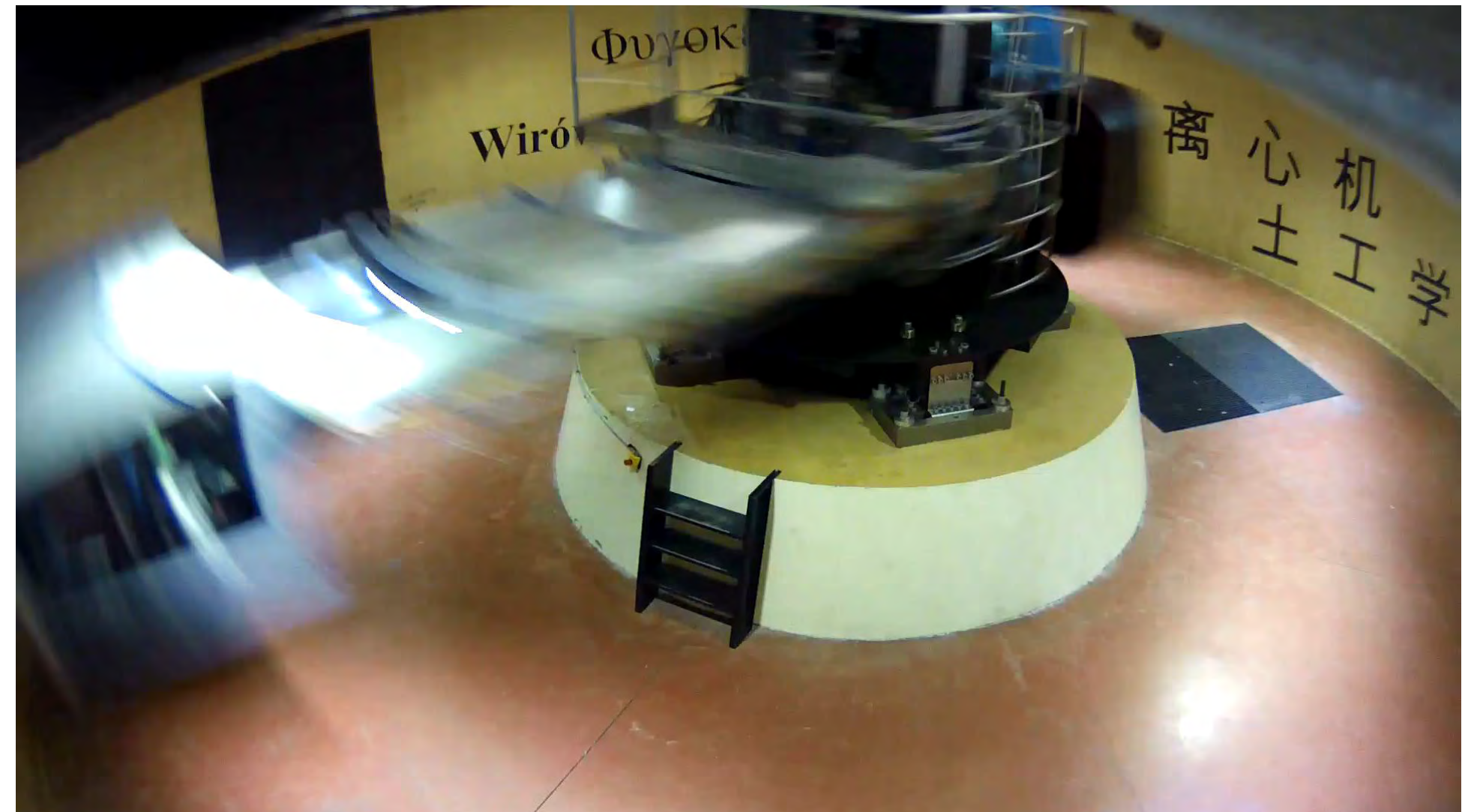

- In geotechnical engineering, why do we have to work on centrifuged small-scale models?
  - To conserve the same stress state in the prototype and in the small-scale model
- Why do we have to conserve this stress state ?
  - Because of the non-linearity of the behaviour of geomaterials

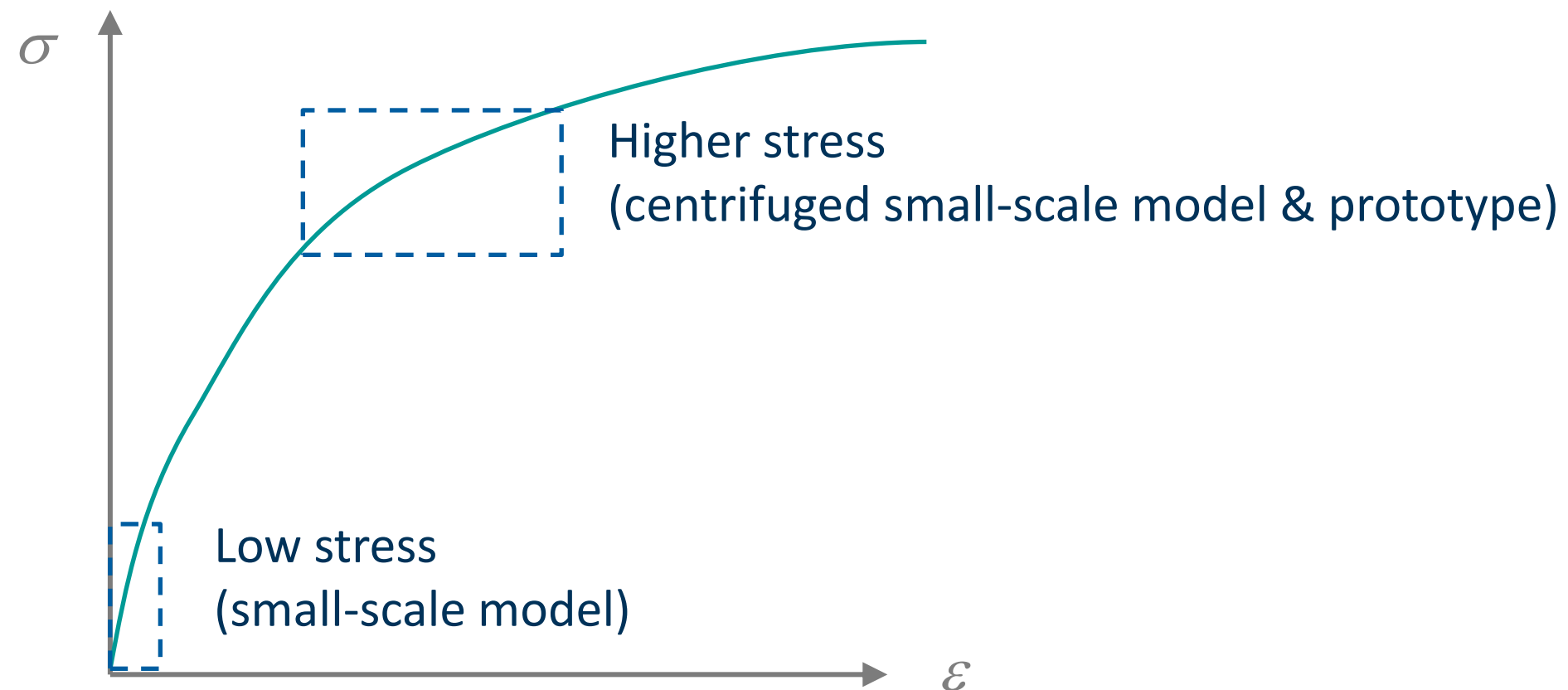

- **Advantages**

- Time (compared with in situ testing)
- Price (compared with in situ testing)
- Behaviour up to failure
- Controlled boundary conditions (soil)
- Reproducibility
- Instrumentation

- **Disadvantages**

- Time (compared with numerical modelling)
- Price (compared with numerical modelling)
- Difficulty in reproducing real soil
- Costly in terms of personnel

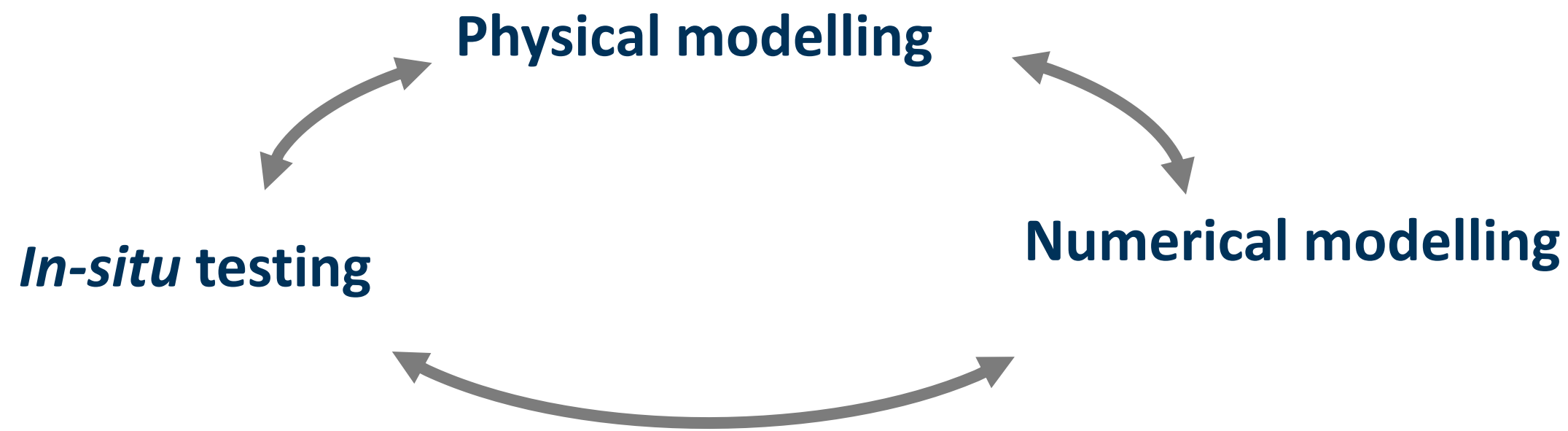

## General objective

Increase knowledge on multi-directional cyclic loading effects on shared anchor piles for floating wind turbines through centrifuge modelling

## 5 main objectives corresponding to deliverables

1. Develop and Validate a **new experimental set-up** for multi-directional loading of anchors
2. Understand key mechanisms driving pile response to **multi-directional loading**
3. Expand conclusions to **multi-directional Cyclic loading**
4. Compare with **numerical** analyses for validation and perspectives
5. Provide an **experimental database** for future work on shared anchor piles



# 1. Develop a new experimental set-up for multi-directional loading of anchors

## General objective

Increase knowledge on multi-directional cyclic loading effects on shared anchor piles for floating wind turbines through centrifuge modelling

## 5 main objectives corresponding to deliverables

1. Develop and Validate a **new experimental set-up** for multi-directional loading of anchors

2. Understand key mechanisms driving pile response to **multi-directional loading**
3. Expand conclusions to **multi-directional cyclic loading**
4. Compare with **numerical** analyses for validation and perspectives
5. Provide an **experimental database** for future work on shared anchor piles



# 1. Develop a new experimental set-up for multi-directional loading of anchors

Modelling shared anchors: a three mooring lines experimental set-up for the centrifuge

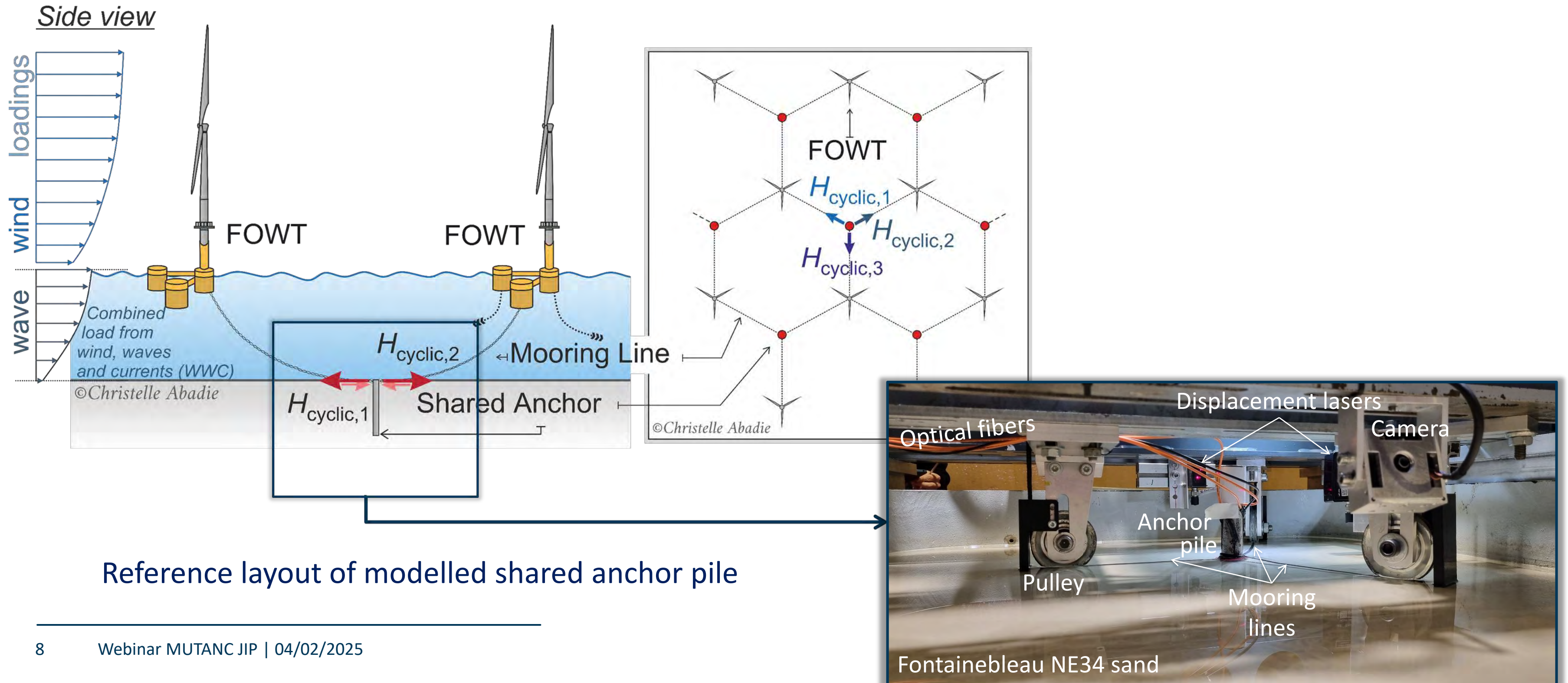

# 1. Develop a new experimental set-up for multi-directional loading of anchors

Modelling shared anchors: a three mooring lines experimental set-up for the centrifuge

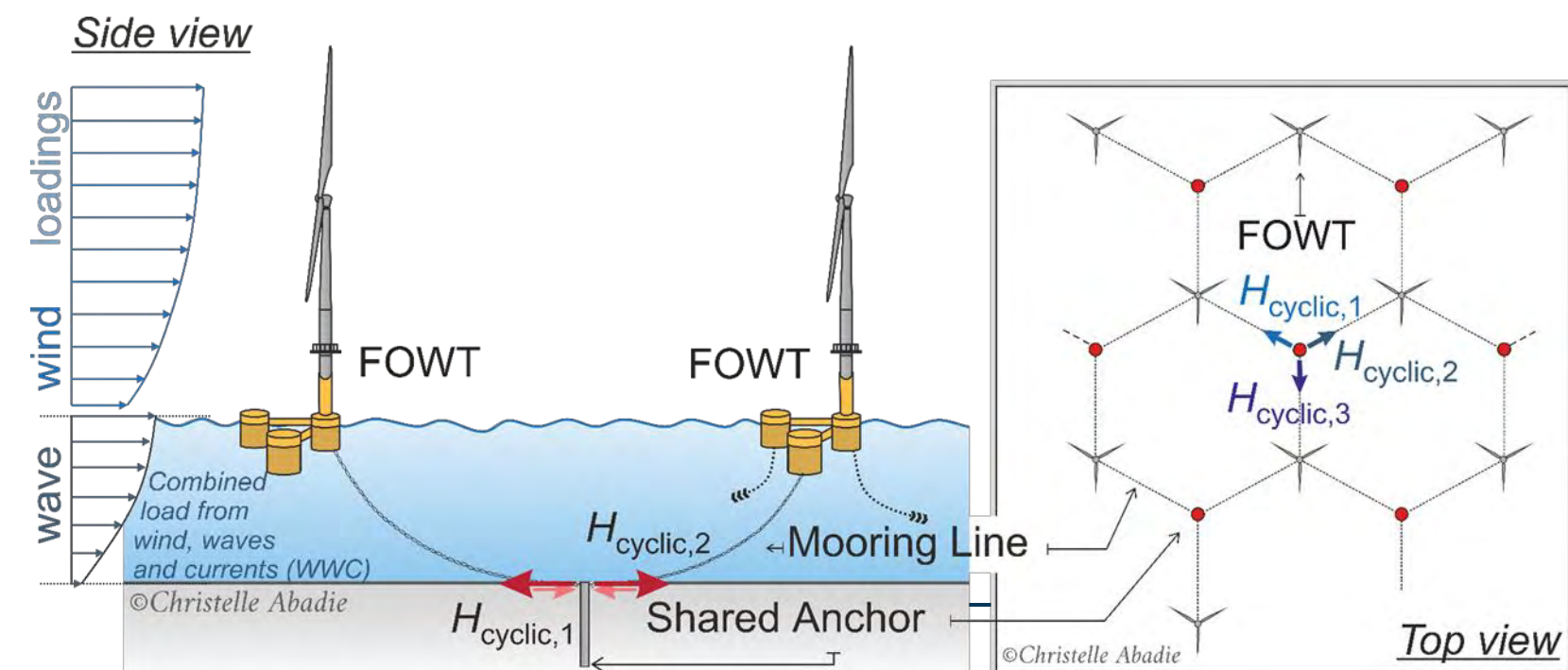
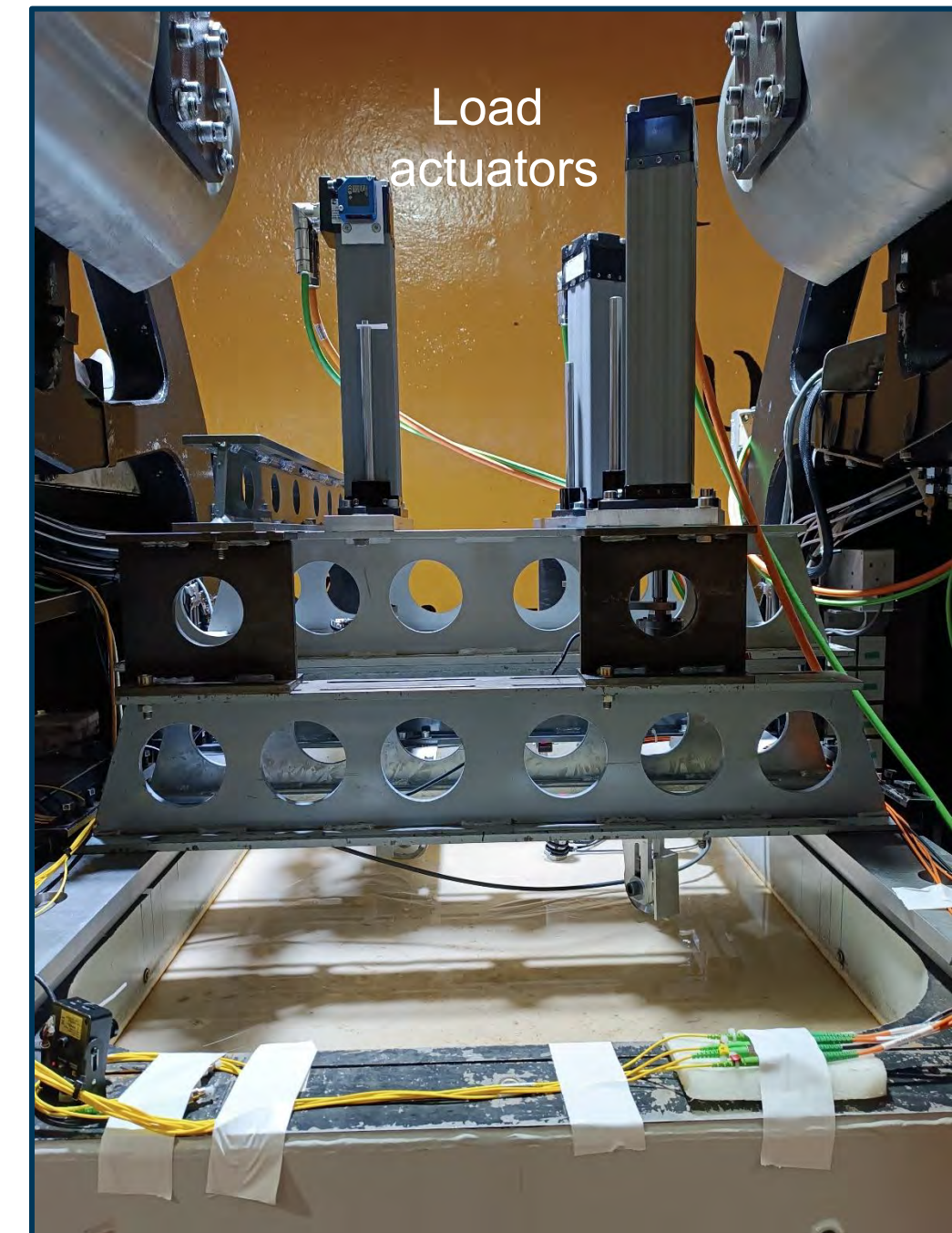
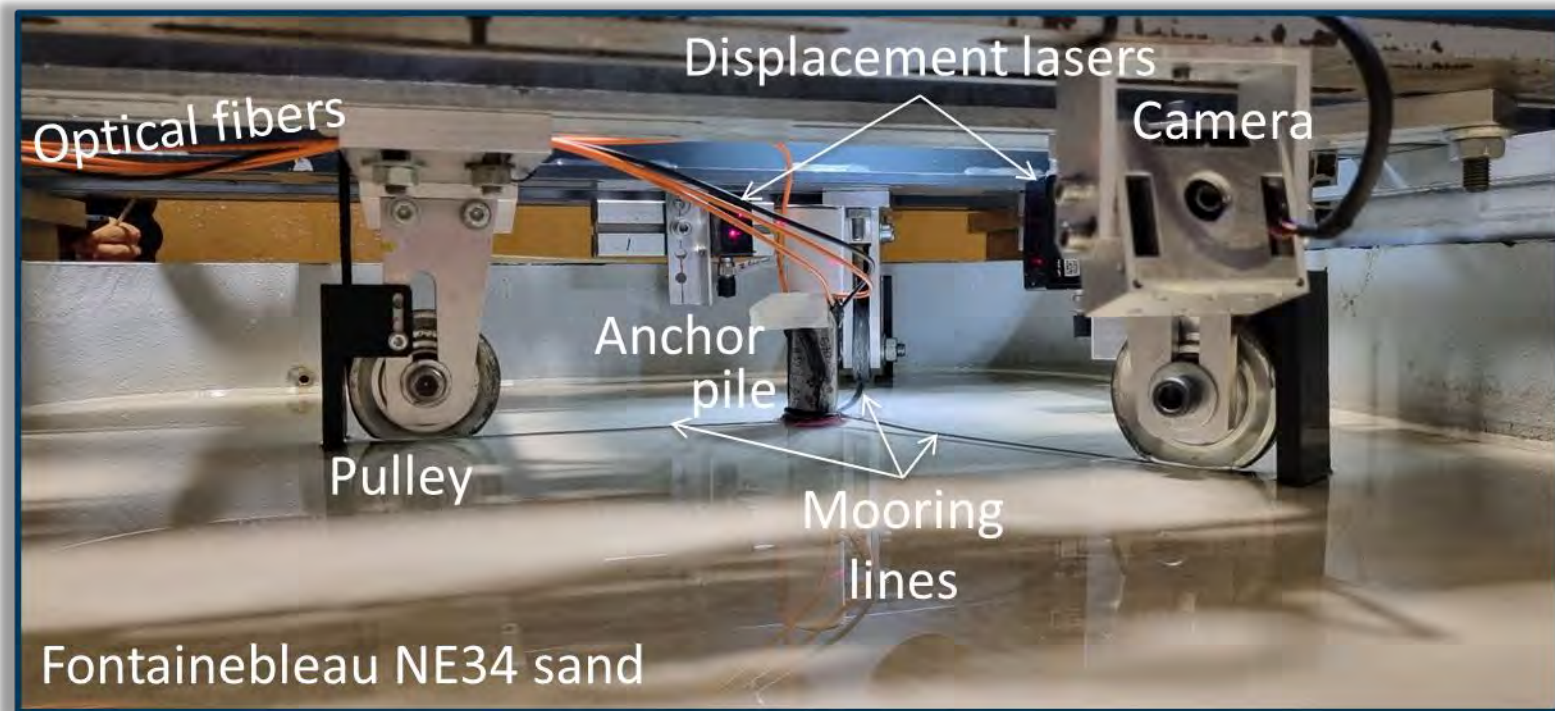

Reference layout of modelled shared anchor pile

# Develop a new experimental set-up for multi-directional loading of anchors

Load cell



Dyneema® cables for mooring lines



Load actuator

Moog digital controller



Distance laser



# Develop a new experimental set-up for multi-directional loading of anchors

## Overview of Experimental Campaigns: Container #1

**Objective:** To validate experimental set-up and obtain monotonic response

### Container 1

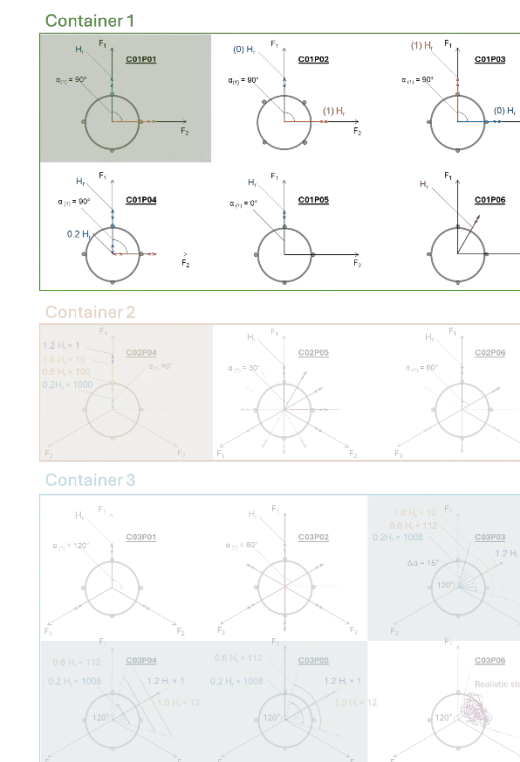
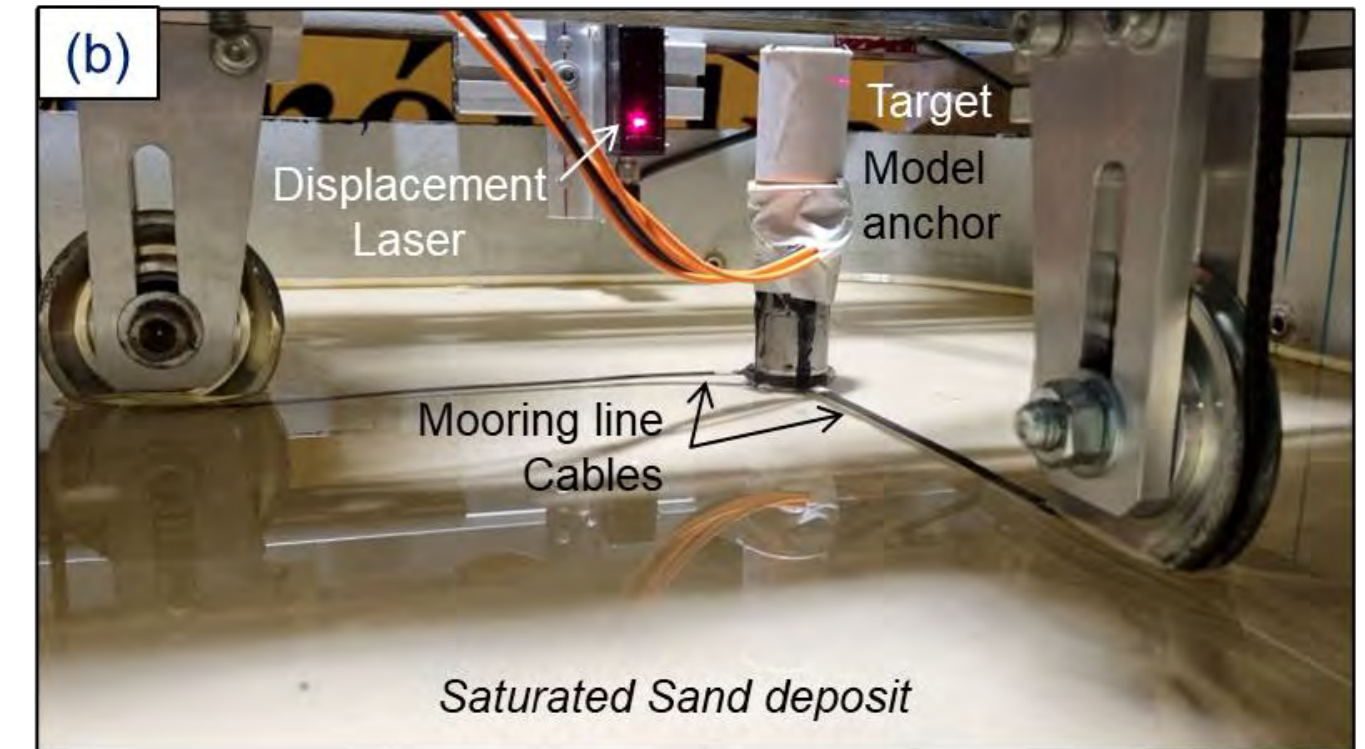
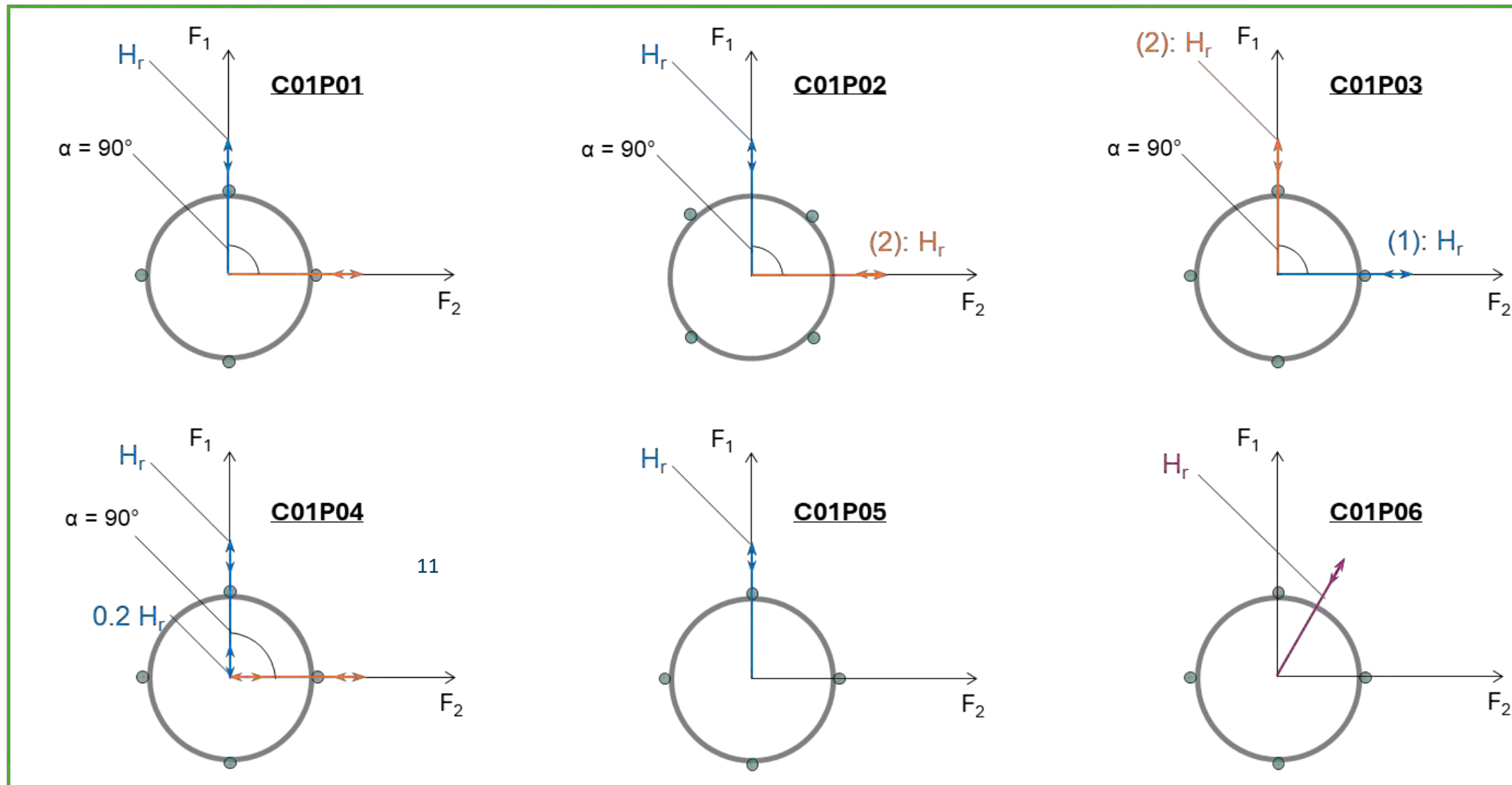

# Develop a new experimental set-up for multi-directional loading of anchors

## Overview of Experimental Campaigns: Containers #2 & 3

**Objective:** To establish pile response to #2 multi-directional monotonic loads and #3 multi-directional cyclic loads

### Container 2

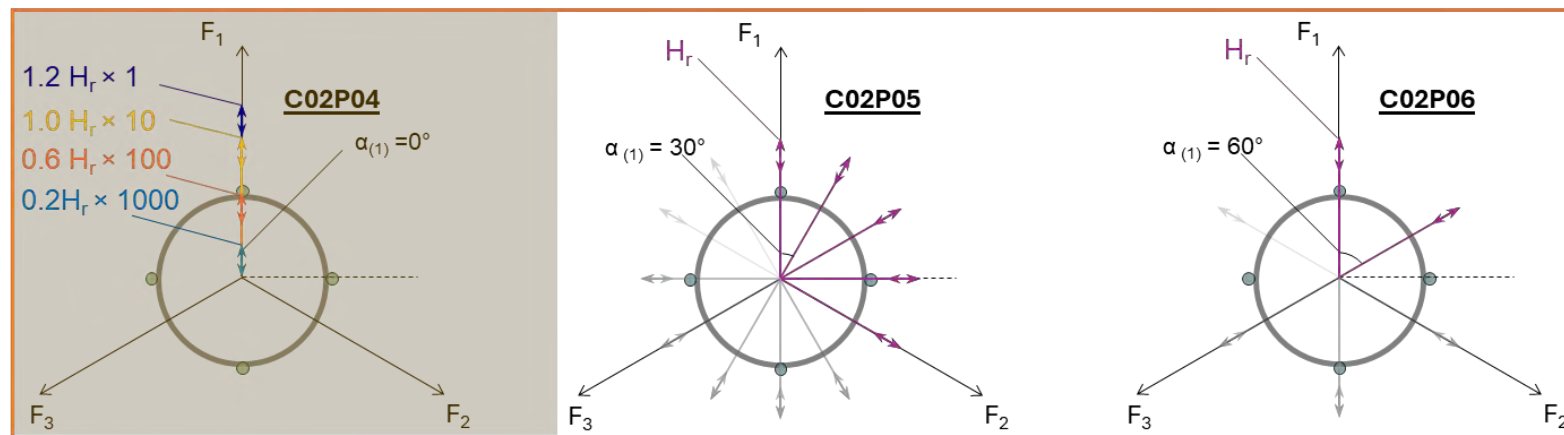

### Container 3

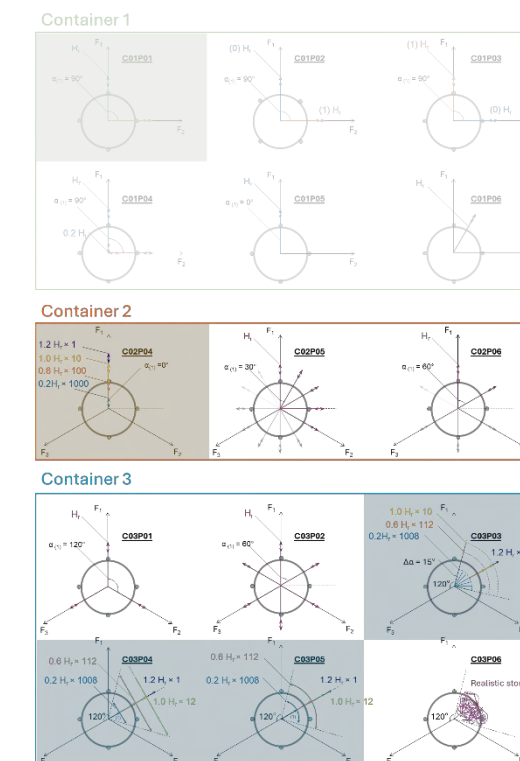
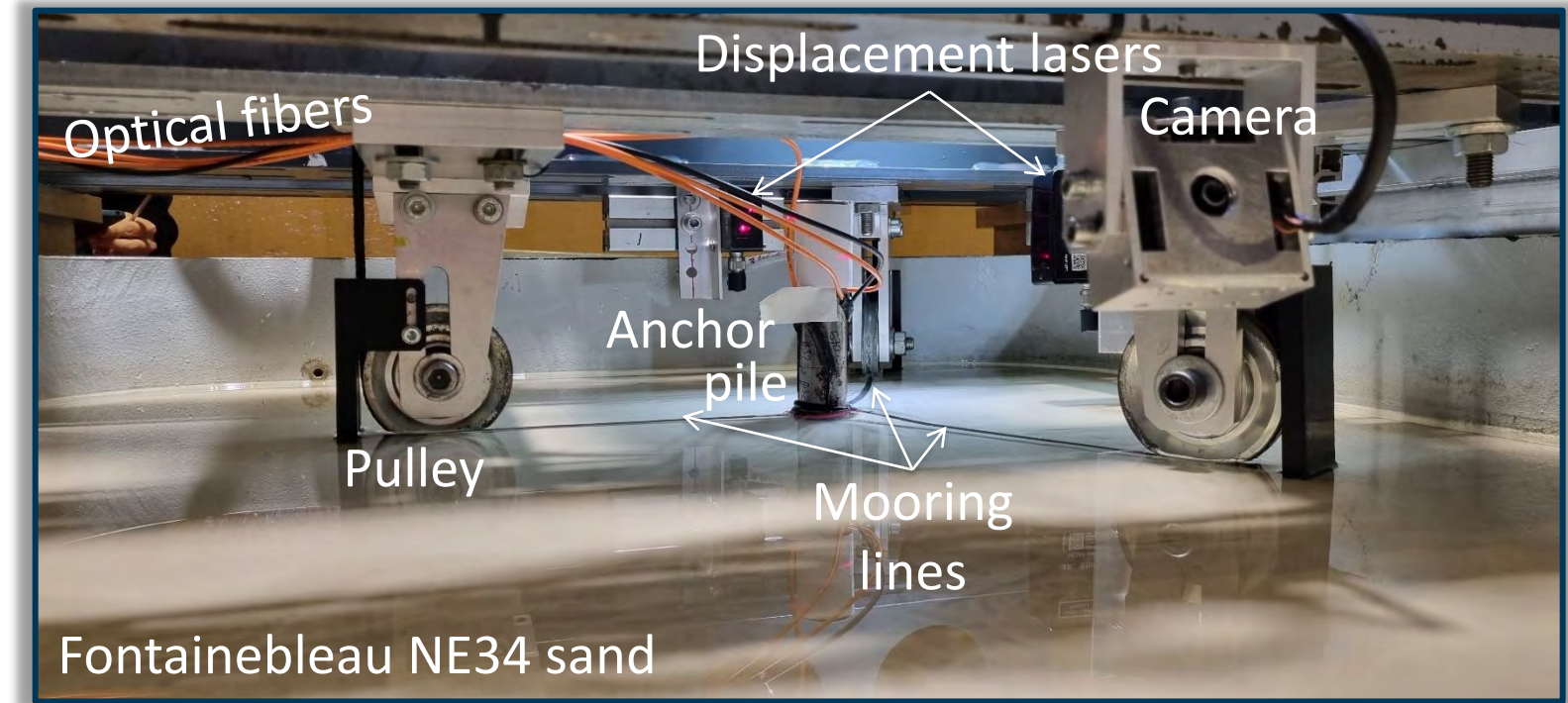
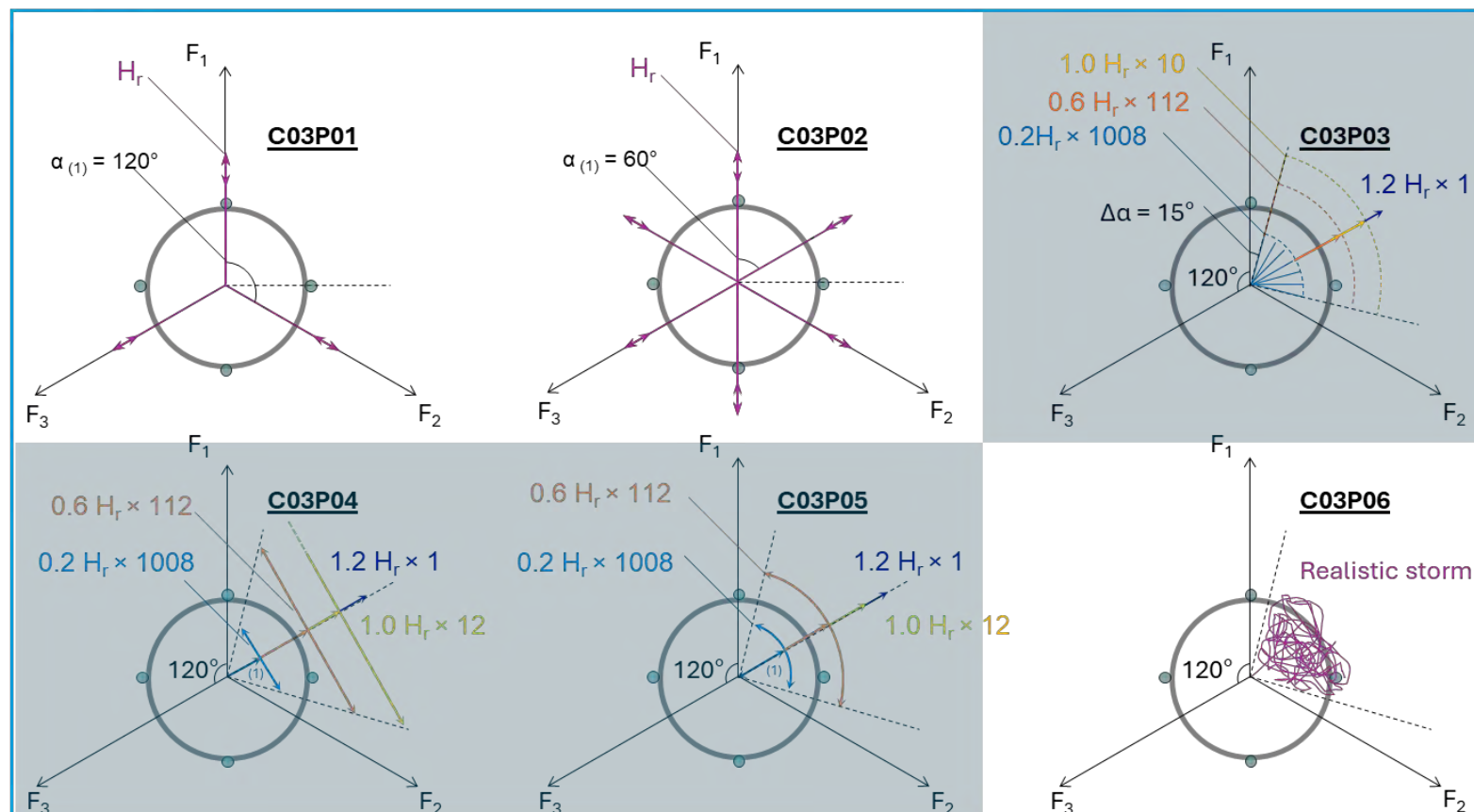

# Develop a new experimental set-up for multi-directional loading of anchors

Model pile: Tested at 83.3g

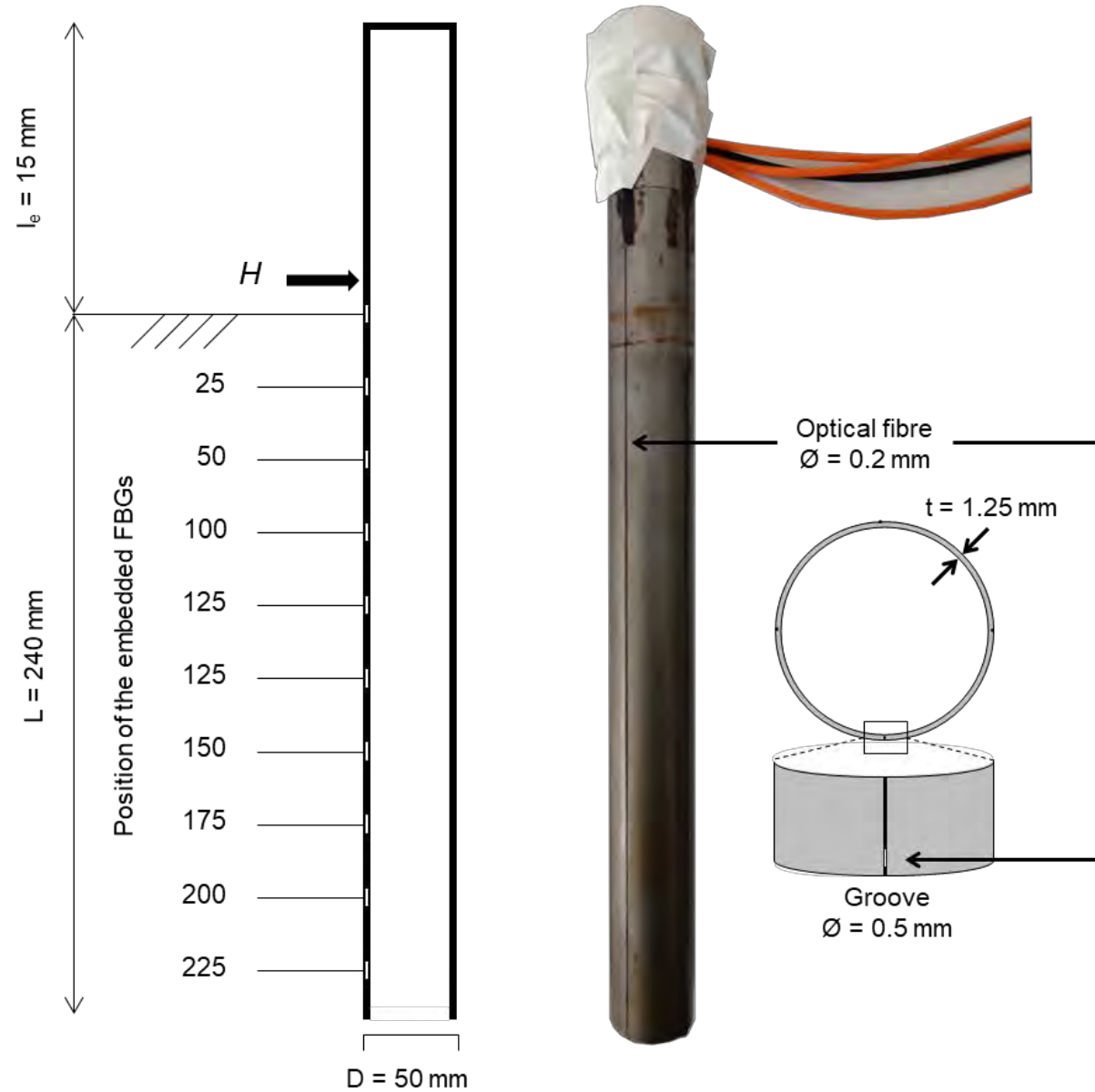

**FBG**  
 $\epsilon$   
 $E_{\text{pile}}$   
 $I_{\text{pile}}$   
**Fitting law**  
 boundary conditions:  
 $M|_{z=e} = F \times e$   
 $e = 0.5D$   
**Derivation**  
 $\frac{dM}{dz} = S(z)$   
 $\frac{d^2M}{dz^2} = P(z)$   
**Integration**  
 $\int_0^L \frac{M(z)}{EI} dz + C1 + C2 = y(z)$   
 (fitting function)

# Develop a new experimental set-up for multi-directional loading of anchors

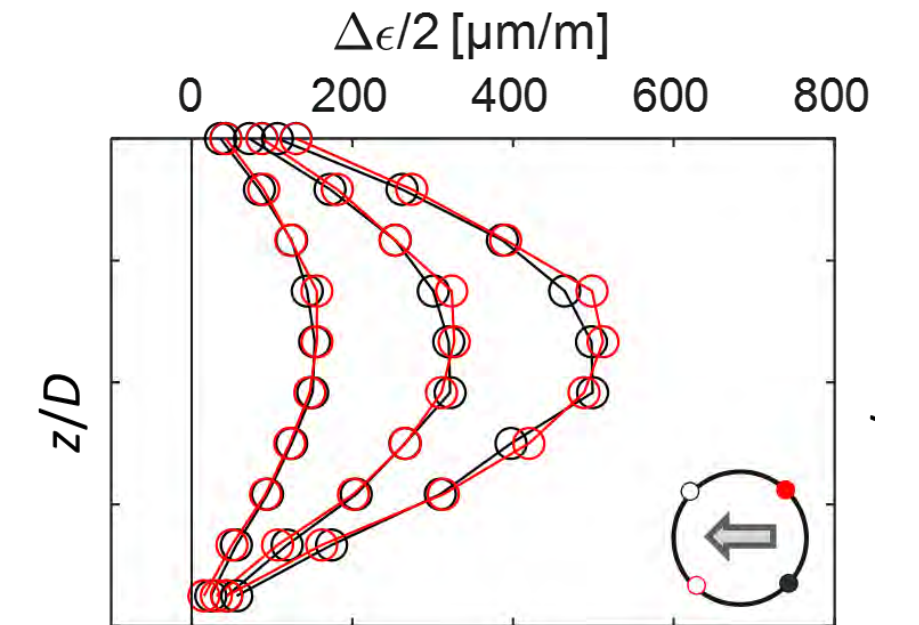
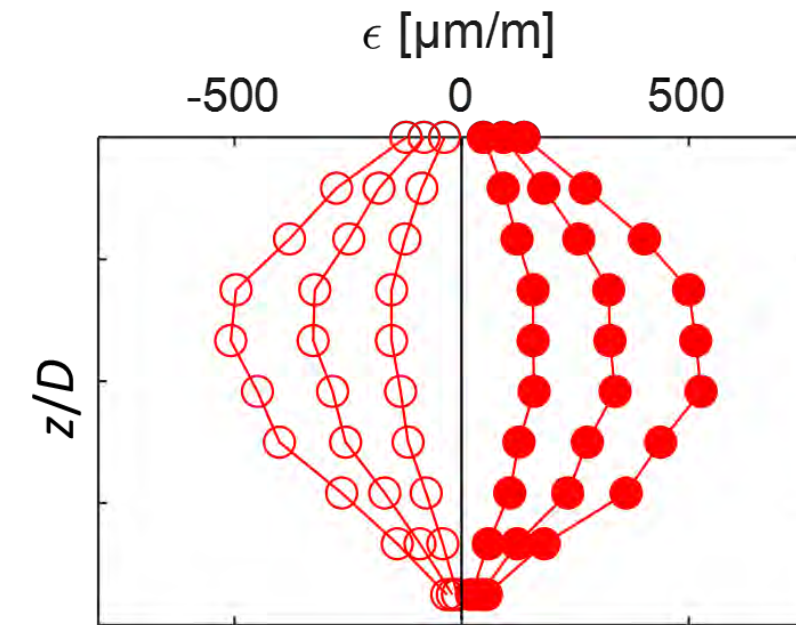
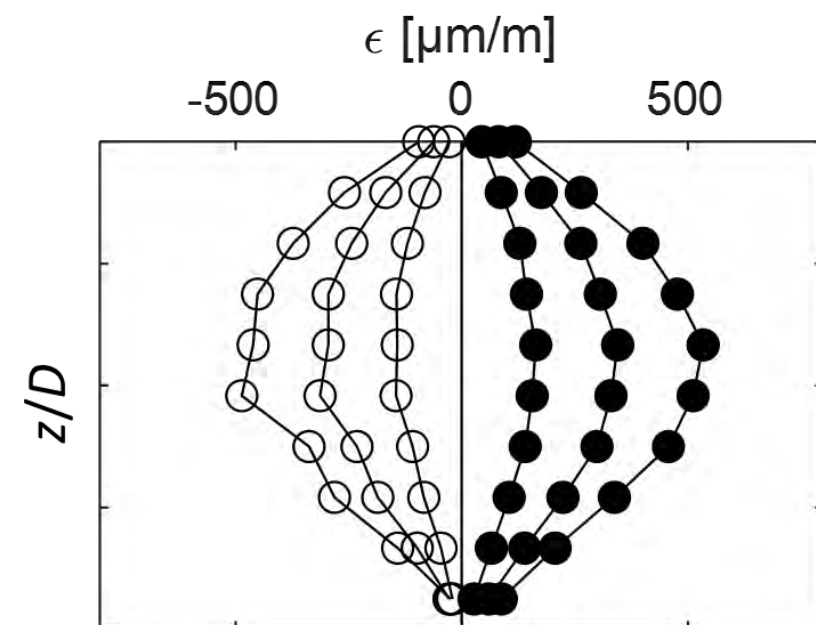
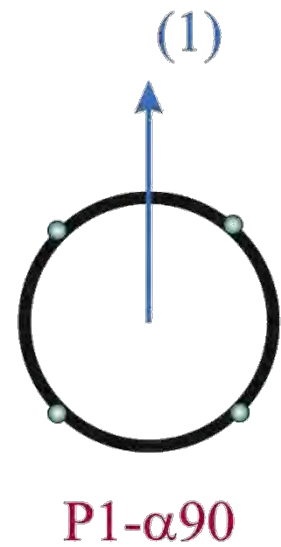
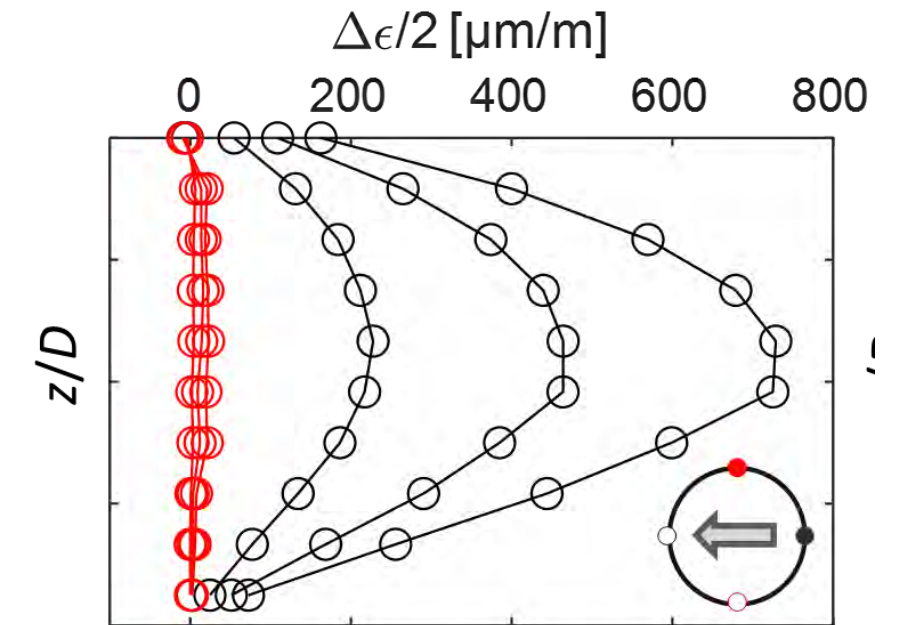
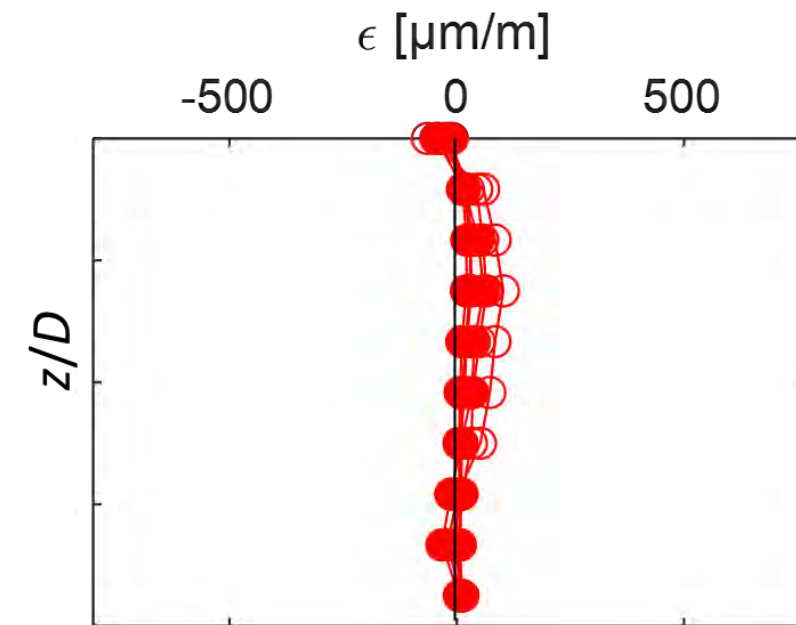
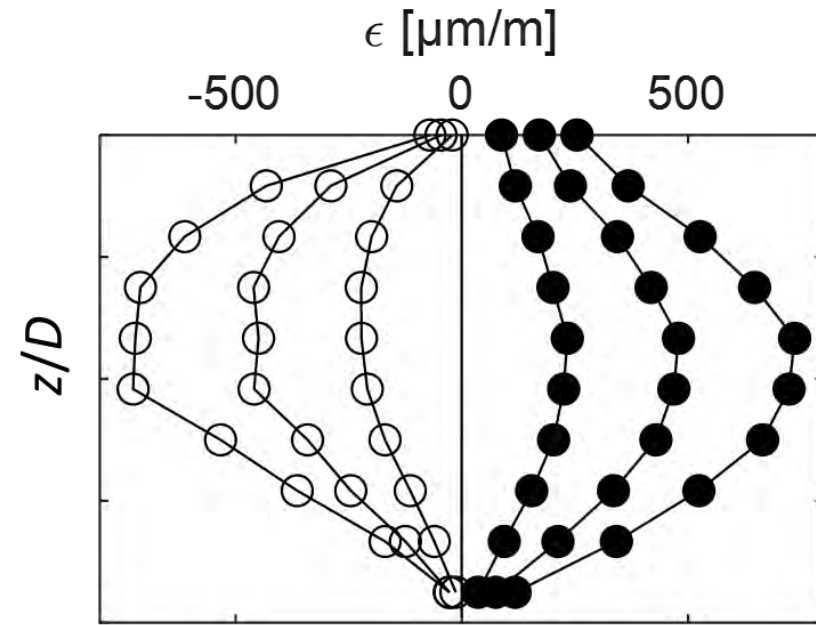
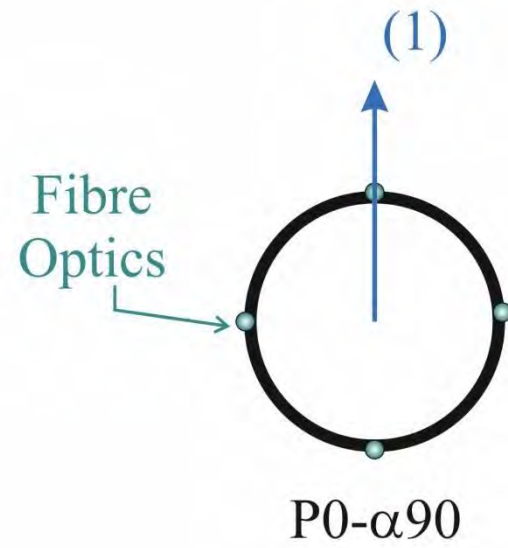

# Develop a new experimental set-up for multi-directional loading of anchors

Plan view of the container and tested locations

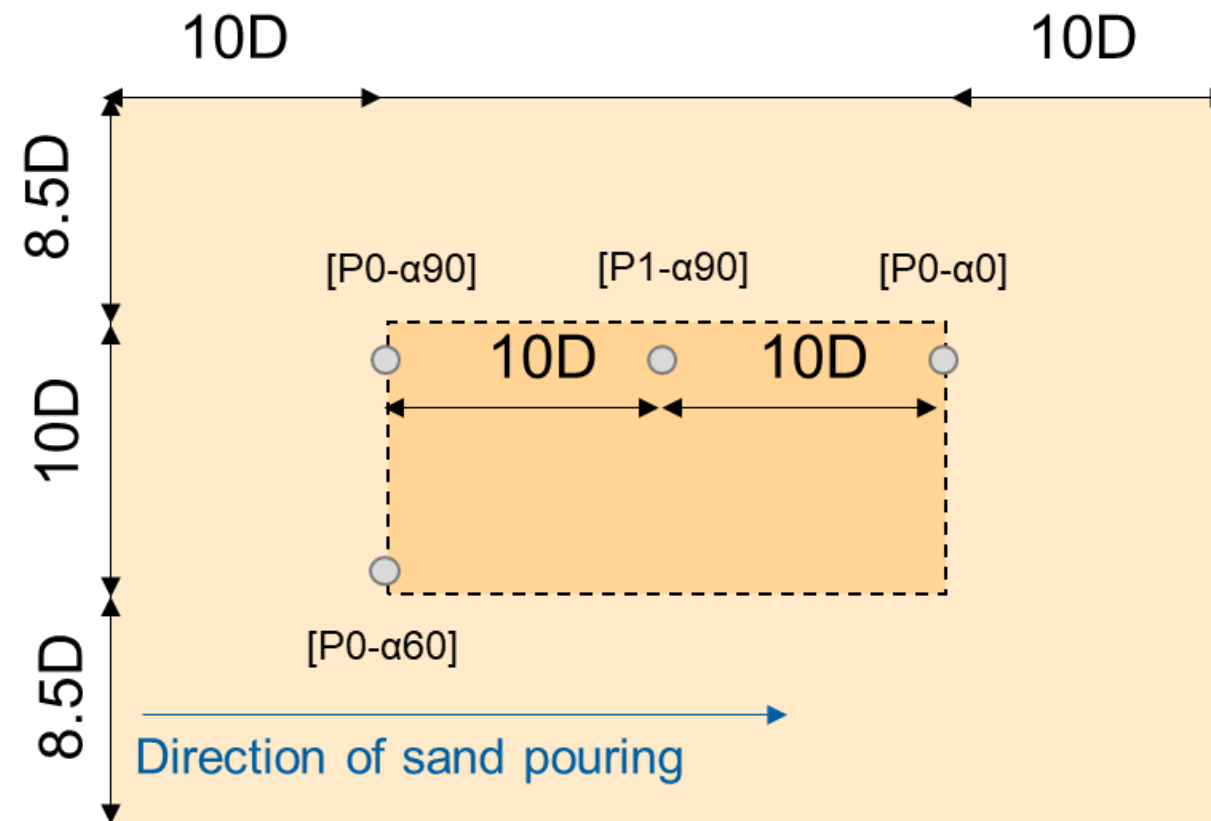

**Fontainebleau NE34 sand**

$C_u$	1.53
$d_{50}$ ( $\mu\text{m}$ )	210
$\rho_{d,\text{min}}$ ( $\text{g}/\text{cm}^3$ )	1.76
$\rho_{d,\text{max}}$ ( $\text{g}/\text{cm}^3$ )	1.71
$e_{\text{max}}$	0.753
$e_{\text{min}}$	0.549

Demonstration of sand pouring process



## 2. Understand key mechanisms driving pile response to multi-directional loading

### General objective

Increase knowledge on multi-directional cyclic loading effects on shared anchor piles for floating wind turbines through centrifuge modelling

### 5 main objectives corresponding to deliverables

1. Develop and Validate a **new experimental set-up** for multi-directional loading of anchors
2. Understand key mechanisms driving pile response to **multi-directional loading**
3. Expand conclusions to **multi-directional cyclic loading**
4. Compare with **numerical** analyses for validation and perspectives
5. Provide an **experimental database** for future work on shared anchor piles



## 2. Understand key mechanisms driving pile response to multi-directional loading

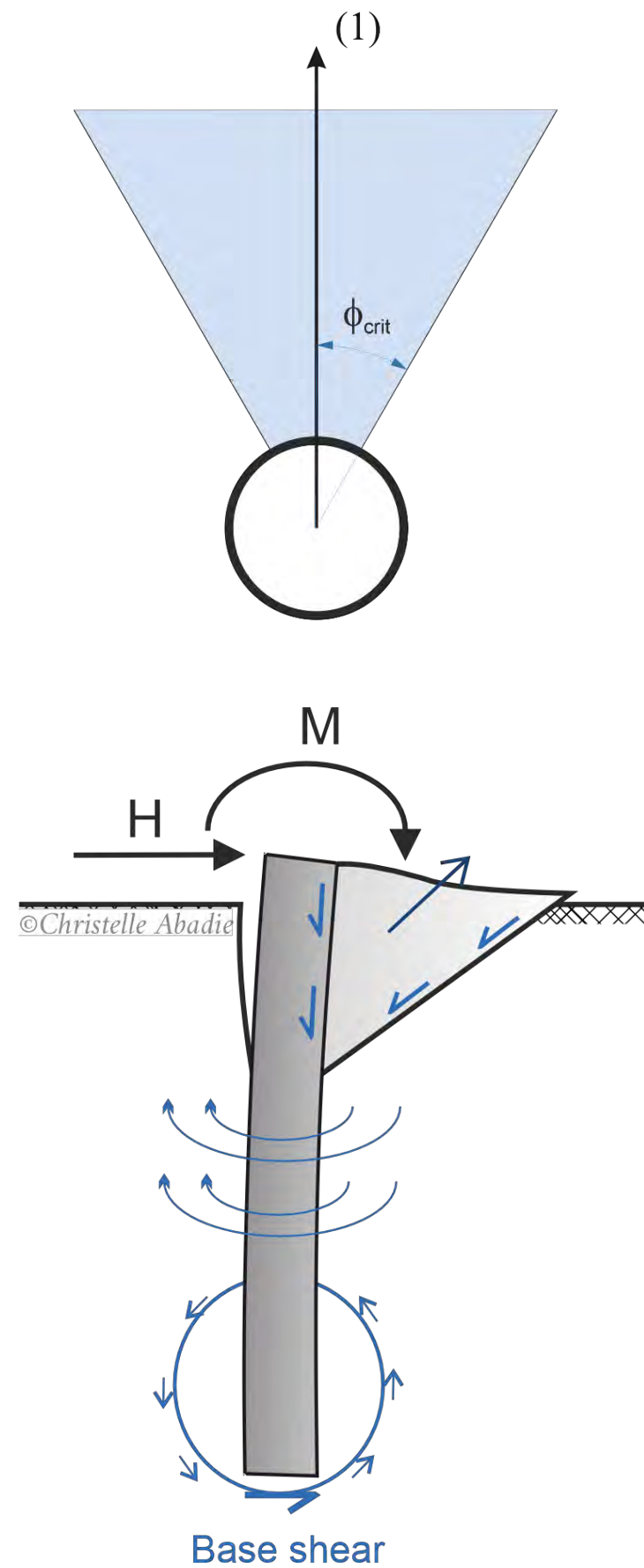

# 1. Understand key mechanisms driving pile response to multi-directional loading

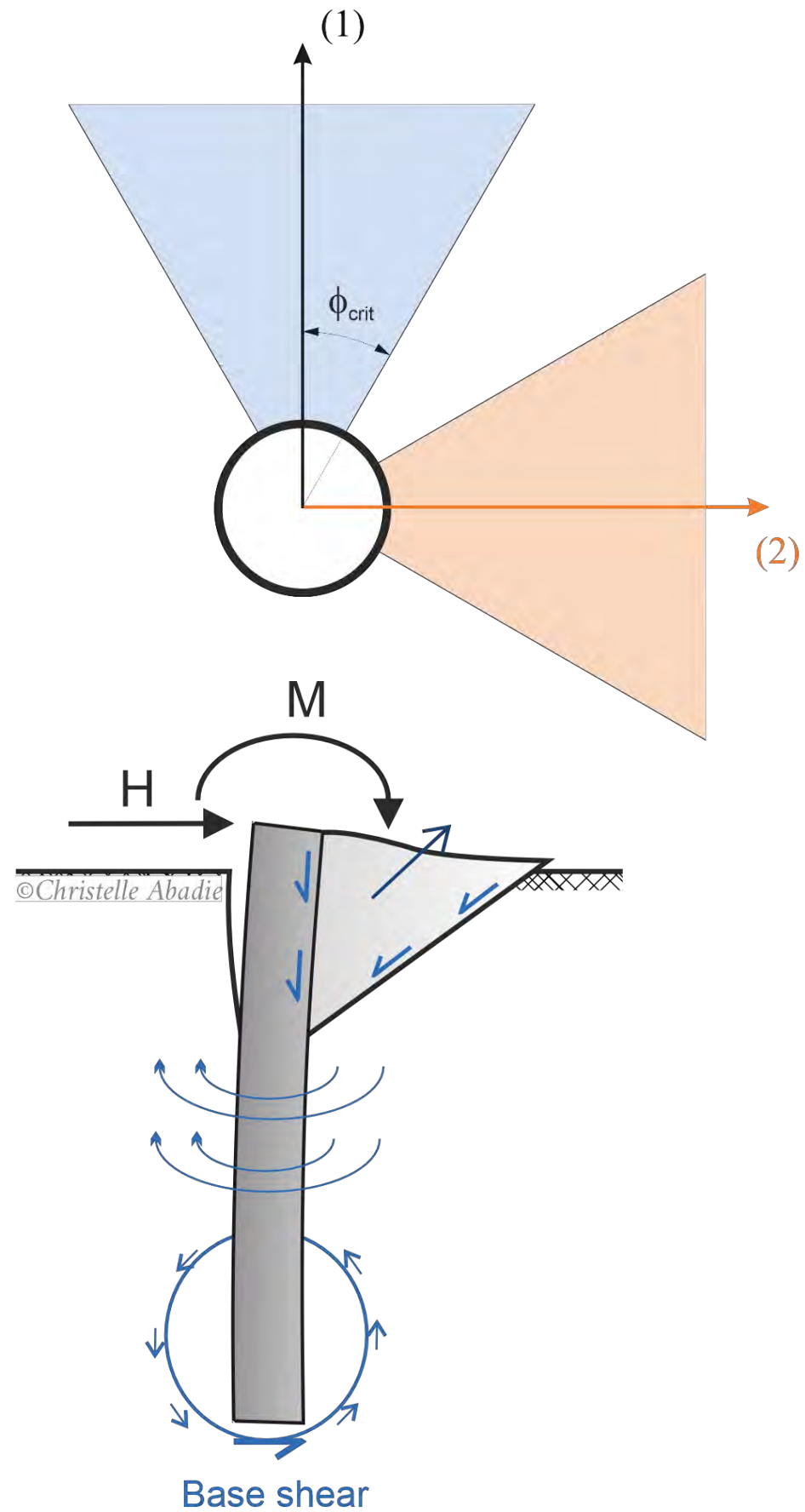

# 1. Understand key mechanisms driving pile response to multi-directional loading

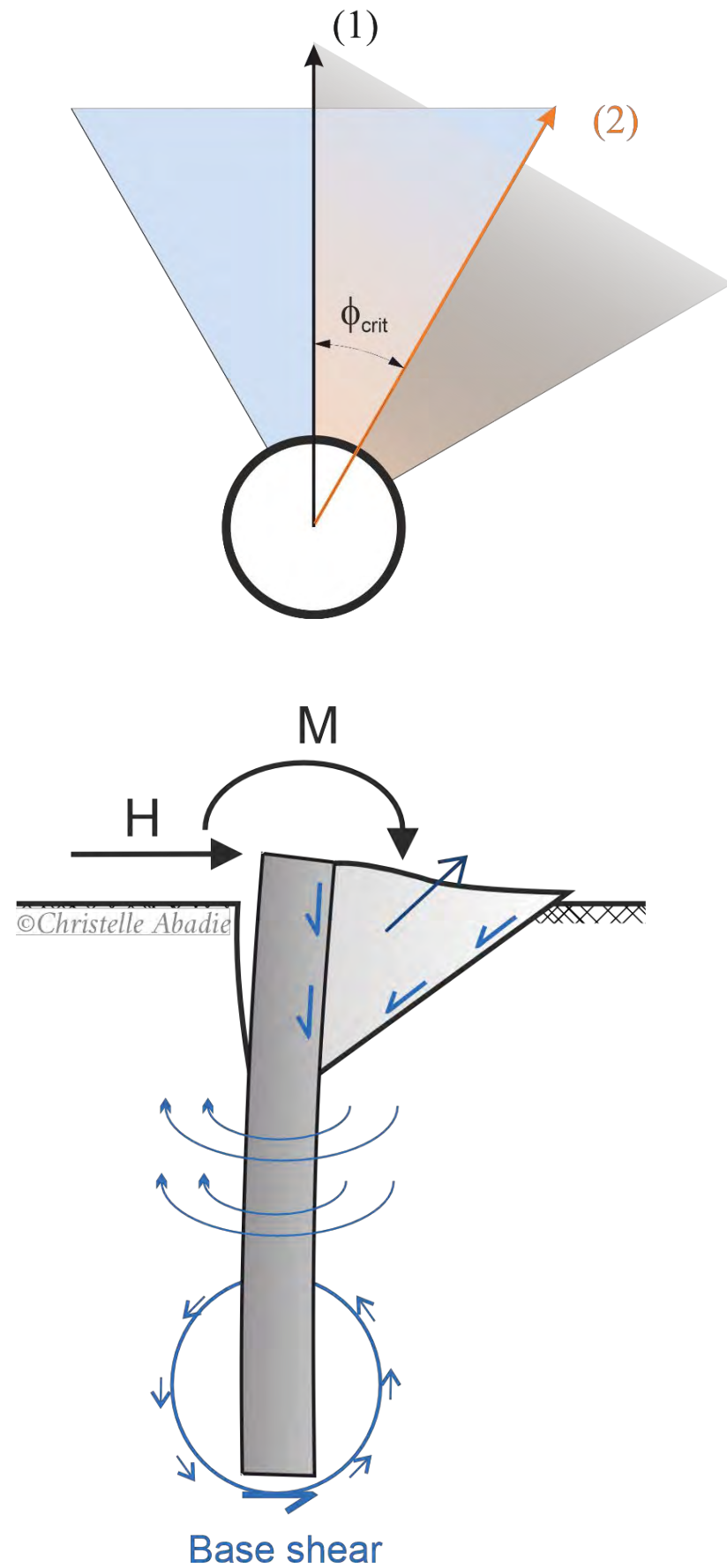

## 2. Understand key mechanisms driving pile response to multi-directional loading

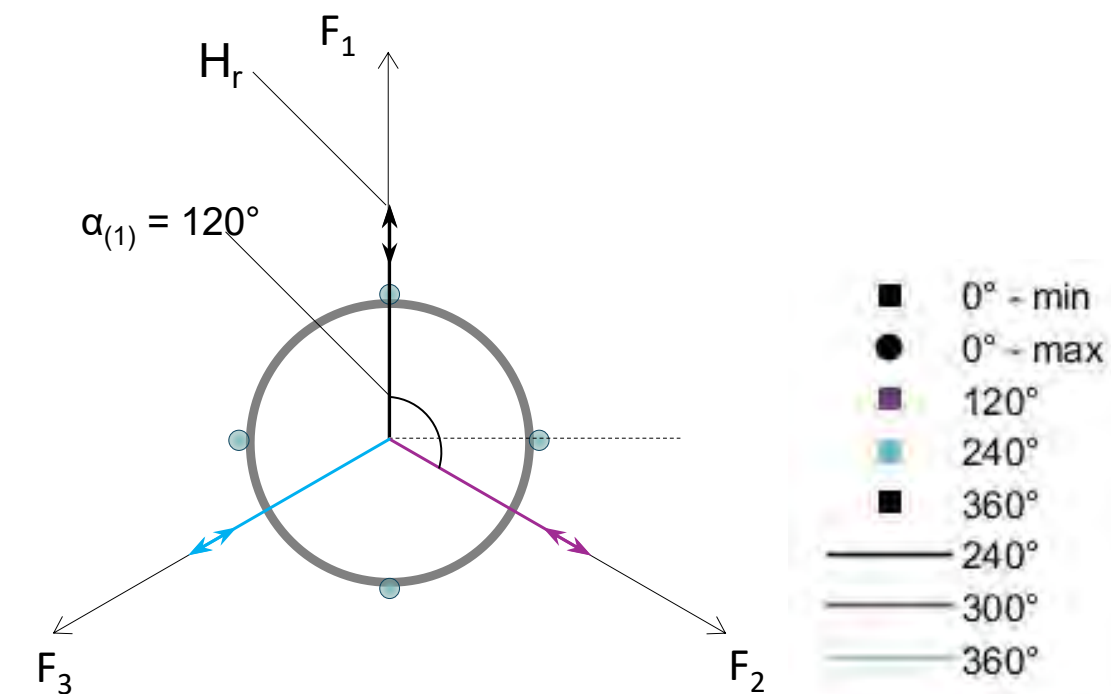
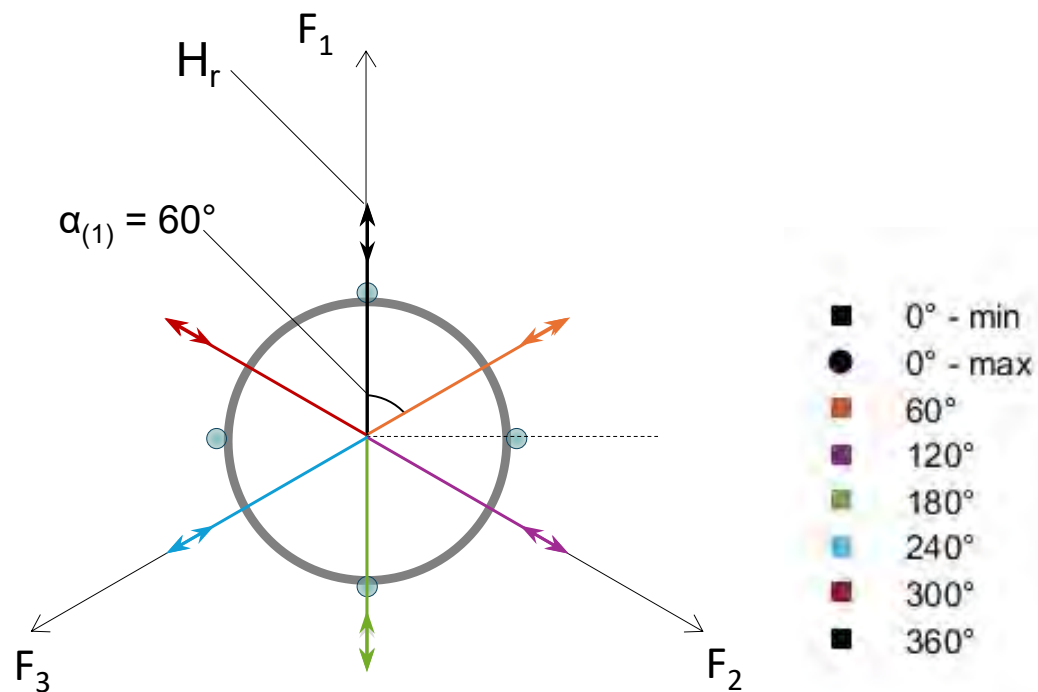
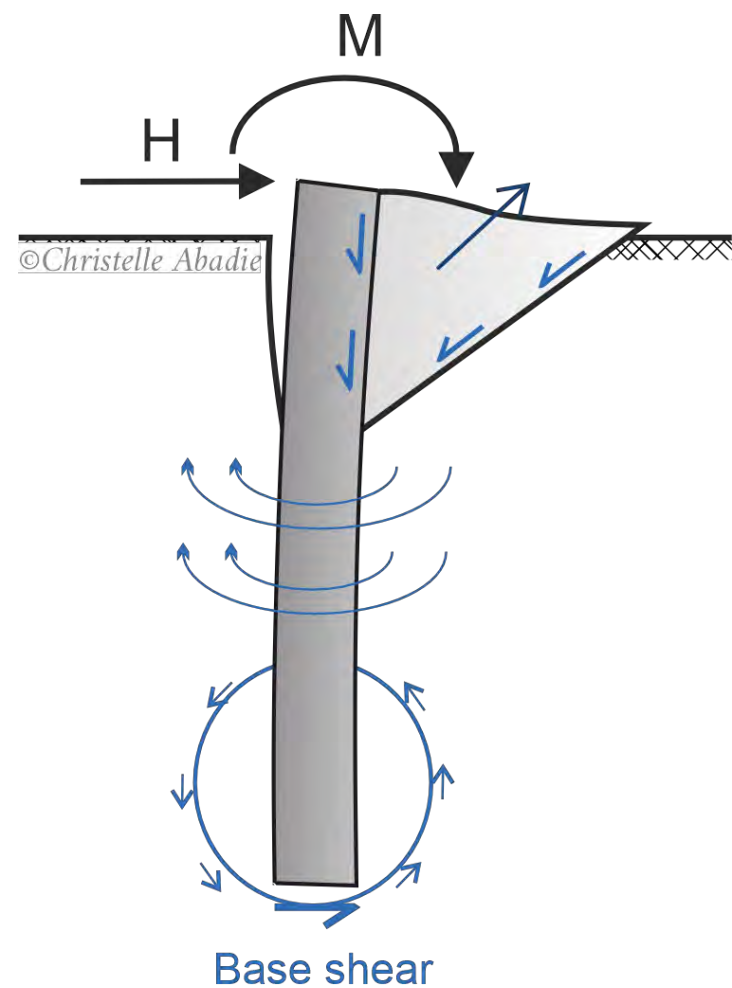
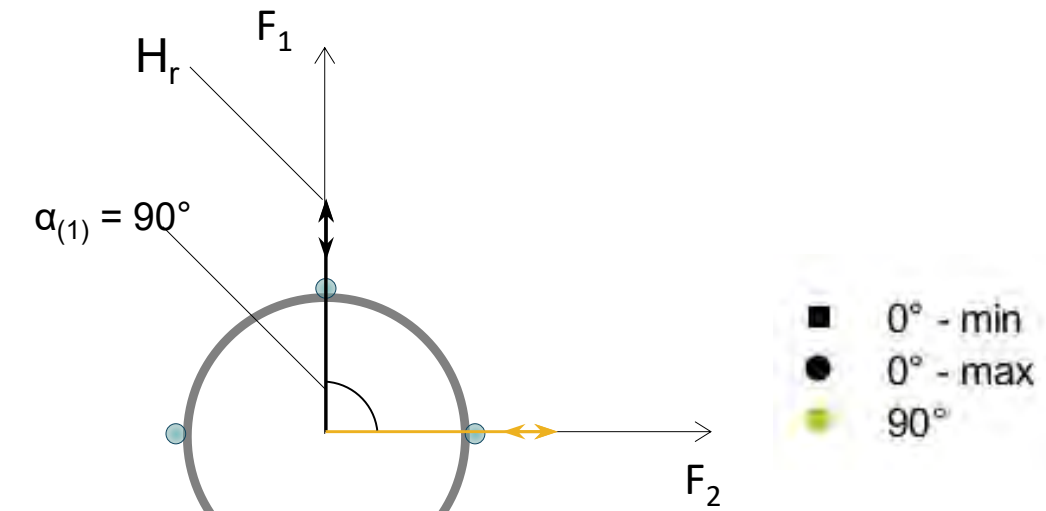
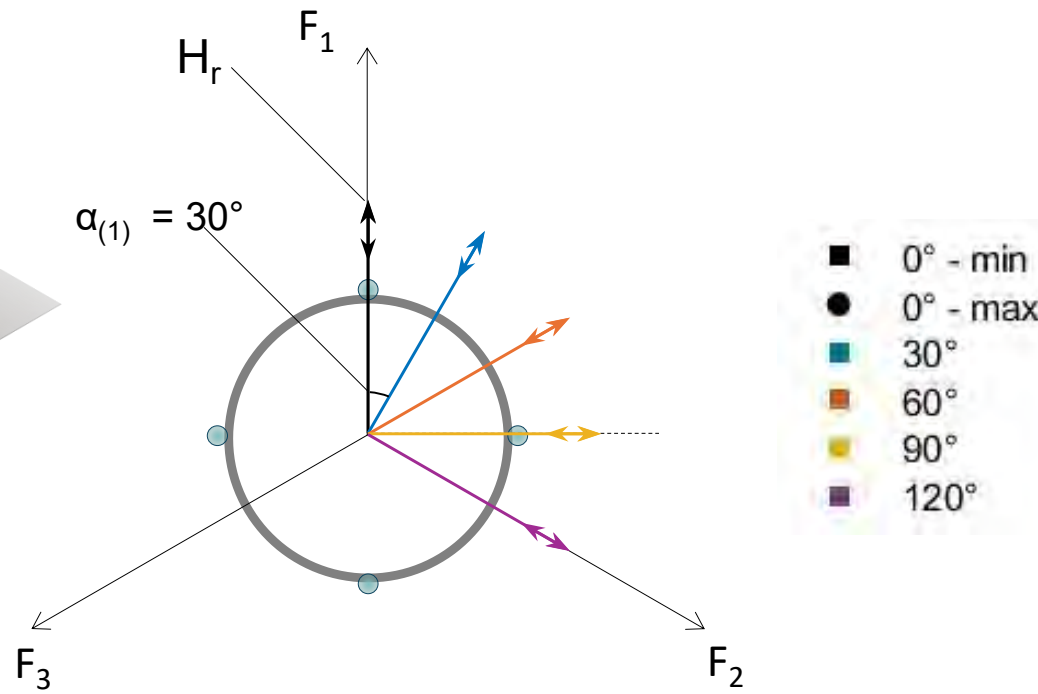
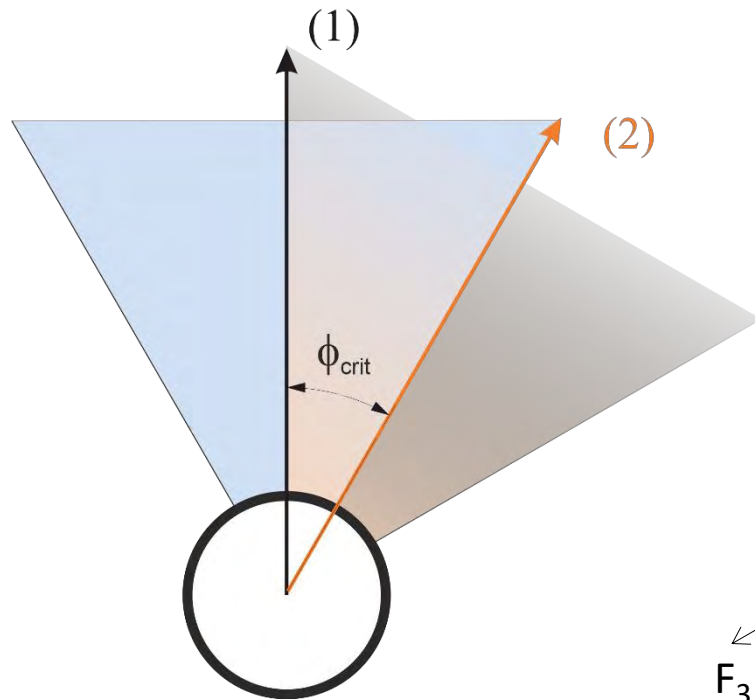

## 2. Understand key mechanisms driving pile response to multi-directional loading

- High irreversible displacement - high plastic deformation
- Non-colinearity of the load and displacement increment

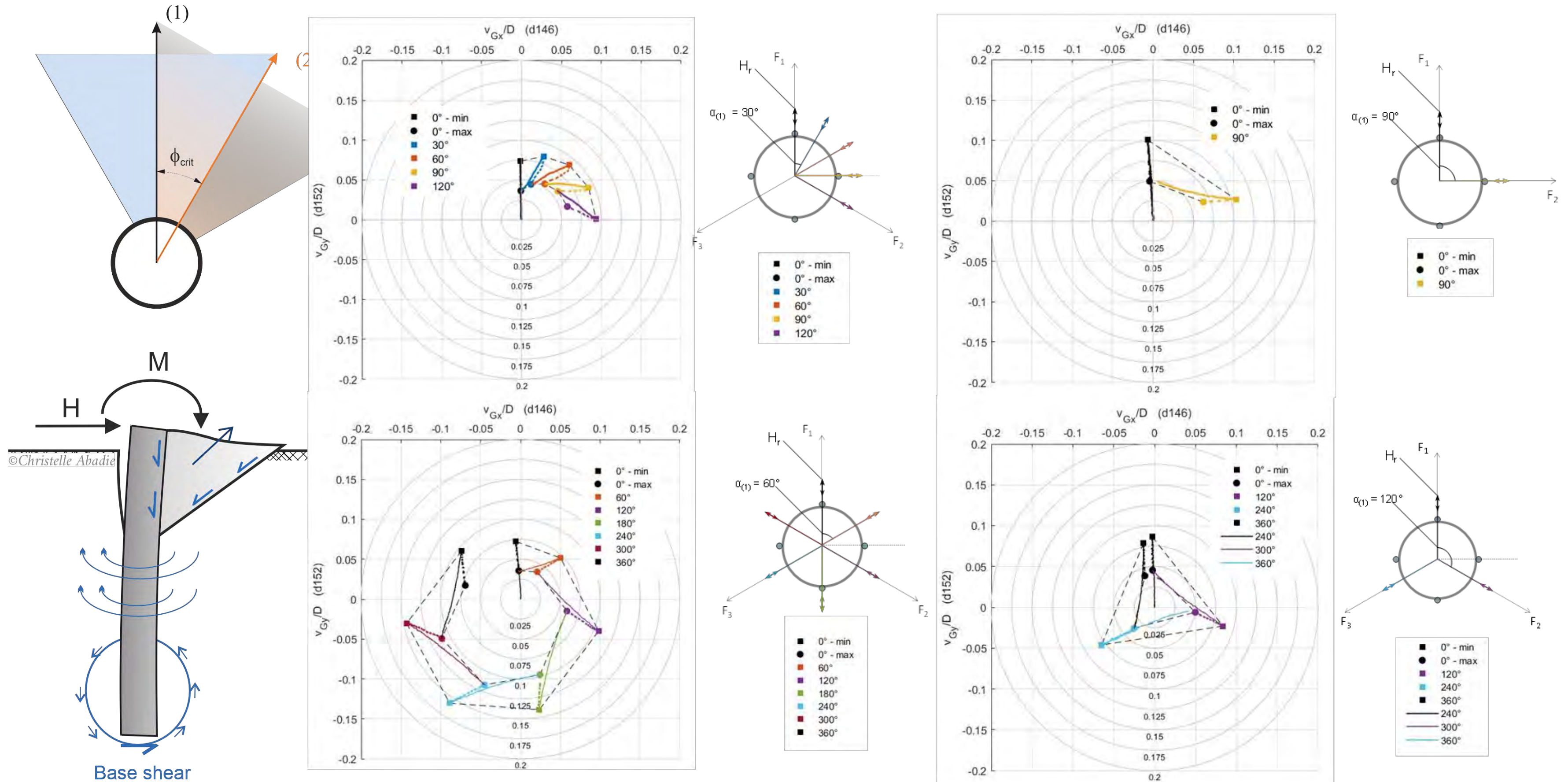

### 3. Expand conclusions to multi-directional cyclic loading

#### General objective

Increase knowledge on multi-directional cyclic loading effects on shared anchor piles for floating wind turbines through centrifuge modelling

#### 5 main objectives corresponding to deliverables

1. Develop and Validate a **new experimental set-up** for multi-directional loading of anchors
2. Understand key mechanisms driving pile response to **multi-directional loading**
3. Expand conclusions to **multi-directional cyclic loading**
4. Compare with **numerical** analyses for validation and perspectives
5. Provide an **experimental database** for future work on shared anchor piles



### 3. Expand conclusions to multi-directional cyclic loading

#### Test Programme:

- **Uni-directional Cyclic test:** single axis  $1008 \times \zeta_b = 0.2 \rightarrow 112 \times \zeta_b = 0.6 \rightarrow 10 \times \zeta_b = 1.0 \rightarrow 1 \times \zeta_b = 1.2$
- **Fan test:** same cyclic loading sequence, direction of the load varies in the shape of a fan, with an increment of  $15^\circ$  between each cycle, and an “opening” of the fan of  $\pm 45^\circ$
- **Cross test:** pile is pushed to target  $\zeta_b$ , cycles are applied in the perpendicular direction in a straight line, with an “opening” of  $\pm 45^\circ$
- **Circle test:** pile is pushed to target  $\zeta_b$ , cycles are applied in the perpendicular direction following an arch, with an “opening” of  $\pm 45^\circ$

$$1008 \times \zeta_b = 0.2 \rightarrow 112 \times \zeta_b = 0.6 \rightarrow 12 \times \zeta_b = 1.0 \rightarrow 1 \times \zeta_b = 1.2$$

#### Uni-directional cyclic test:

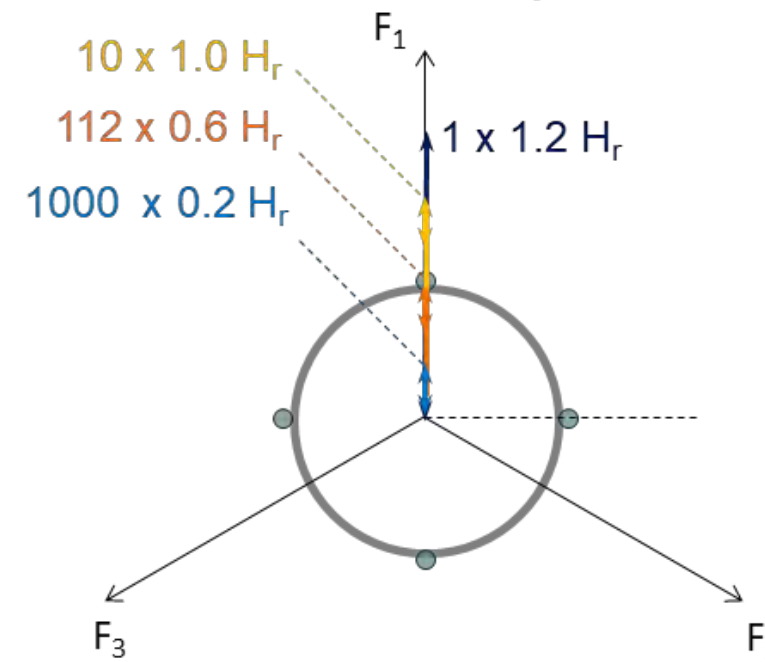

#### Fan test at $\pm 45^\circ$ , $\Delta\alpha = 15^\circ$

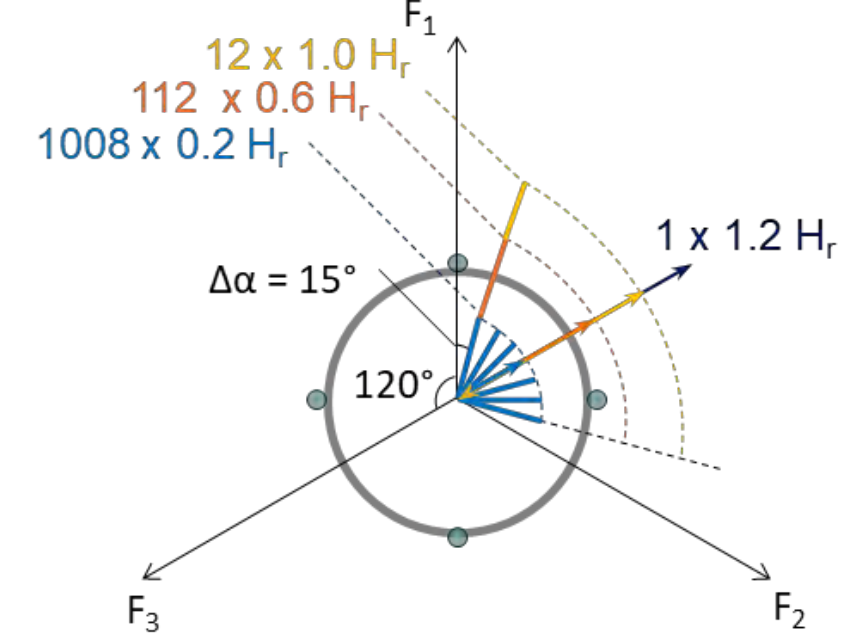

#### Cross test at $\pm 45^\circ$

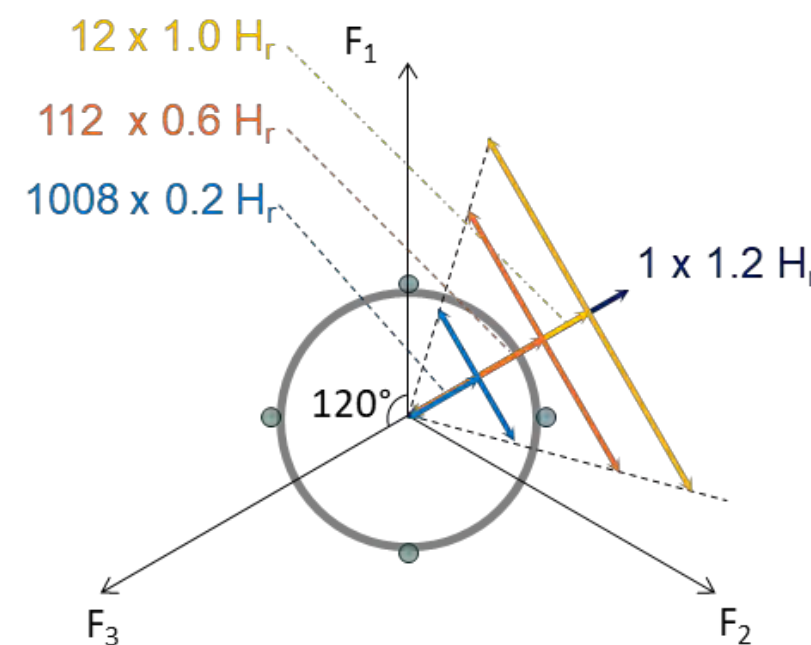

#### Circle test at $\pm 45^\circ$

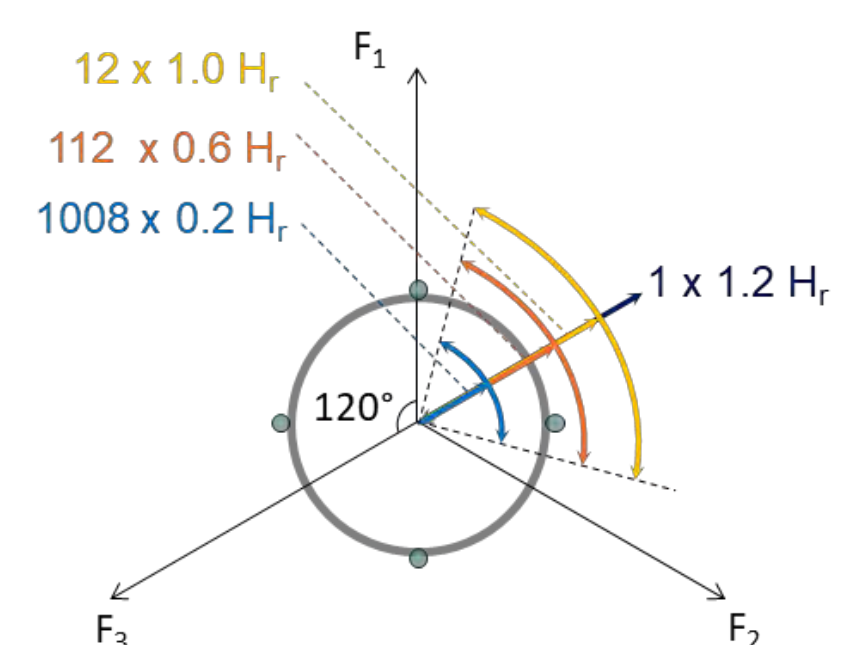

### 3. Expand conclusions to multi-directional cyclic loading

#### Test Programme:

- **Uni-directional Cyclic test:** single axis  $1008 \times \zeta_b = 0.2 \rightarrow 112 \times \zeta_b = 0.6 \rightarrow 10 \times \zeta_b = 1.0 \rightarrow 1 \times \zeta_b = 1.2$
- **Fan test:** same cyclic loading sequence, direction of the load varies in the shape of a fan, with an increment of  $15^\circ$  between each cycle, and an “opening” of the fan of  $\pm 45^\circ$
- **Cross test:** pile is pushed to target  $\zeta_b$ , cycles are applied in the perpendicular direction in a straight line, with an “opening” of  $\pm 45^\circ$
- **Circle test:** pile is pushed to target  $\zeta_b$ , cycles are applied in the perpendicular direction following an arch, with an “opening” of  $\pm 45^\circ$

#### Test Programme:

- **Uni-directional Cyclic test:** single axis  $1008 \times \zeta_b = 0.2 \rightarrow 112 \times \zeta_b = 0.6 \rightarrow 10 \times \zeta_b = 1.0 \rightarrow 1 \times \zeta_b = 1.2$
- **Fan test:** same cyclic loading sequence, direction of the load varies in the shape of a fan, with an increment of  $15^\circ$  between each cycle, and an “opening” of the fan of  $\pm 45^\circ$
- **Cross test:** pile is pushed to target  $\zeta_b$ , cycles are applied in the perpendicular direction in a straight line, with an “opening” of  $\pm 45^\circ$
- **Circle test:** pile is pushed to target  $\zeta_b$ , cycles are applied in the perpendicular direction following an arch, with an “opening” of  $\pm 45^\circ$

### 3. Expand conclusions to multi-directional cyclic loading

#### Test Programme:

- **Uni-directional Cyclic test:** single axis  $1008 \times \zeta_b = 0.2 \rightarrow 112 \times \zeta_b = 0.6 \rightarrow 10 \times \zeta_b = 1.0 \rightarrow 1 \times \zeta_b = 1.2$

#### Objective

Benchmark test: Needed for comparison with multi-directional cyclic loading test (and validation of numerical model)

$$1008 \times \zeta_b = 0.2 \rightarrow 112 \times \zeta_b = 0.6 \rightarrow 12 \times \zeta_b = 1.0 \rightarrow 1 \times \zeta_b = 1.2$$

#### Uni-directional cyclic test:

$10 \times 1.0 H_r$   
 $112 \times 0.6 H_r$   
 $1000 \times 0.2 H_r$

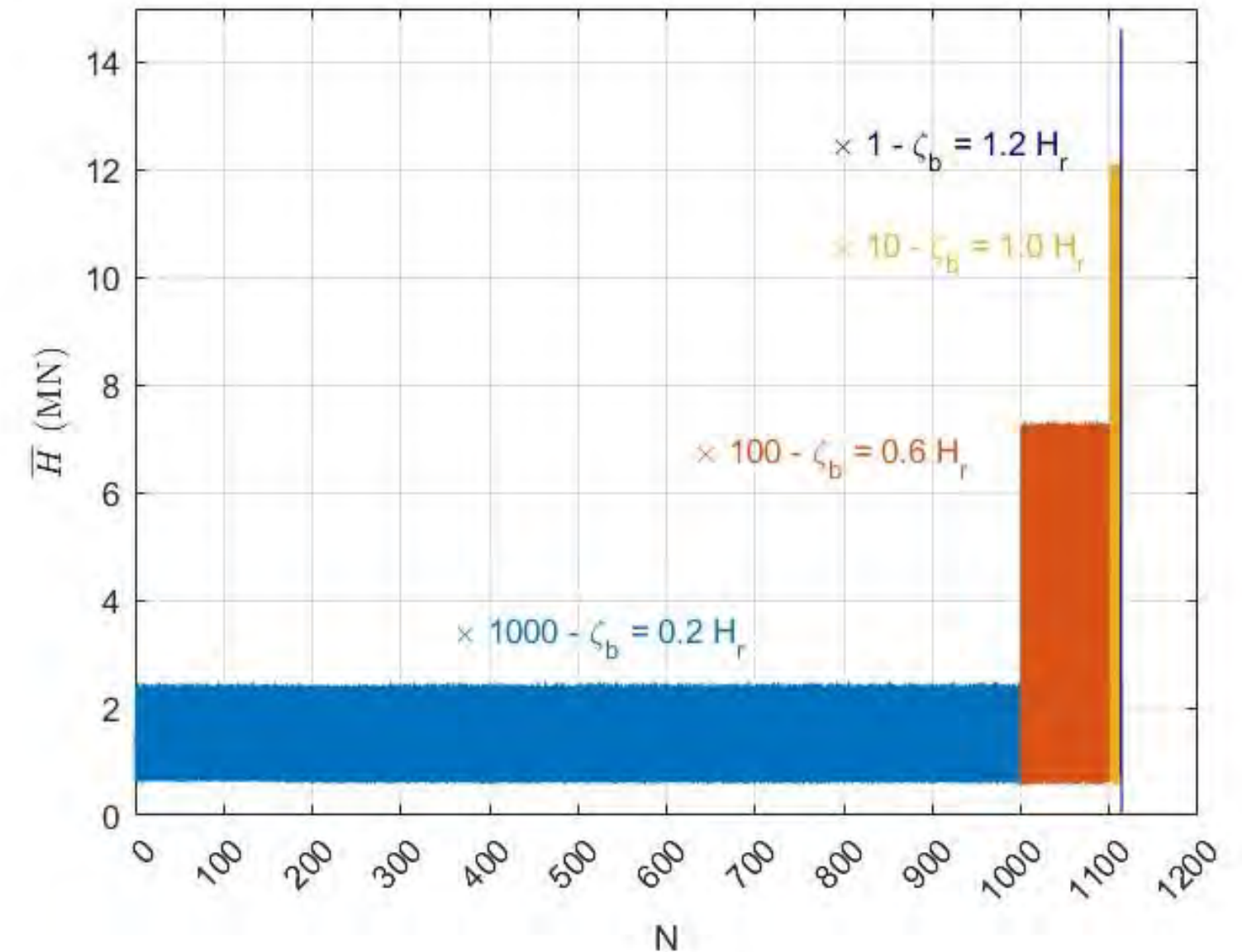

### 3. Expand conclusions to multi-directional cyclic loading

#### Test Programme:

- **Uni-directional Cyclic test:** single axis  $1008 \times \zeta_b = 0.2 \rightarrow 112 \times \zeta_b = 0.6 \rightarrow 10 \times \zeta_b = 1.0 \rightarrow 1 \times \zeta_b = 1.2$

#### Objective

Benchmark test: Needed for comparison with multi-directional cyclic loading test (and validation of numerical model)

$$1008 \times \zeta_b = 0.2 \rightarrow 112 \times \zeta_b = 0.6 \rightarrow 12 \times \zeta_b = 1.0 \rightarrow 1 \times \zeta_b = 1.2$$

#### Uni-directional cyclic test:

$10 \times 1.0 H_r$   
 $112 \times 0.6 H_r$   
 $1000 \times 0.2 H_r$   
 $1 \times 1.2 H_r$

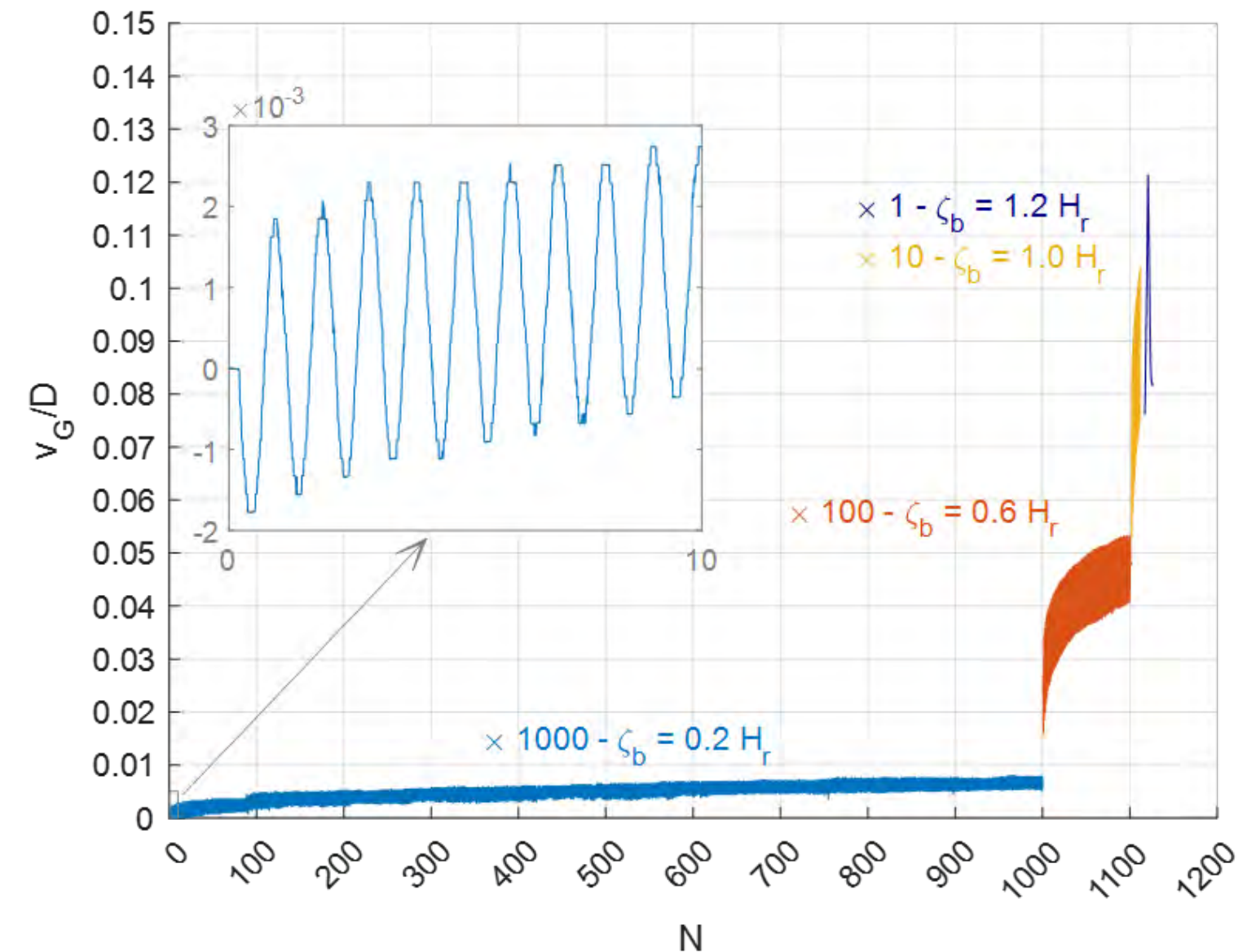

### 3. Expand conclusions to multi-directional cyclic loading

#### Test Programme:

- **Uni-directional Cyclic test:** single axis  $1008 \times \zeta_b = 0.2 \rightarrow 112 \times \zeta_b = 0.6 \rightarrow 10 \times \zeta_b = 1.0 \rightarrow 1 \times \zeta_b = 1.2$
- **Fan test:** same cyclic loading sequence, direction of the load varies in the shape of a fan, with an increment of  $15^\circ$  between each cycle, and an “opening” of the fan of  $\pm 45^\circ$
- **Cross test:** pile is pushed to target  $\zeta_b$ , cycles are applied in the perpendicular direction in a straight line, with an “opening” of  $\pm 45^\circ$
- **Circle test:** pile is pushed to target  $\zeta_b$ , cycles are applied in the perpendicular direction following an arch, with an “opening” of  $\pm 45^\circ$

$$1008 \times \zeta_b = 0.2 \rightarrow 112 \times \zeta_b = 0.6 \rightarrow 12 \times \zeta_b = 1.0 \rightarrow 1 \times \zeta_b = 1.2$$

#### Uni-directional cyclic test:

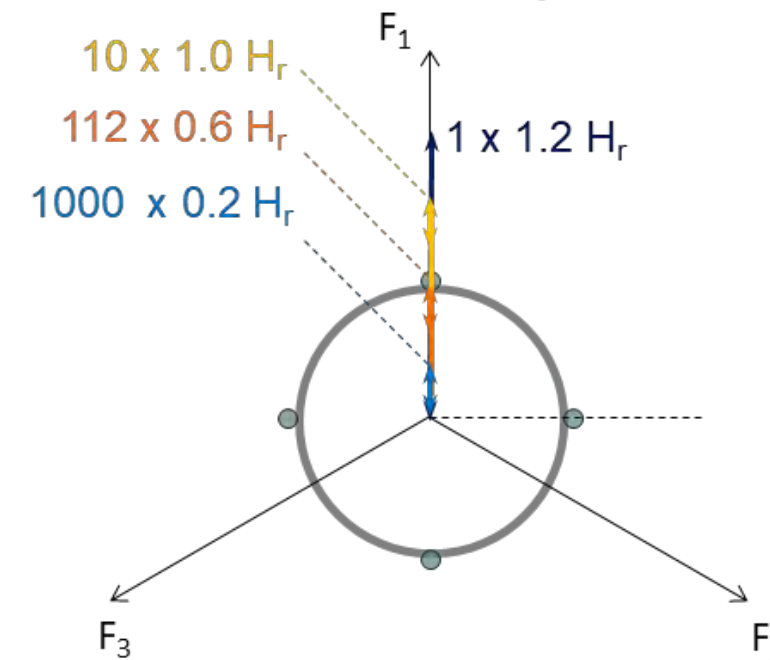

#### Fan test at $\pm 45^\circ$ , $\Delta\alpha = 15^\circ$

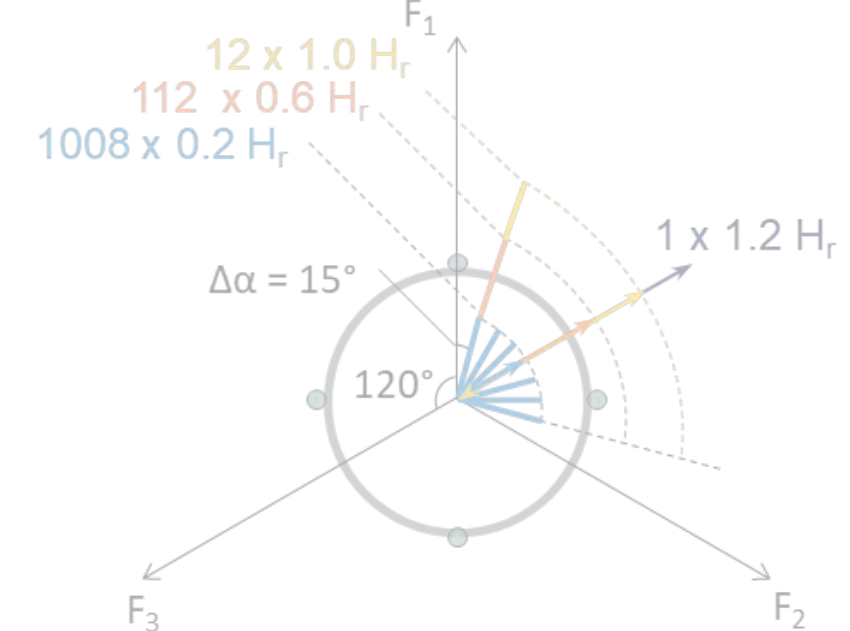

#### Cross test at $\pm 45^\circ$

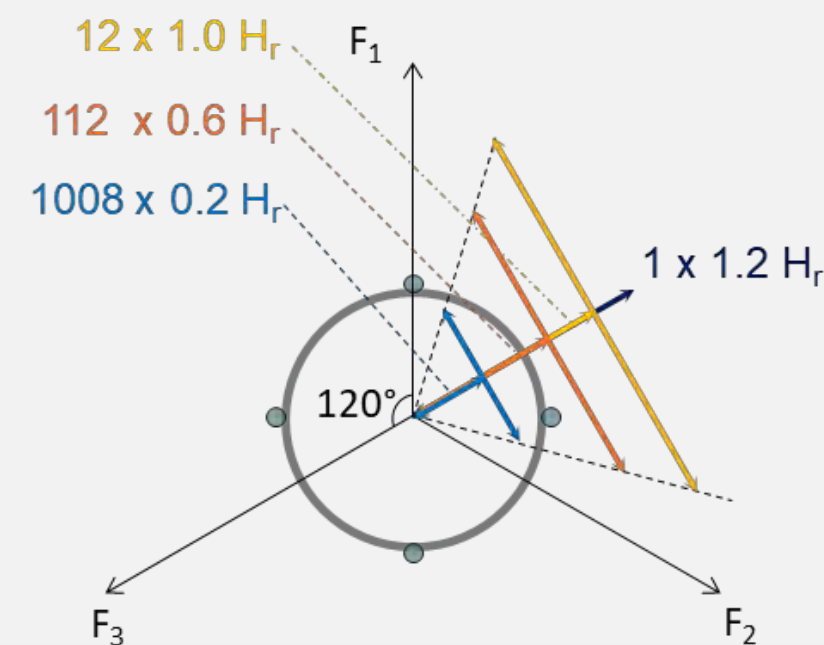

#### Circle test at $\pm 45^\circ$

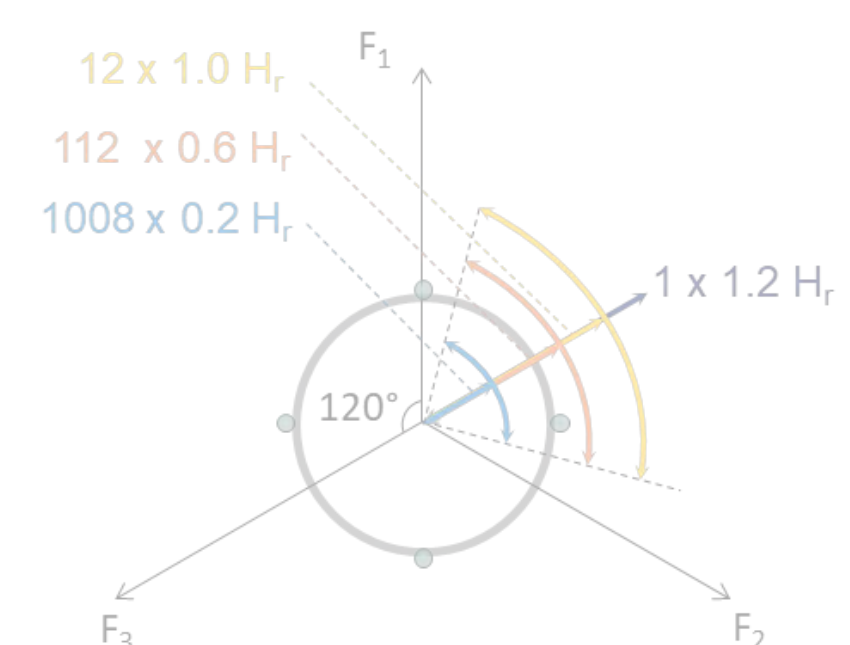

### 3. Expand conclusions to multi-directional cyclic loading

- **Cross test:** pile is pushed to target  $\zeta_b$ , cycles are applied in the perpendicular direction in a straight line, with an “opening” of  $\pm 45^\circ$

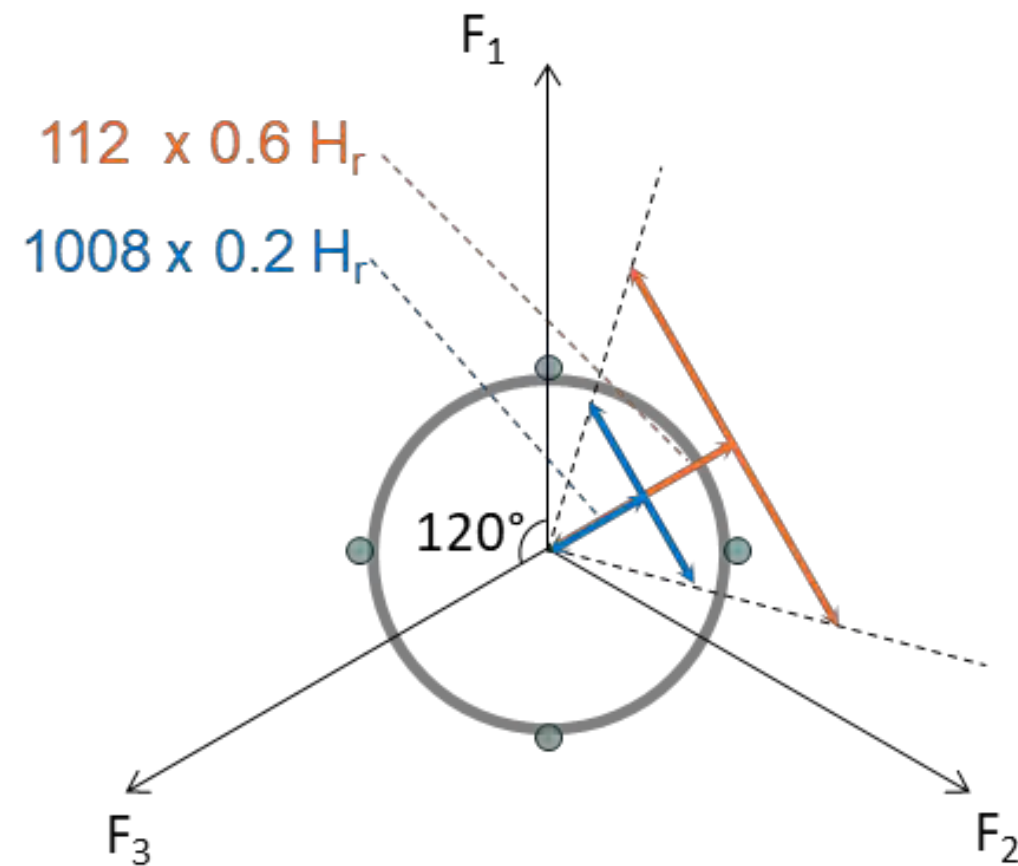

#### Objective

Coupling between principal directions: Do we accumulate in the « principal » direction when cycling perpendicularly?

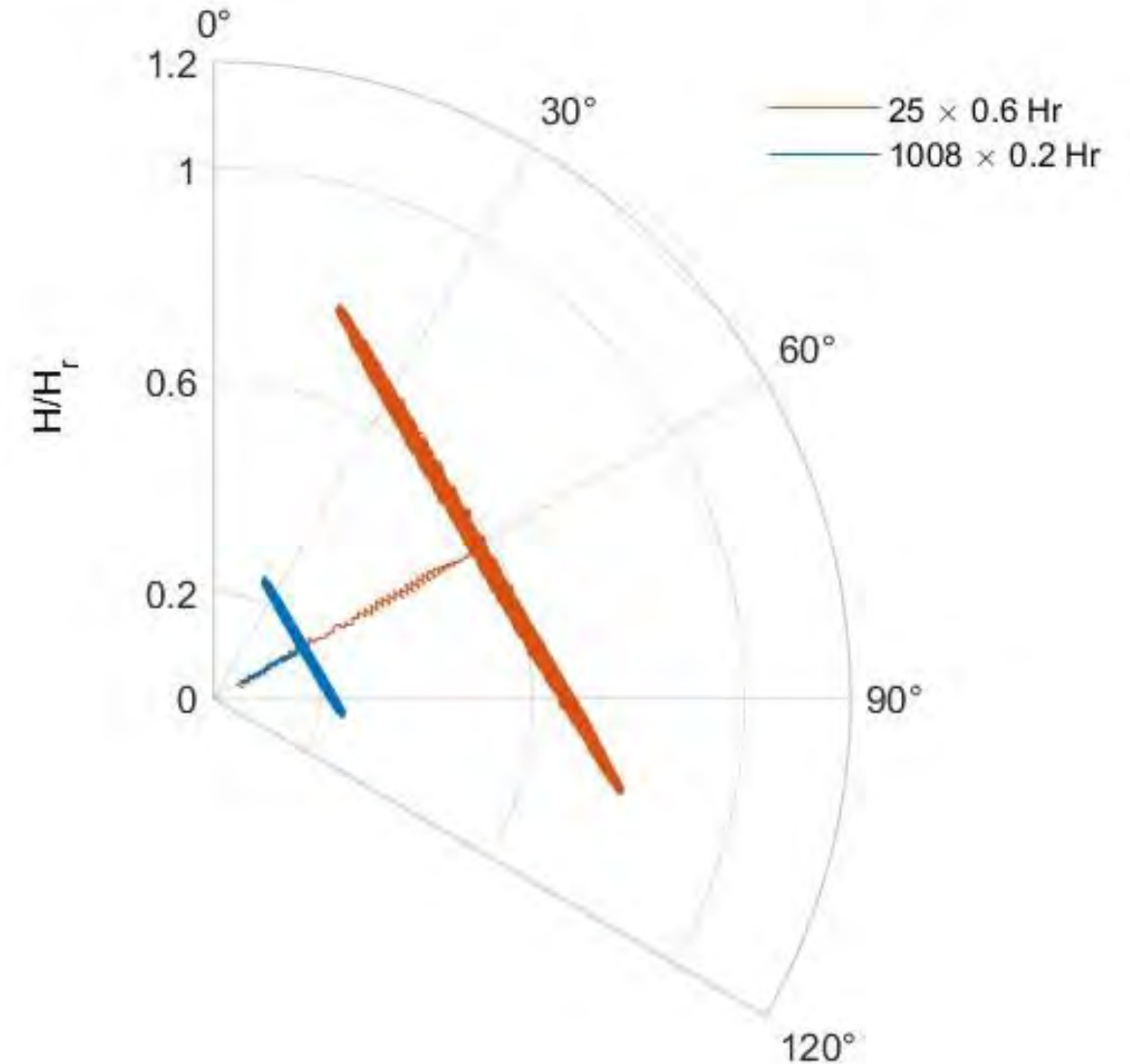

### 3. Expand conclusions to multi-directional cyclic loading

- **Cross test:** pile is pushed to target  $\zeta_b$ , cycles are applied in the perpendicular direction in a straight line, with an “opening” of +/- 45°

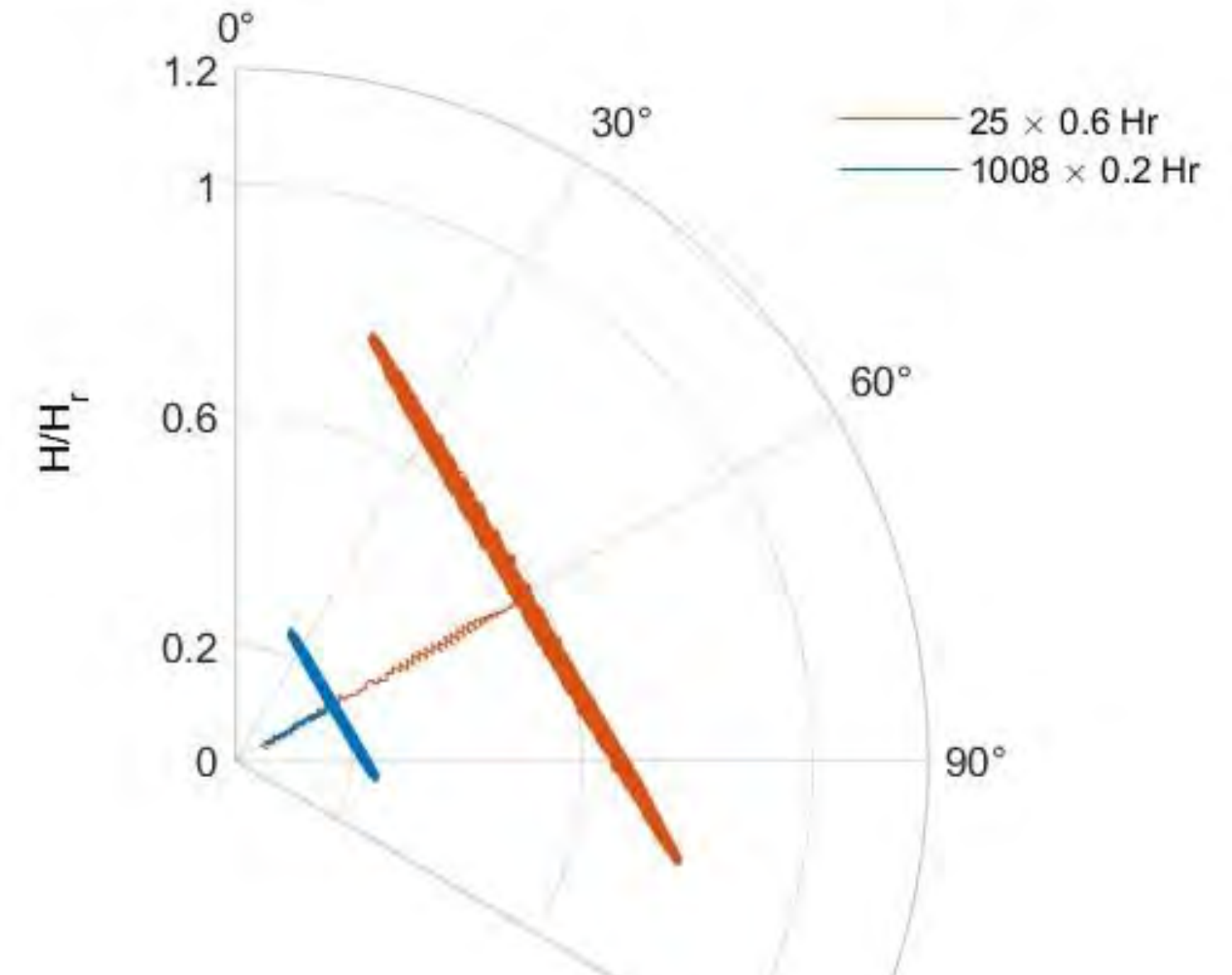
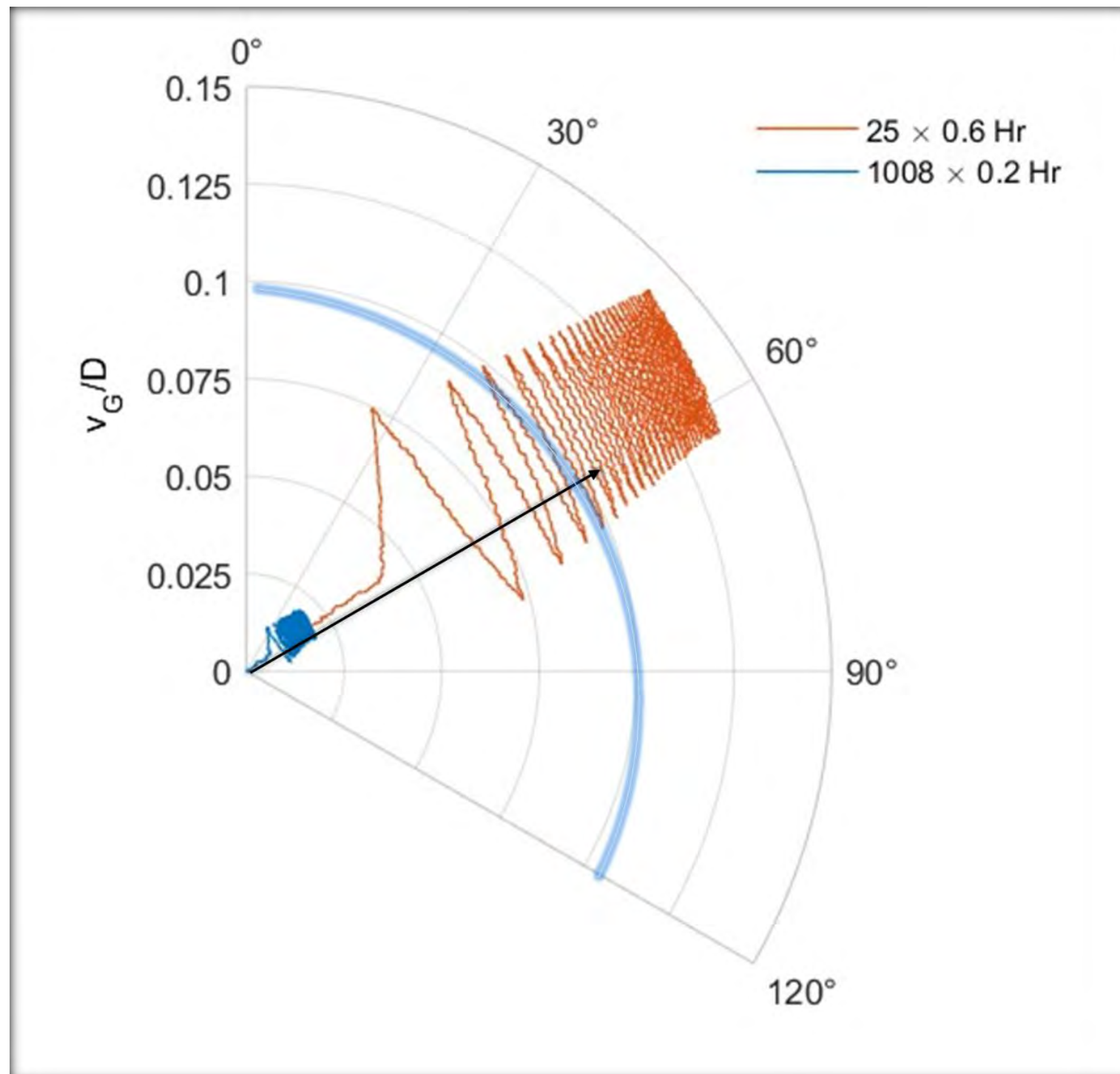

#### Conclusion

Accumulation of displacement in principal direction:  
can be significant for large loads

## 4. Compare with numerical analyses for validation and perspectives

### General objective

Increase knowledge on multi-directional cyclic loading effects on shared anchor piles for floating wind turbines through centrifuge modelling

### 5 main objectives corresponding to deliverables

1. Develop and Validate a **new experimental set-up** for multi-directional loading of anchors
2. Understand key mechanisms driving pile response to **multi-directional loading**
3. Expand conclusions to **multi-directional cyclic loading**
4. Compare with **numerical analyses** for validation and perspectives
5. Provide an **experimental database** for future work on shared anchor piles



## 4. Compare with numerical analyses for validation and perspectives

Aligned Wind / Waves / Currents, turbine parked :  
 $H_s = 11\text{m}$ ,  $T_p = 13\text{s}$ ,  $U_w = 40\text{ m/s}$ ,  $U_c = 1\text{ m/s}$

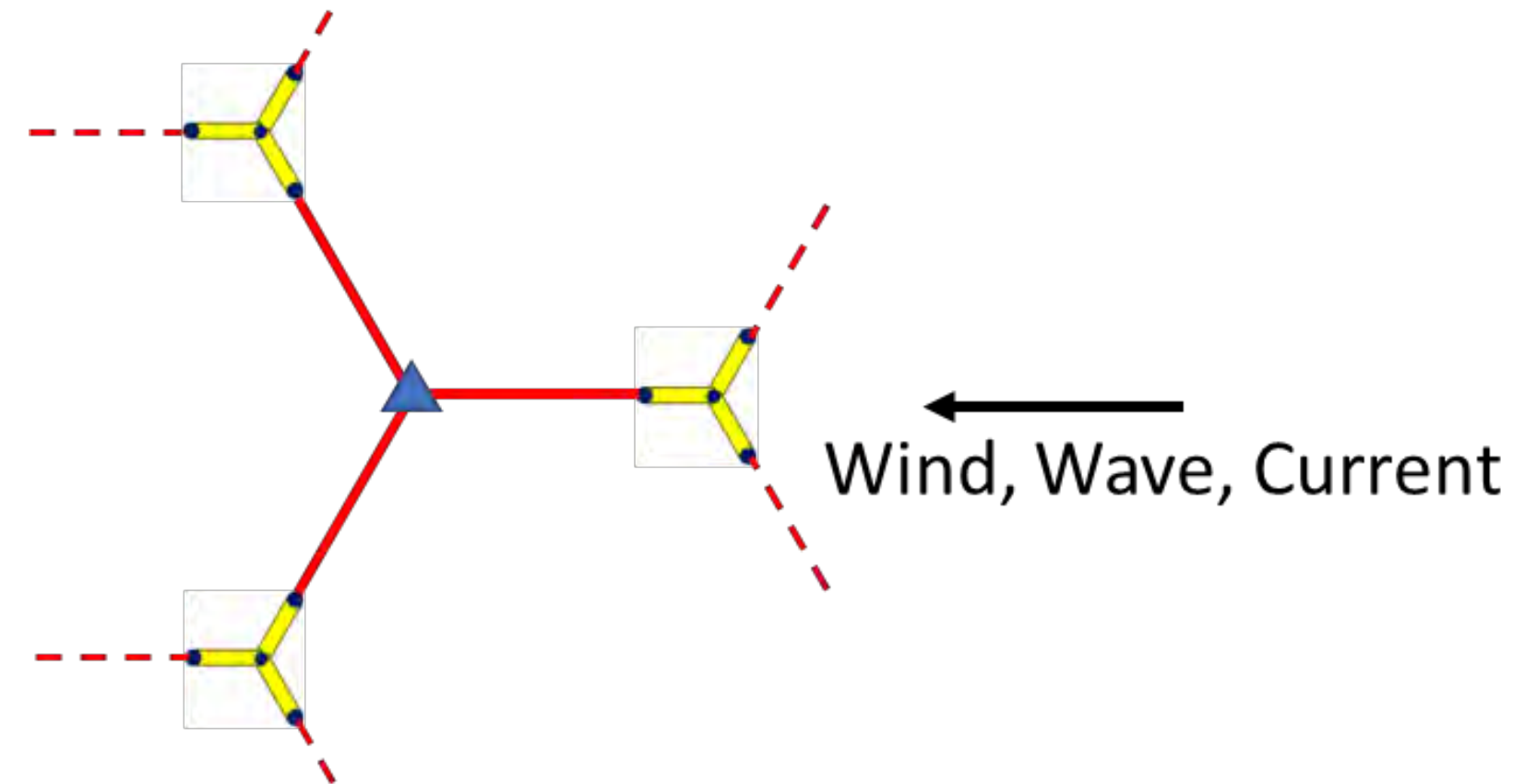
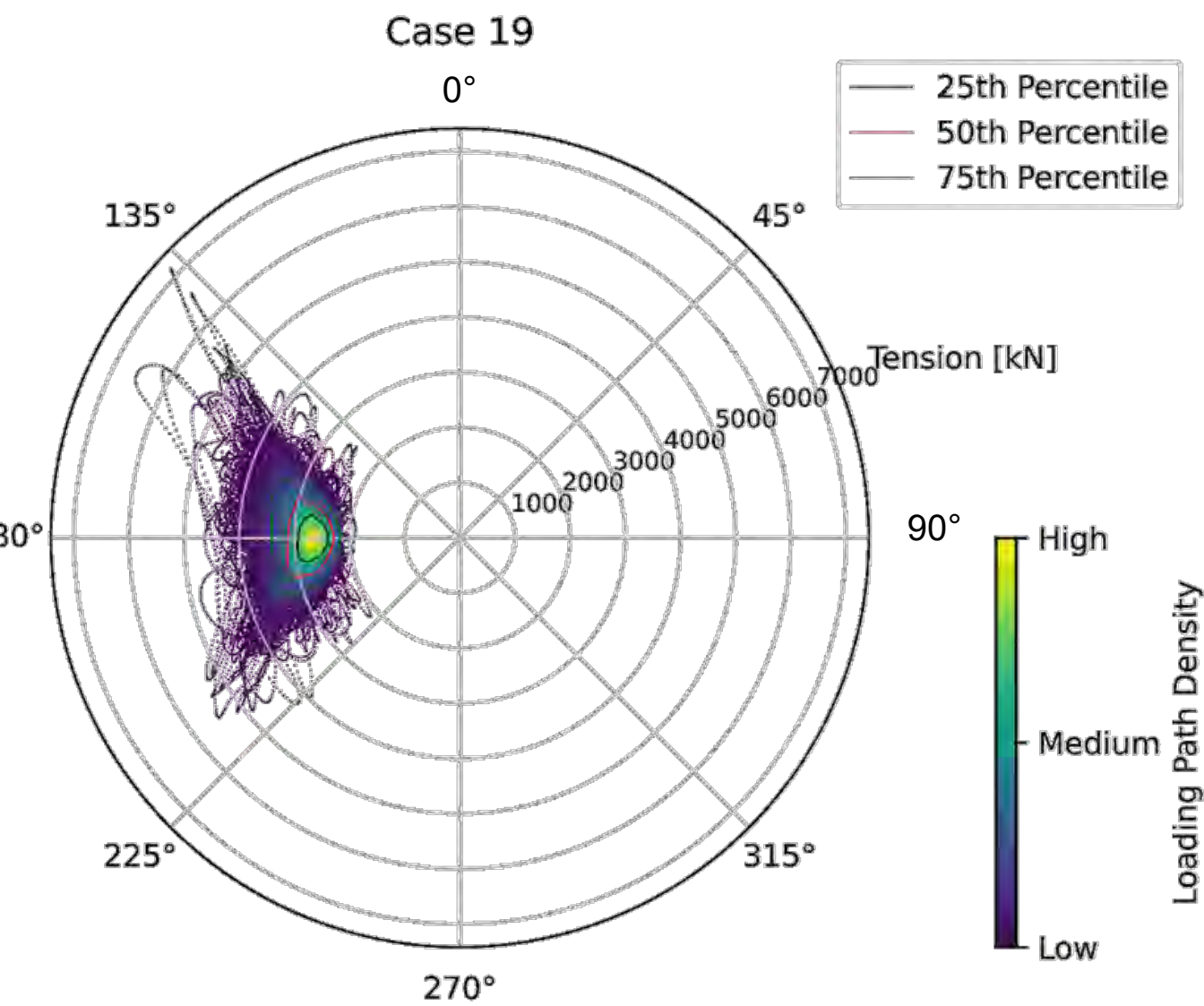

## 4. Compare with numerical analyses for validation and perspectives

Aligned Wind / Waves / Currents, turbine parked :  
 $H_s = 11\text{m}$ ,  $T_p = 13\text{s}$ ,  $U_w = 40\text{ m/s}$ ,  $U_c = 1\text{ m/s}$

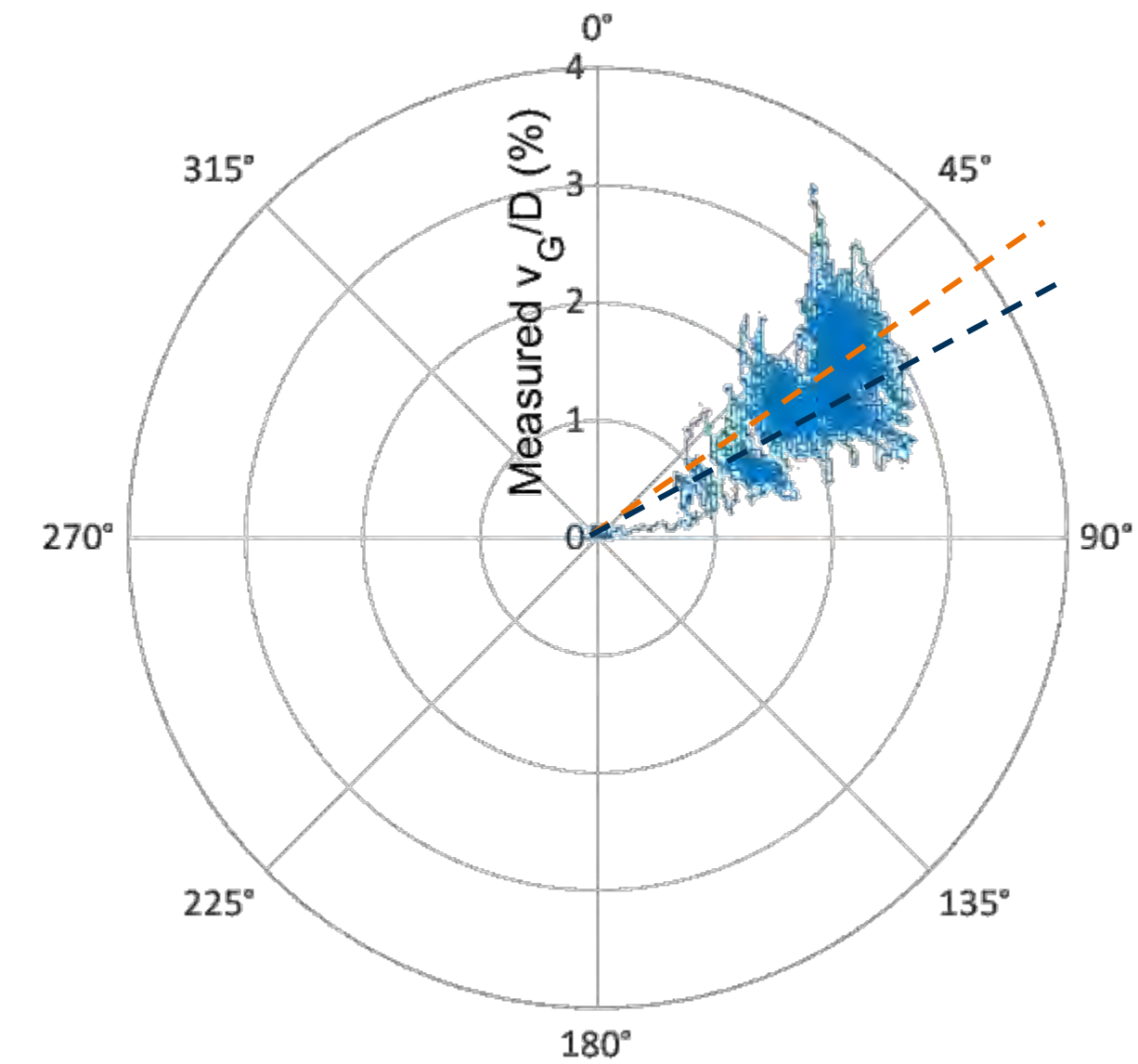
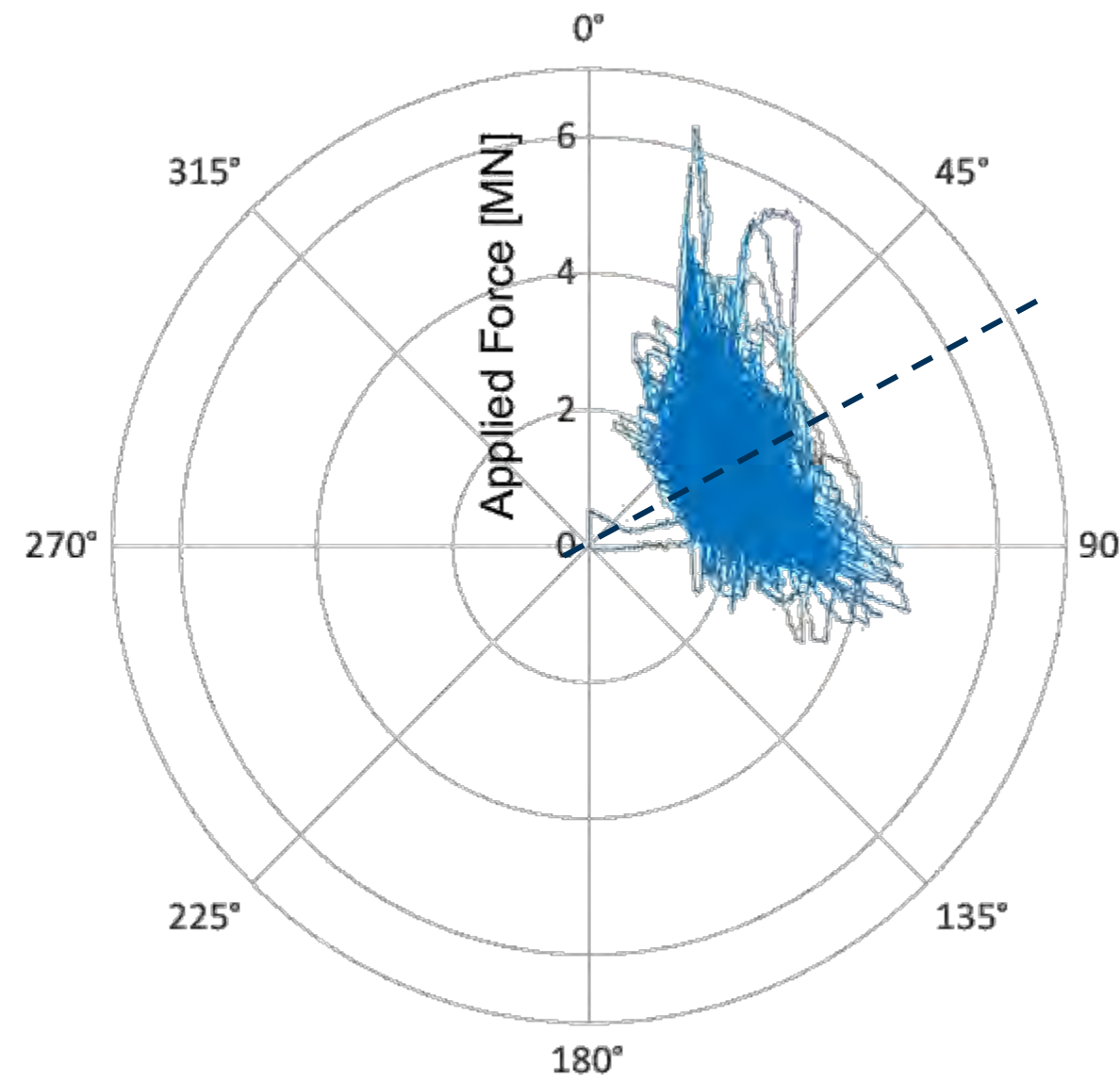
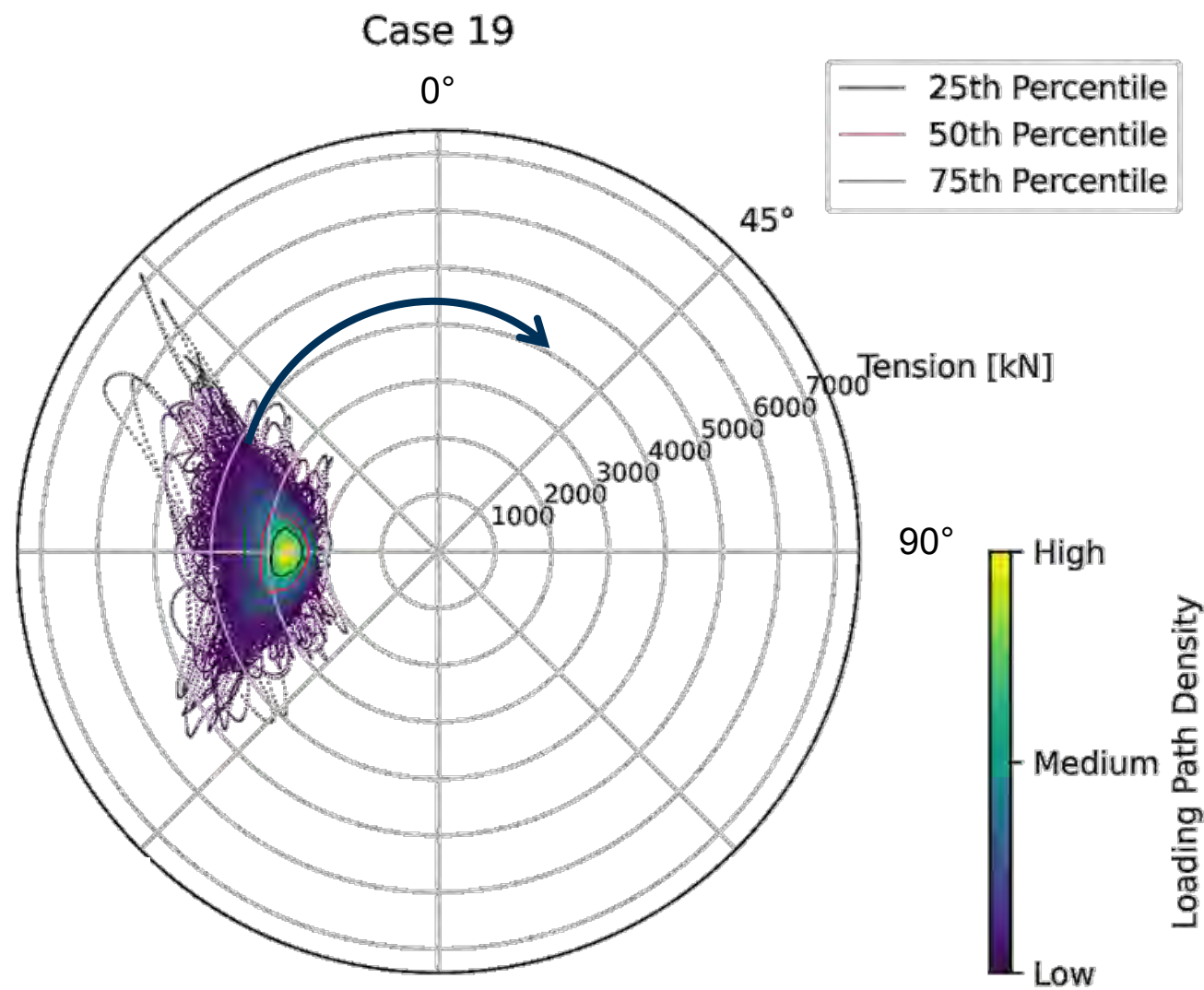

## 4. Compare with numerical analyses for validation and perspectives

- Promising first comparison; the two models follow similar trends (direction) during the storm event
- The numerical model accumulates more permanent displacement (in this specific instance)
- Further comparison on other tests will help to understand how to improve numerical modelling

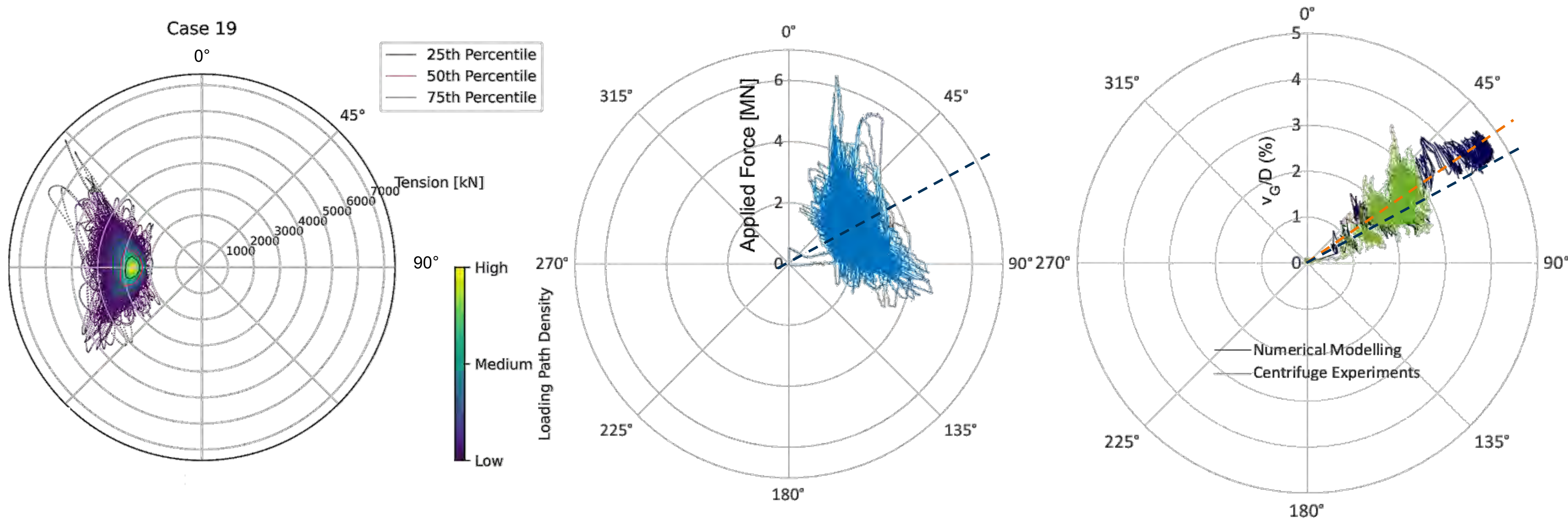

## General objective

Increase knowledge on multi-directional cyclic loading effects on shared anchor piles for floating wind turbines through centrifuge modelling

## 5 main objectives corresponding to deliverables

1. Develop and Validate a **new experimental set-up** for multi-directional loading of anchors
2. Understand key mechanisms driving pile response to **multi-directional loading**
3. Expand conclusions to **multi-directional cyclic loading**
4. Compare with **numerical** analyses for validation and perspectives
5. Provide an **experimental database** for future work on shared anchor piles



## 1 - Test set-up and validation

## 2 - Multi-directional loading

- Non-collinearity of the load and of the displacement increments is observed
- The accumulation of resultant displacement seems the highest for unidirectional loading
- The greater the reloading angle is, the less the accumulation of resulting displacement is pronounced

## 3 - Cyclic Loading

- **Uni-directional:** consistent with historical published literature on long-term cyclic loading of piles
- **Cross:**
  - Accumulation of displacement in principal direction: can be significant for large loads
  - Almost no displacement in the loading direction: consistent with common observation on 2-way cyclic loading

## 4 – Experimental vs. Numerical

- A first comparison was conducted comparing the results on the WP2 **Chain\_M.80.1\_Case\_19\_s\_2\_L\_3**
- The Numerical Model accumulates more permanent displacement (in this specific instance)

## 5 – Database

Thanks to the technical team of UGE – CG lab

Stéphane Lerat  
Patrick Gaudicheau

Alexandre Jagu  
Philippe Audrain

Alain Neel



<https://cg.univ-gustave-eiffel.fr/en/>

### 3 papers:

1. ECPMG 2024 (Delft, the Netherlands)
2. ISFOG2025 (Nantes)
3. Journal: International Journal of Physical Modelling in Geotechnics

