

Methodology for floating offshore wind turbine Major Component Replacement (MCR) - Webinar



Floating Offshore Wind Operations and Maintenance (FLOWTOM) project

Laure Cossalter, Tanguy Coquio, France Energies Marines

Benoit Augier, Ifremer

Mélissa Mak, EDF

Pierre Alain Frémont, SBM Offshore

PARTNERSHIP:



With the financial support of:



2. Basin tests for numerical model validation

Part II – Validation of numerical model



Tanguy Coquio, FRANCE ENERGIES
MARINES



- **Solution:**

- **Floater:** VoltturnUS-S Semi-submersible + IEA 15MW turbine
- **Vessel:** Reduced WK tanker

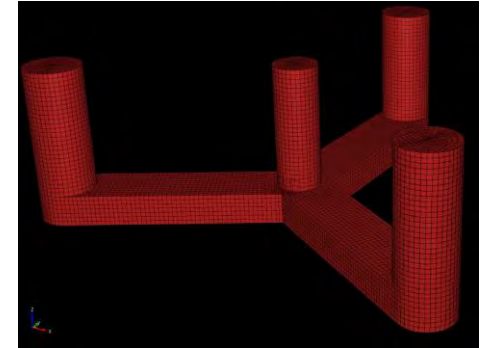

- **Numerical model:**

- **Software:** SIMO v4.26.2 operated in the SIMA v4.6.3 workbench
- **Hydro:**
 - Radiation-Diffraction model
 - Linear hydrostatic stiffness
 - Additional quadratic and linear damping
- **Analysis:** Frequential + Time Domain
- **Mooring:** Taut mooring lines calibrated with catenary chain equivalent mooring stiffness
- **Dynamic Positioning:** Linearized stiffness matrix + Linear Damping

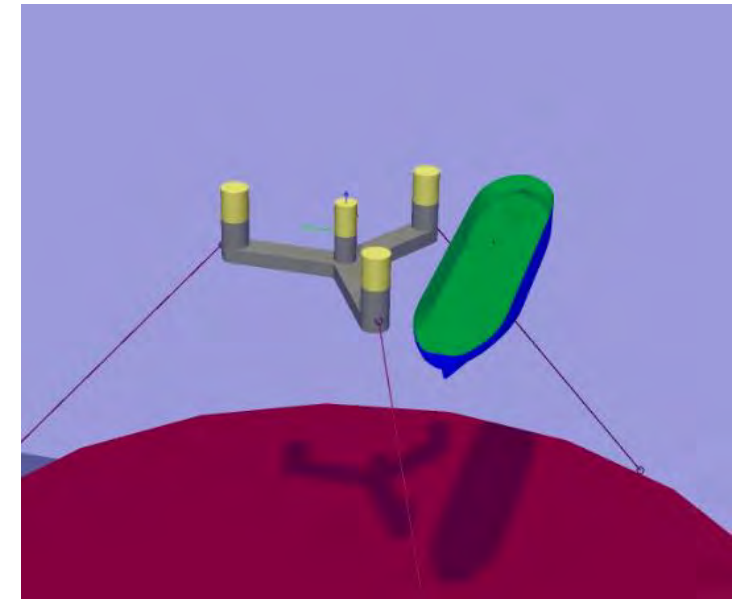

Basin test result analysis – Objectives

- Main Objective:
 - Validation of basin numerical model
 - Coupling effects
 - RAOs comparisons
 - Stiffness & Damping effects on each body
 - Decay test
 - RAOs comparison
 - Calibration of the “main” FLOWTOM Numerical model:
 - VUS
 - WK
 - VUS + WK
- Secondary Objective :
 - Low frequency motion analysis

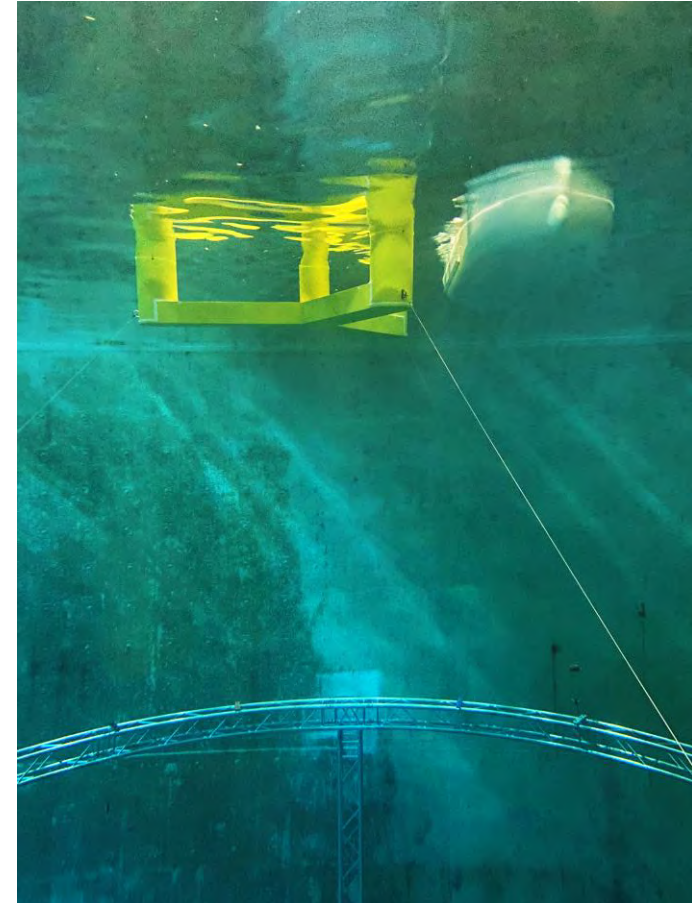

Basin test result analysis – Test Matrix

FLOWTOM basin test program (v5), 8-19th April 2024

VUS only (semi-sub)

WK only (ship)

Both VUS & WK

yet to be run

Wave tests, assuming decay WK, decay VUS, pull-out WK, and pull-out VUS @0 ° are done earlier

	Monday 08	Tuesday 09	Wednesday 10	Thursday 11	Friday 12	weekend	Monday 15	Tuesday 16	Wednesday 17	Thursday 18	Friday 19
8h - 9h	REG01+03	REG19+26	REG11+12	IRR01	REG01		config change	IRR03	IRR02 +45°	IRR13	dismantling
9h - 10h	REG05+13 0°	REG28+29 +90°	REG13+14	REG17+19 +90°	REG03+05		VUS+WK	IRR13	IRR03	REG11+12 +45°	
10h - 11h	REG12+11	IRR25	REG15+16	IRR320(20)	REG11+12		+ decay WK	IRR01bis -90°	IRR11	REG16 +45°	
11h - 12h	config change	intall WK + remove VUS	RG11 + IR01 +90°	conf ch WK&VUS	REG13+16		without DP	IRR15	IRR13	IRR1116	
12h - 13h	VUS only		IRR02	+ remove VUS	REG01+03	IRR01 0°	REG11	REG11bis	IRR01bis	decay VUS wo/ spr.	
13h - 14h	pullouts+decays		IRR03	REG05+11 0°	IRR11	REG12	config change	remove VUS	IRR 11 +45°	dismantling	
14h - 15h	REG03+11	REG03+11	IRR11	REG12+13	IRR12	REG13 -90°	VUS+WK	IRR 13			
15h - 16h	REG12+13	REG12+13 +90°	IRR01bis	REG16	IRR13	REG14+15	REG11+12	rem WK + inst VUS			
16h - 17h	REG14+16 +90°	RG16+3104	remove WK	install VUS	IRR01bis	RG16 + IR01	REG13+14 +45°	IRR11 +45°			
17h - 18h	REG18	install VUS	IRR320 +90°		IR320(20N)	IRR02	REG15+16				
							IRR01				

configuration 0°

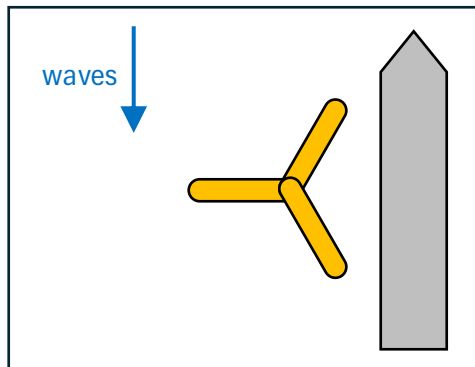

configuration +90°

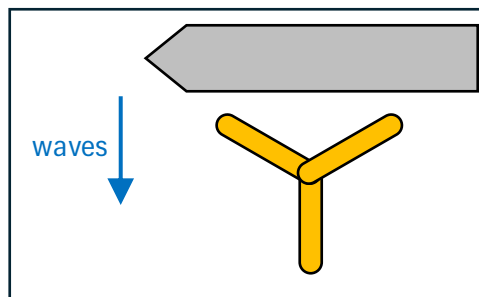

configuration -90°

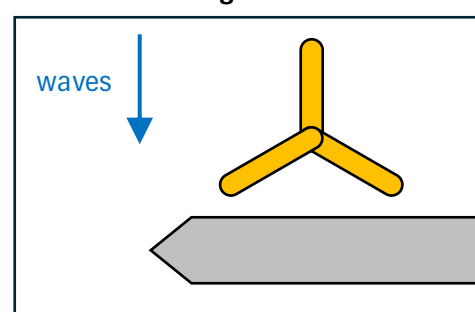

configuration +45°

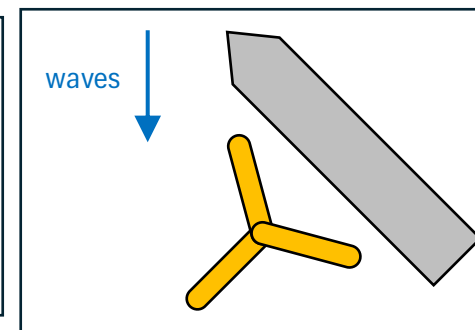

Basin test result analysis – Test Matrix

Reg wave	H (m)	T (s)
REG01	1.5	7
REG02	1.5	8.5
REG03	1.5	10
REG04	1.5	11.5
REG05	1.5	13
REG06	1.5	15
REG07	1.5	17
REG08	1.5	19
REG09	1.5	21
REG11	3.0	7
REG12	3.0	8.5
REG13	3.0	10
REG3104	3.0	10.4
REG14	3.0	11.5
REG15	3.0	13
REG16	3.0	15
REG17	3.0	17
REG18	3.0	19
REG320	3.0	20
REG19	3.0	21
REG21	8.0	7
REG22	8.0	8.5
REG23	8.0	10
REG24	8.0	11.5
REG25	8.0	13
REG26	8.0	15
REG27	8.0	17
REG28	8.0	19
REG29	8.0	21

Irr wave	Hs (m)	Tp (s)
IRR01	1.5	7
IRR02	1.5	9
IRR03	1.5	11
IRR04	1.5	13
IRR05	1.5	15
IRR11	3.0	7
IRR12	3.0	9
IRR13	3.0	11
IRR14	3.0	13
IRR15	3.0	15
IRR320	3.0	20
IRR23	8.0	11
IRR25	8.0	15
IRR1116	11.0	16



- Basin configurations:
 - WK with DP
 - WK FreeFloating
 - VUS with Mooring
 - VUS FreeFloating
- Numerical model configurations:
 - WK with DP RAW
 - WK with DP recalibrated
 - VUS with Mooring RAW

RAW = Numerical model built according to the specification report. It will then consider parameter such as water depth, spring stiffness, mock-up Mass/Inertia BUT is not recalibrated (stiffness, damping) due to basin test.

Decay test objectives:

1. Understand the impact of Mooring and DP on the global behavior
2. Recalibration of stiffness and Damping Data

Basin test result analysis – Decay Test – WK Basin: DP vs FreeFloating

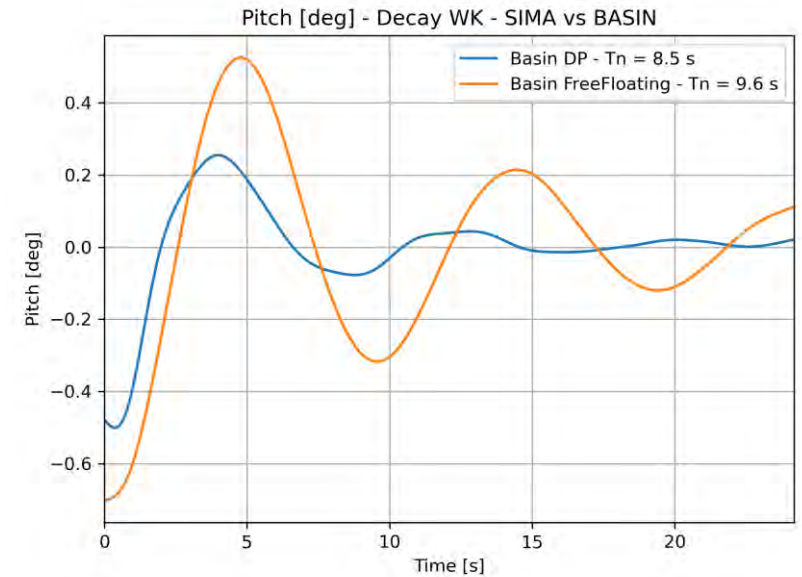
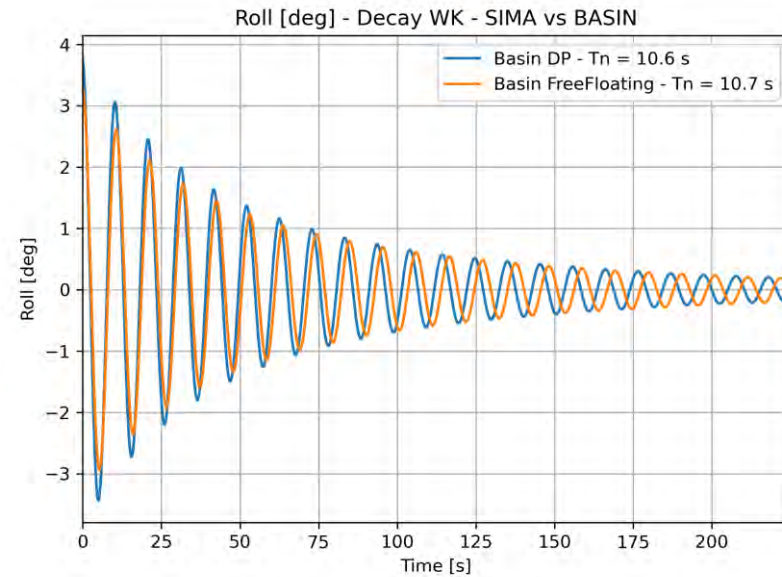
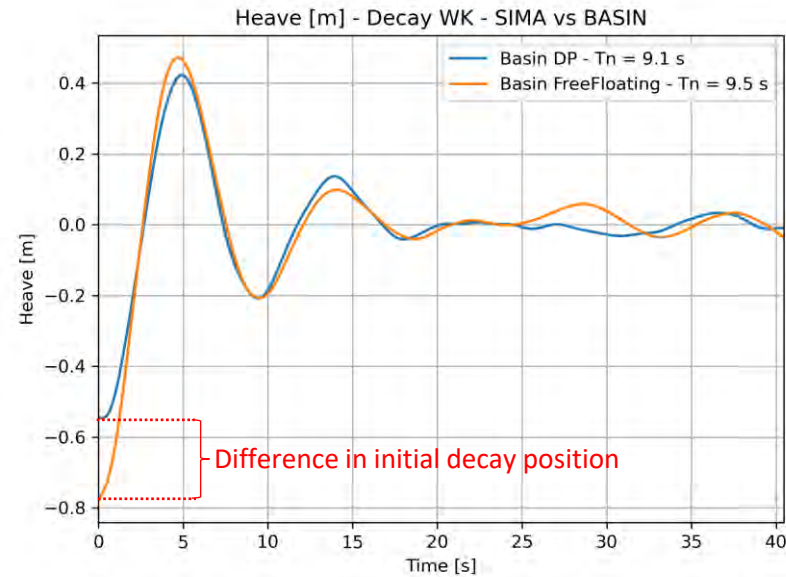

- Expectations:
 - The DP system should not impact the motion in Heave roll and pitch
- Observations:
 - The DP leads to a stiffer response (lower T_n) for these 3 DOF.
 - The DP seems to introduce damping for the pitch motion

Basin test result analysis – Decay Test – WK : Basin with DP vs Numerical

Surge [m] - Decay WK DP - SIMA vs BASIN

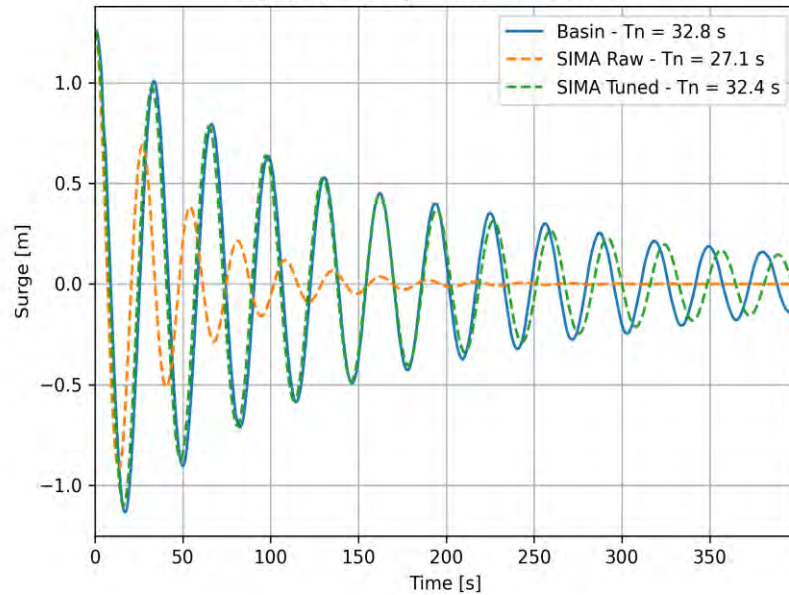

Sway [m] - Decay WK DP - SIMA vs BASIN

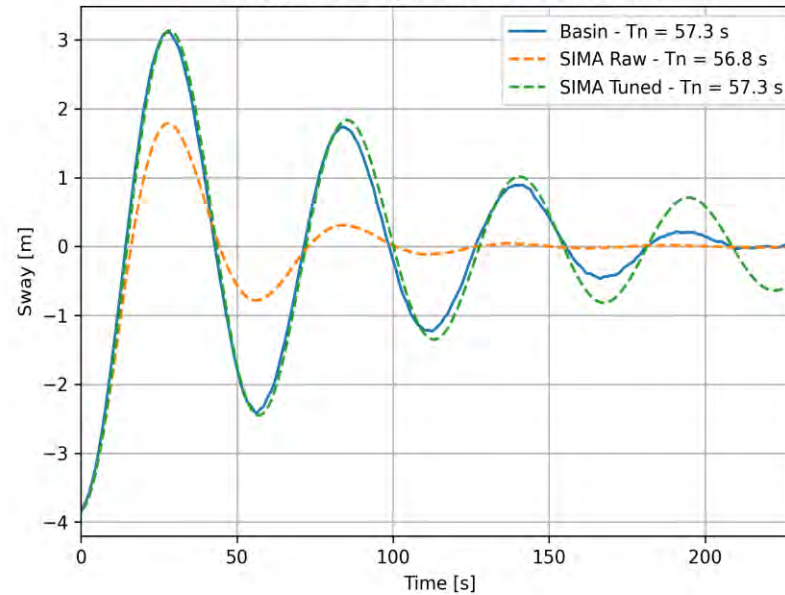

Heave [m] - Decay WK DP - SIMA vs BASIN

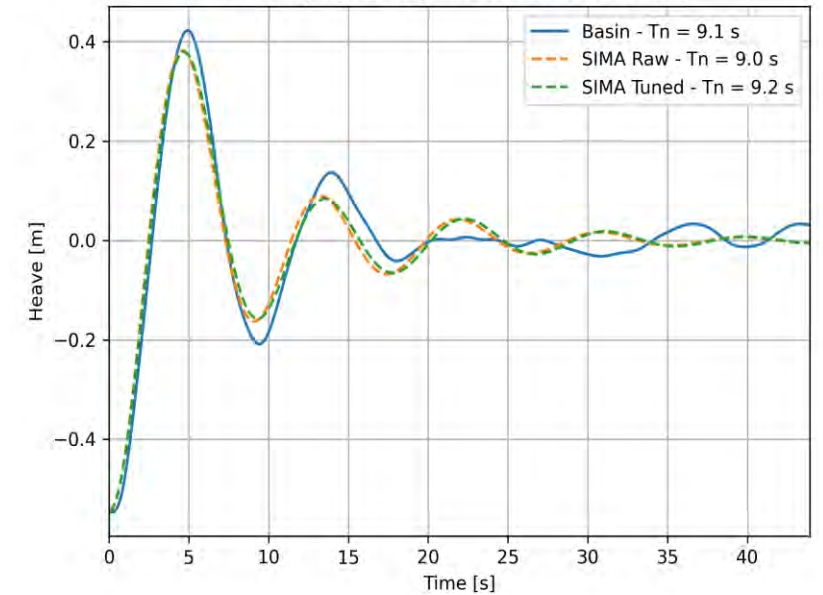

- Observations:

- The Basin DP system is leading to significant differences in stiffness and damping
- The recalibrated SIMA model reaches a good fit for these 3 DOF
- Even with no additional damping in heave, the numerical model is damped compared to basin observations

- Tuned parameters:

- Hydrostatic stiffness
- Additional Linear damping
- Additional quadratic damping

Basin test result analysis – Decay Test – WK : Basin with DP vs Numerical

Roll [deg] - Decay WK DP - SIMA vs BASIN

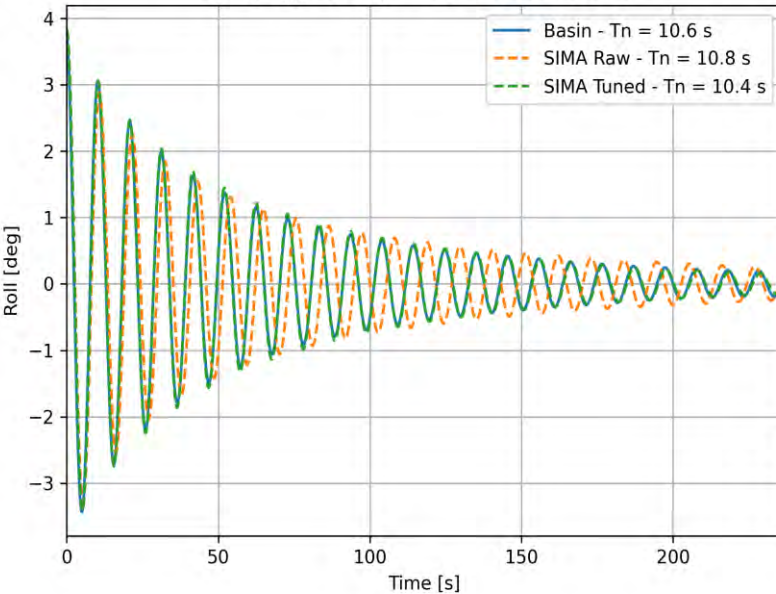

Pitch [deg] - Decay WK DP - SIMA vs BASIN

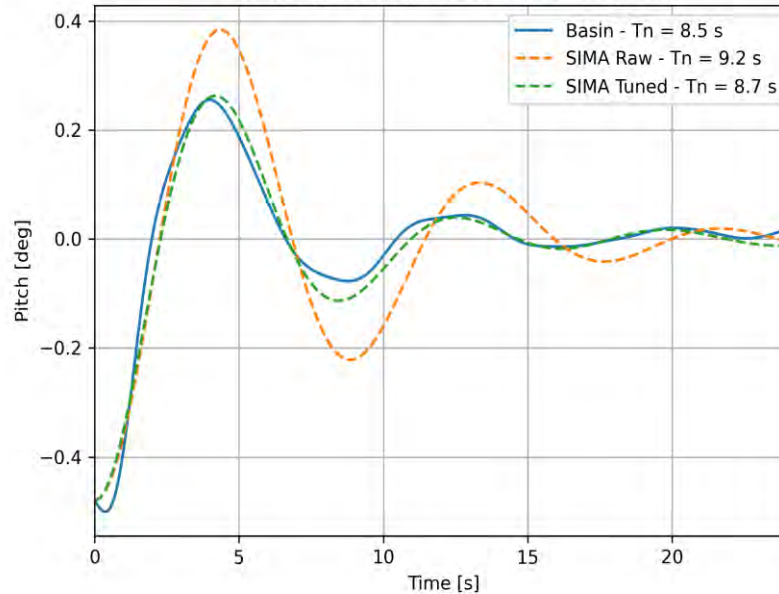

Yaw [deg] - Decay WK DP - SIMA vs BASIN

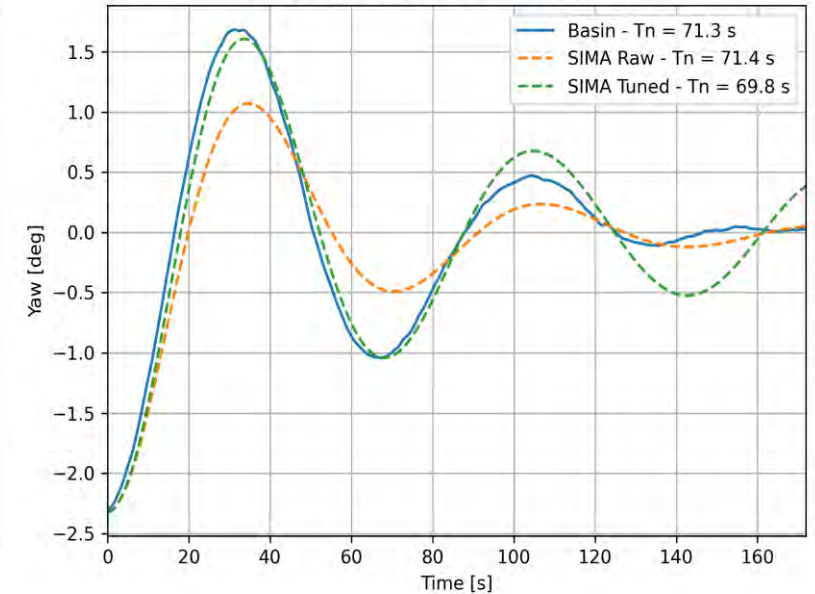

- Observations:

- The Basin DP system is leading to significant differences in stiffness and damping
- The recalibrated SIMA model reaches a good fit for these 3 DOF
- Bilge keels are producing the expected result

- Tuned parameters:

- Hydrostatic stiffness
- Additional Linear damping
- Additional quadratic damping

Basin test result analysis – Decay Test – VUS Basin: Mooring vs FreeFloating

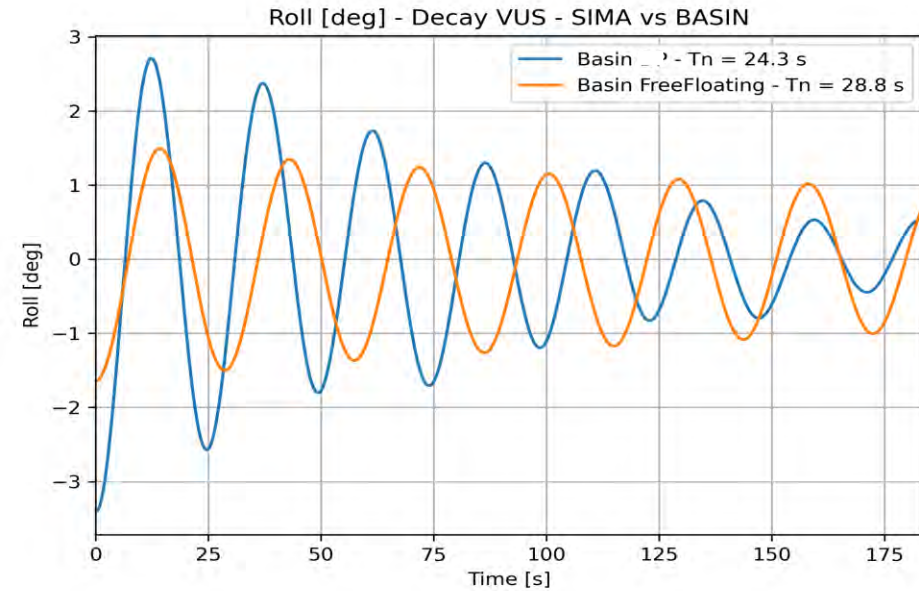
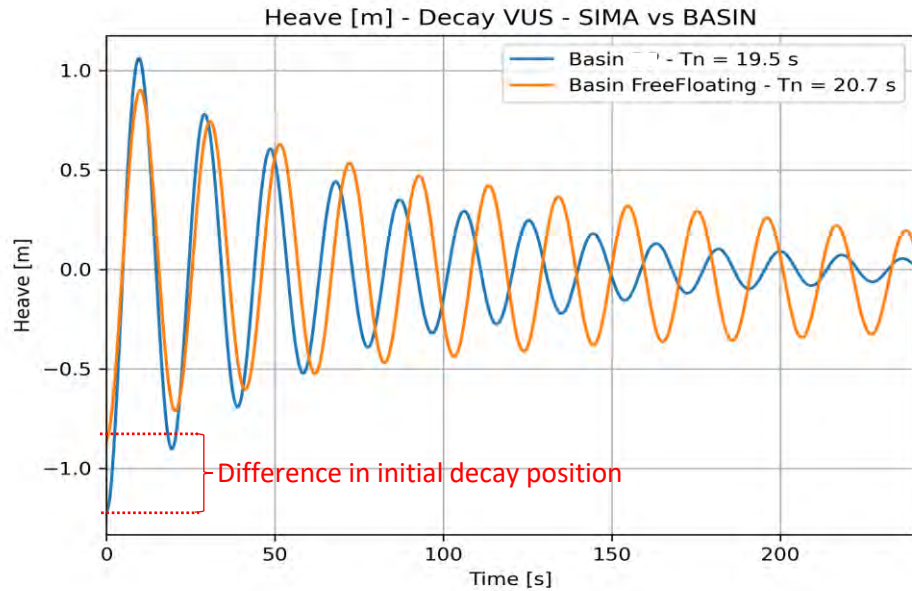

- Expectations:
 - The mooring system is supposed to impact the motion in Heave and Roll
- Observations:
 - The mooring leads to a stiffer response (lower T_n) for these 2 DOF.
 - The mooring seems to introduce damping for both motions

Basin test result analysis – Decay Test – VUS : Basin with Mooring vs Numerical

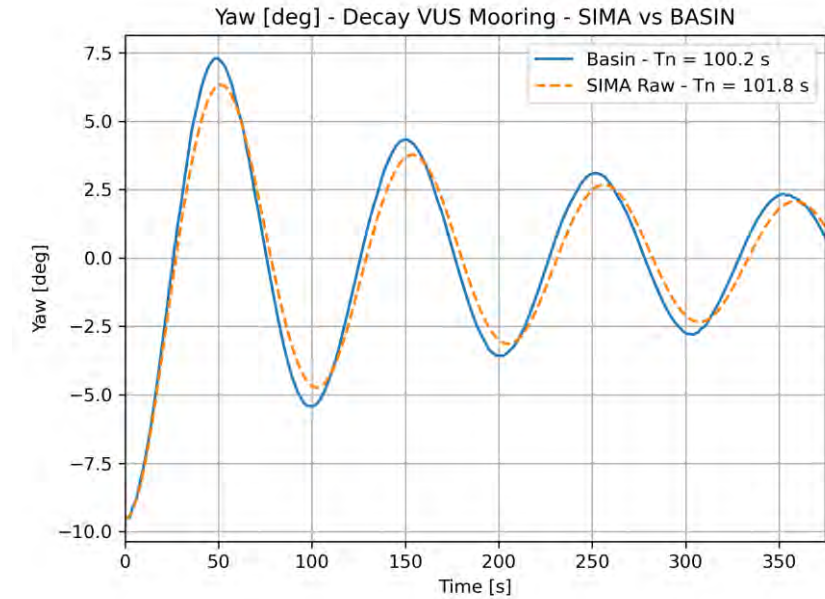
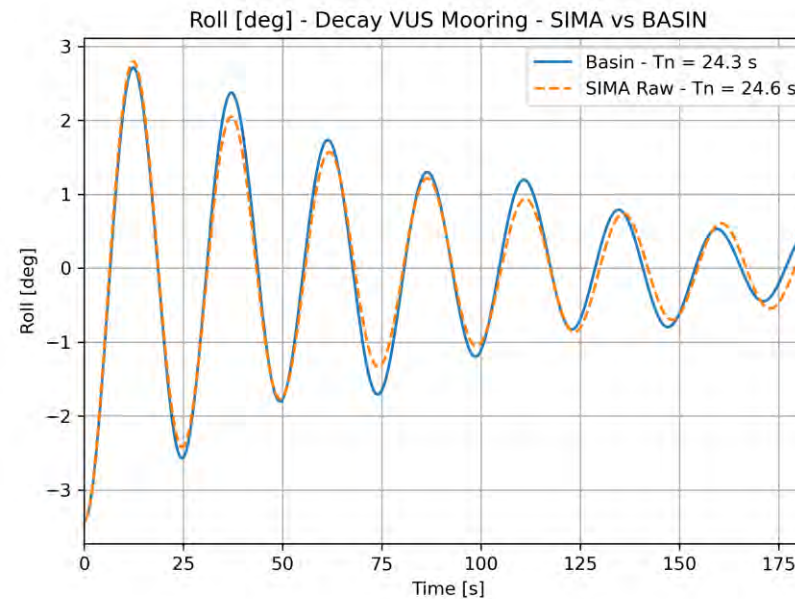
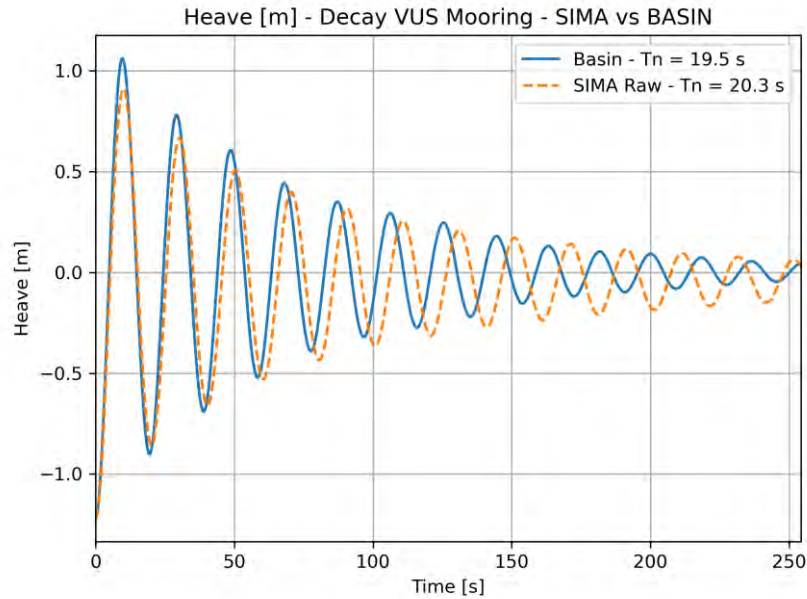

- Observations:

- The RAW numerical model is close to the basin test result
- Here, the basin mooring system is well captured by the numerical model
- No need to recalibrate the model

- Tuned parameters:

- None

- **WK:**
 - The DP system in the basin is leading to a slightly different behavior than the one expected from the basin specification
 - In order to produce an efficient RAO comparison (XP vs numerical), **it was decided to tune the model with additional stiffness and damping for the following RAO study**
 - These modifications are closely related to the complex DP system (4 springs) in the basin.
 - Consequently, the tuned model must not be extrapolated to the main FLOWTOM study for which the DP system is realistic
 - **No recommendation for the main FLOWTOM WK model from decay test analysis**
- **VUS:**
 - The good match between numerical and experimental permits to conclude that the numerical model is accurate for the semi-submersible decay motion
 - **No recommendation for the main FLOWTOM VUS model from decay test analysis**

- Basin configurations:
 - WK Single
 - VUS Single
 - VUS + WK
 - Orientation 0° , 45° , 90° and -90°
- Numerical model configurations:
 - Same as basin test
- Wave types:
 - Unidirectional regular and irregular waves

Wave test objectives:

1. RAO comparison Basin vs Numerical model
2. Coupling effect evaluation
3. Damping effect on the VUS floater
4. Low frequency motion characterization

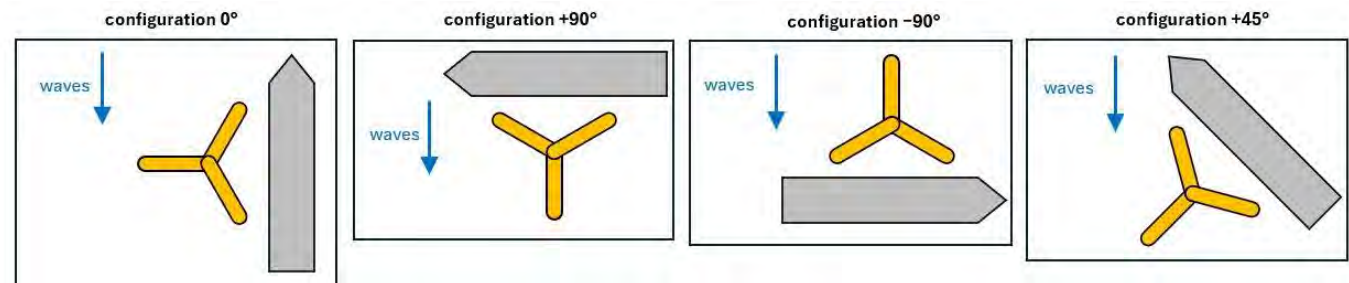

VUS mooring line spring stiffness

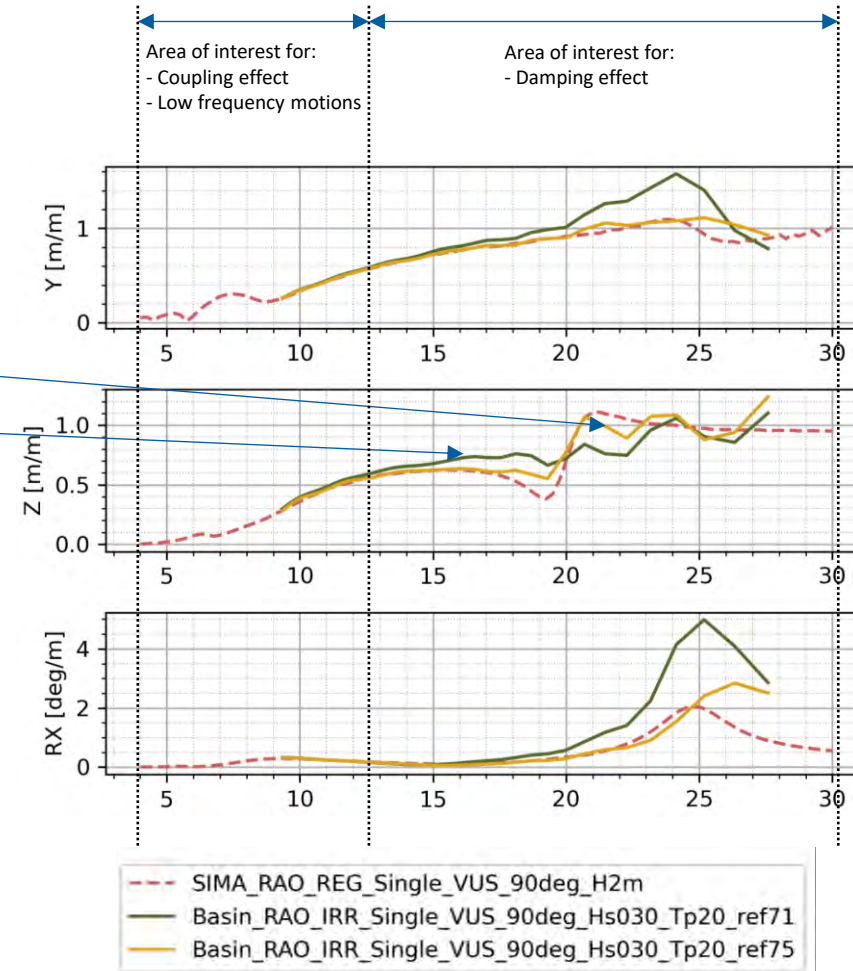
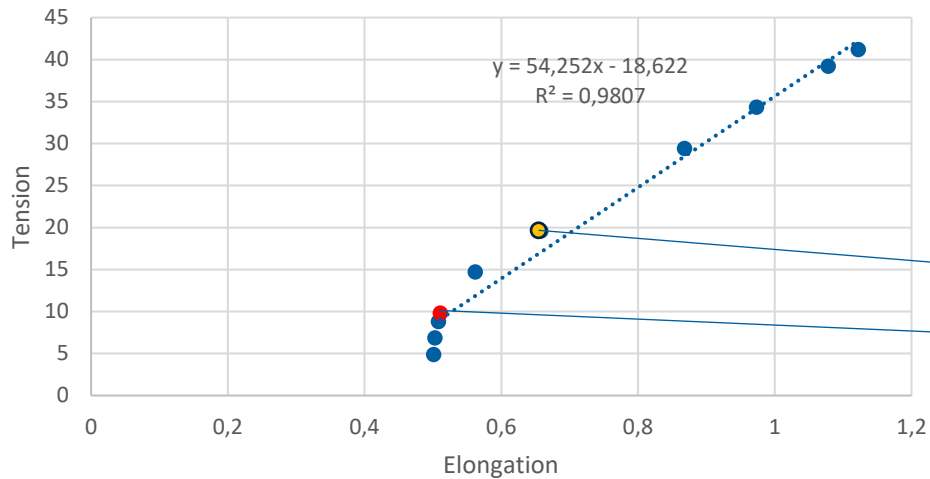

- Observations:

- The initial pre-tension (also used in the main study) is leading to a deviation for $T > 12.5s$ motion. This is due to non-linear behavior of the mooring line for this pretension,
- Not impacting the coupling and low frequency study
- For the damping calibration of the floater, it is necessary to increase the initial pre-tension of the system

Basin test result analysis – Wave Tests – RAOs Post Treatment Methodology

- Basin Regular RAOs:
 - Discrete points extracted for the amplitude and phase
- Basin Irregular RAOs:
 - Cross-spectrum analysis
 - Concatenation of results to obtain the best fit
- SIMA Numerical RAOs:
 - Discrete points extracted from Time-Domain with regular waves analysis

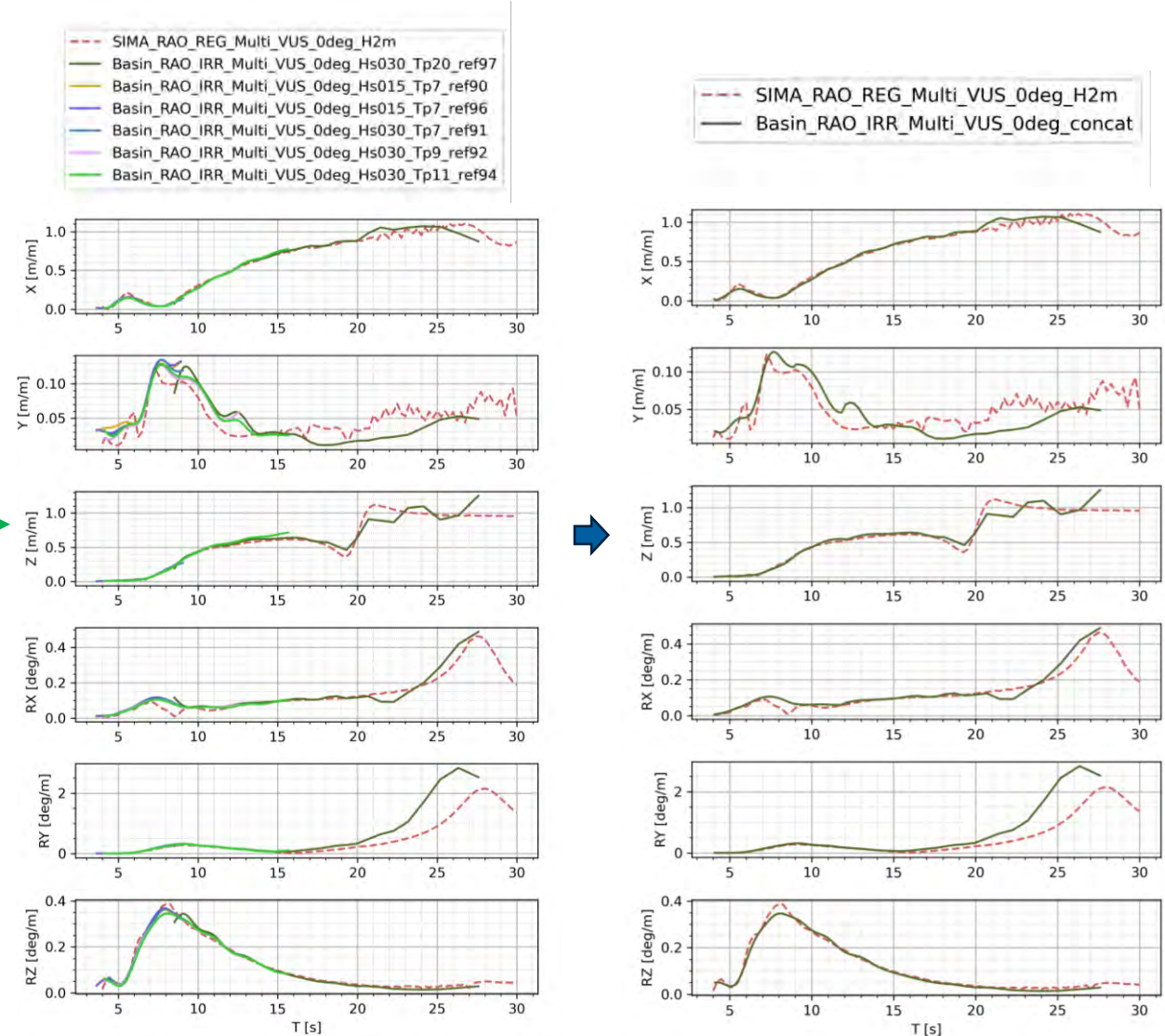

Basin test result analysis – Wave Tests – Single WK 90°

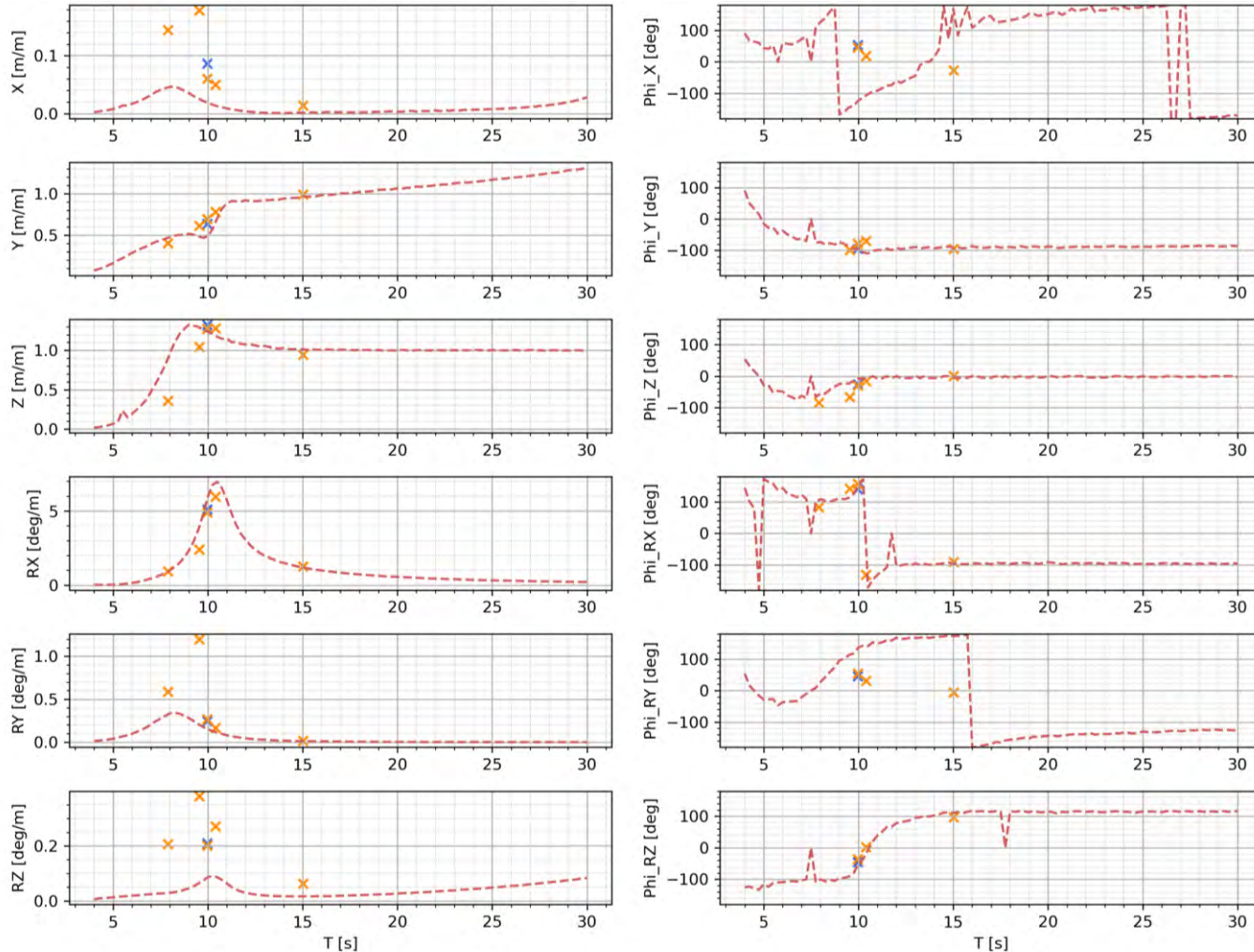

Observations:

- Only regular basin waves here
- The roll motion is well captured by the numerical model
- Sway motion is well captured as well
- For heave motion, a shift of the peak response towards higher period is present in the basin
- Phases comparison is satisfying

Basin test result analysis – Wave Tests – Single WK 0°

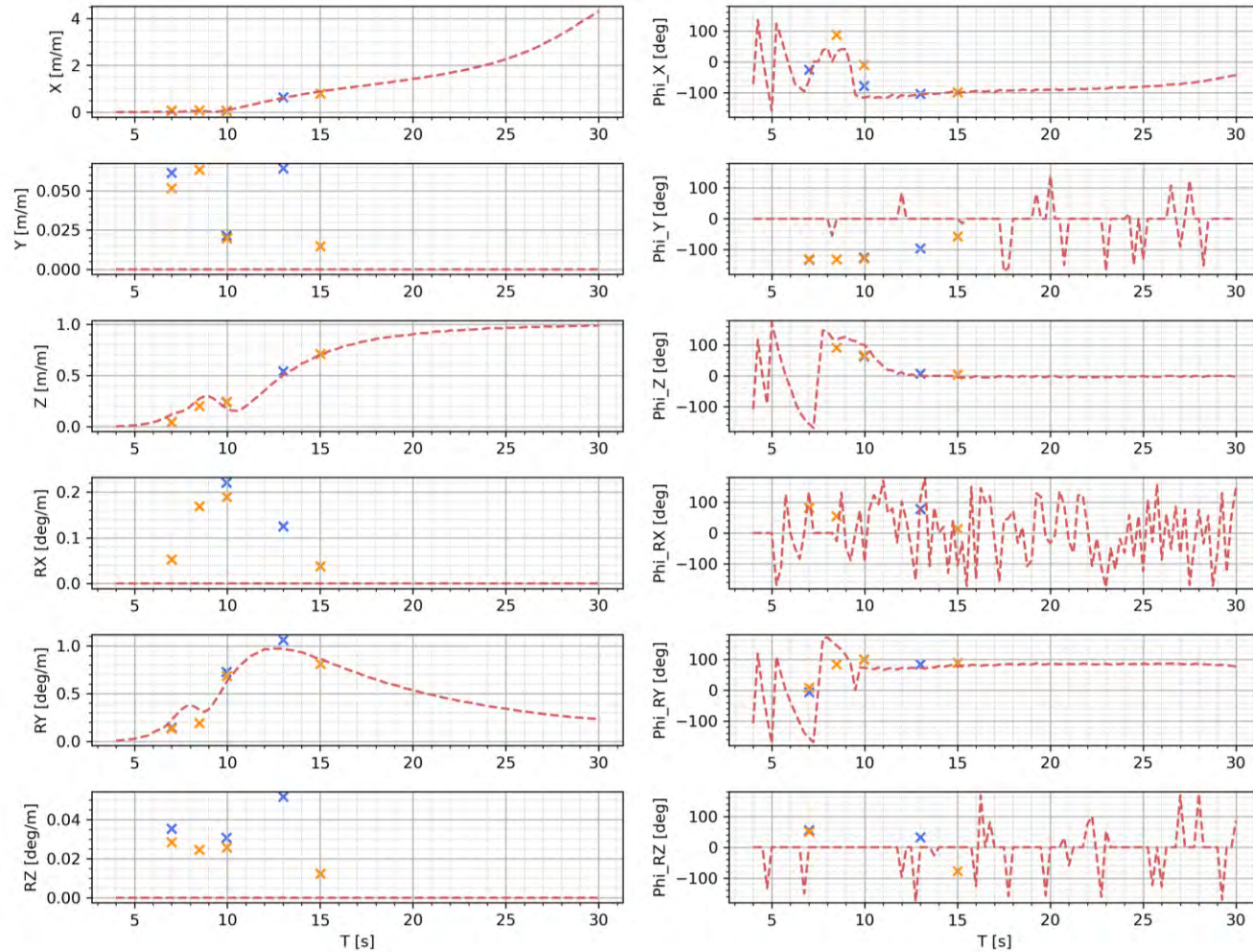

Observations:

- Only regular basin waves here
- Surge motion is well captured
- Heave motion is well captured
- A slight offset in pitch motion is captured at 6-8 s
- Roll motion is slightly excited in the basin, even for 0° waves
- Phases comparison is satisfying

Basin test result analysis – Wave Tests – Single VUS 90°

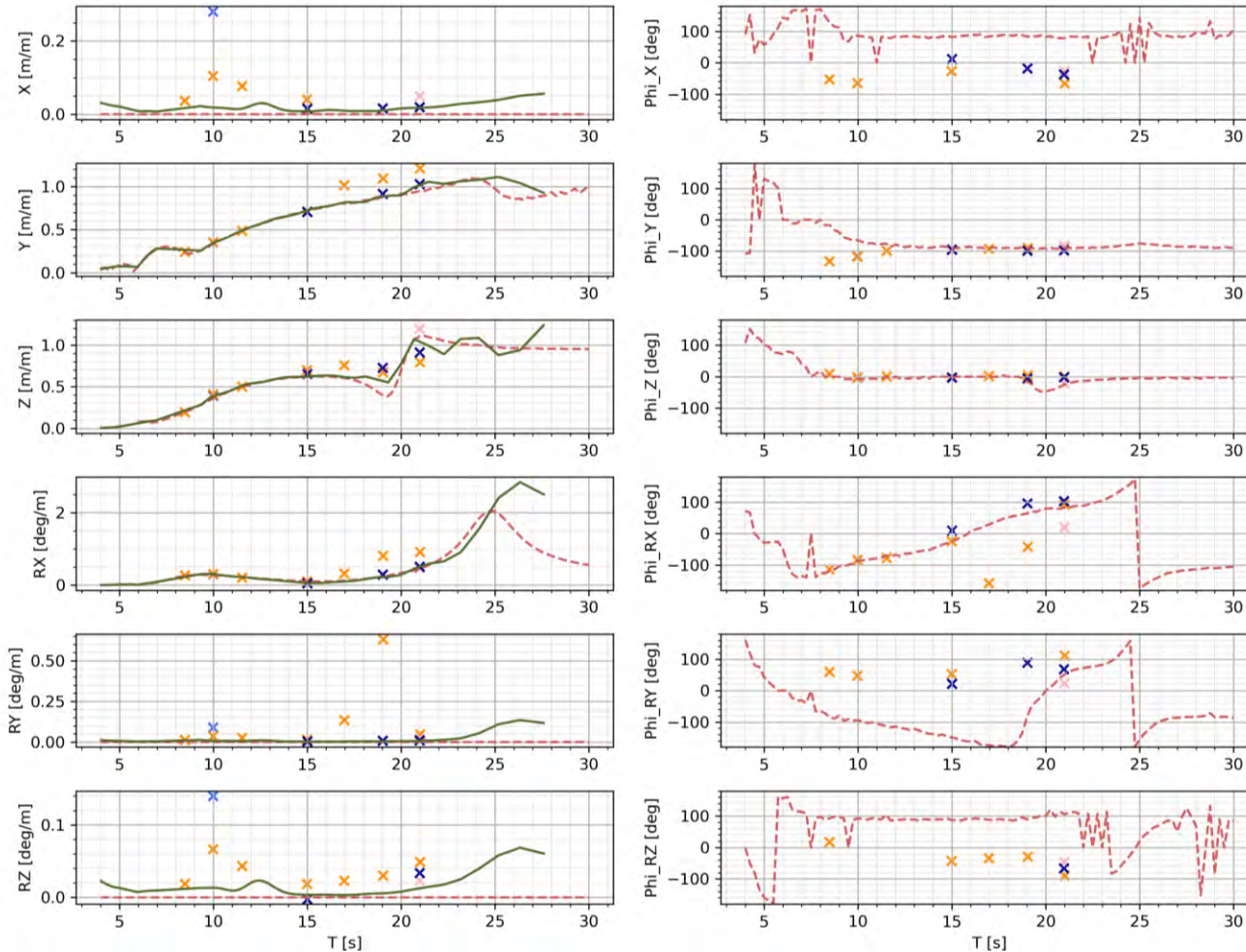

Observations:

- Very close match between experimental and numerical for $T < 16$ s
- For $T > 16$ s, a slight offset appears between curves due to the mooring stiffness issue
- Oscillation in heave at $T > 21$ s are due to the wave spectrum which is missing energy for high periods
- Regular points from Basin are following the same trend
- Phases comparison is also following the same trend

Basin test result analysis – Wave Tests – Coupling effect on VUS 90°/-90°

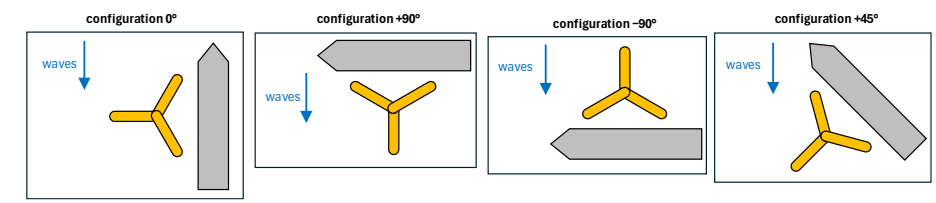
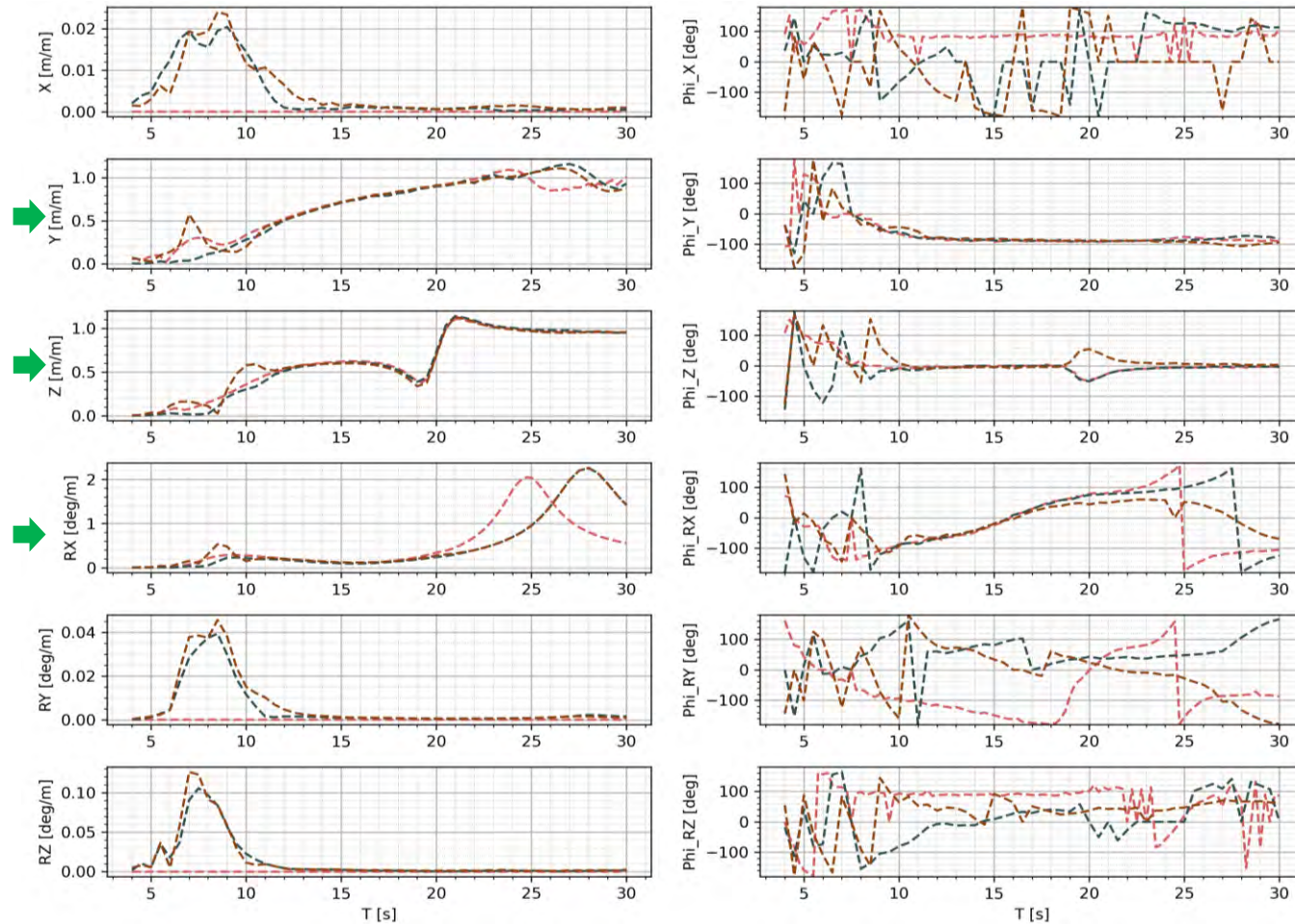

Observations:

- Coupling effects are appearing for $T < 15s$
- The comparison is highlighting a shelter (+90°) or reflection (-90°) effect on the VUS from the WK for these periods
- A RAO offset is detected for 20s+ period in Roll

Basin test result analysis – Wave Tests – Coupling effect on VUS 90°/-90°

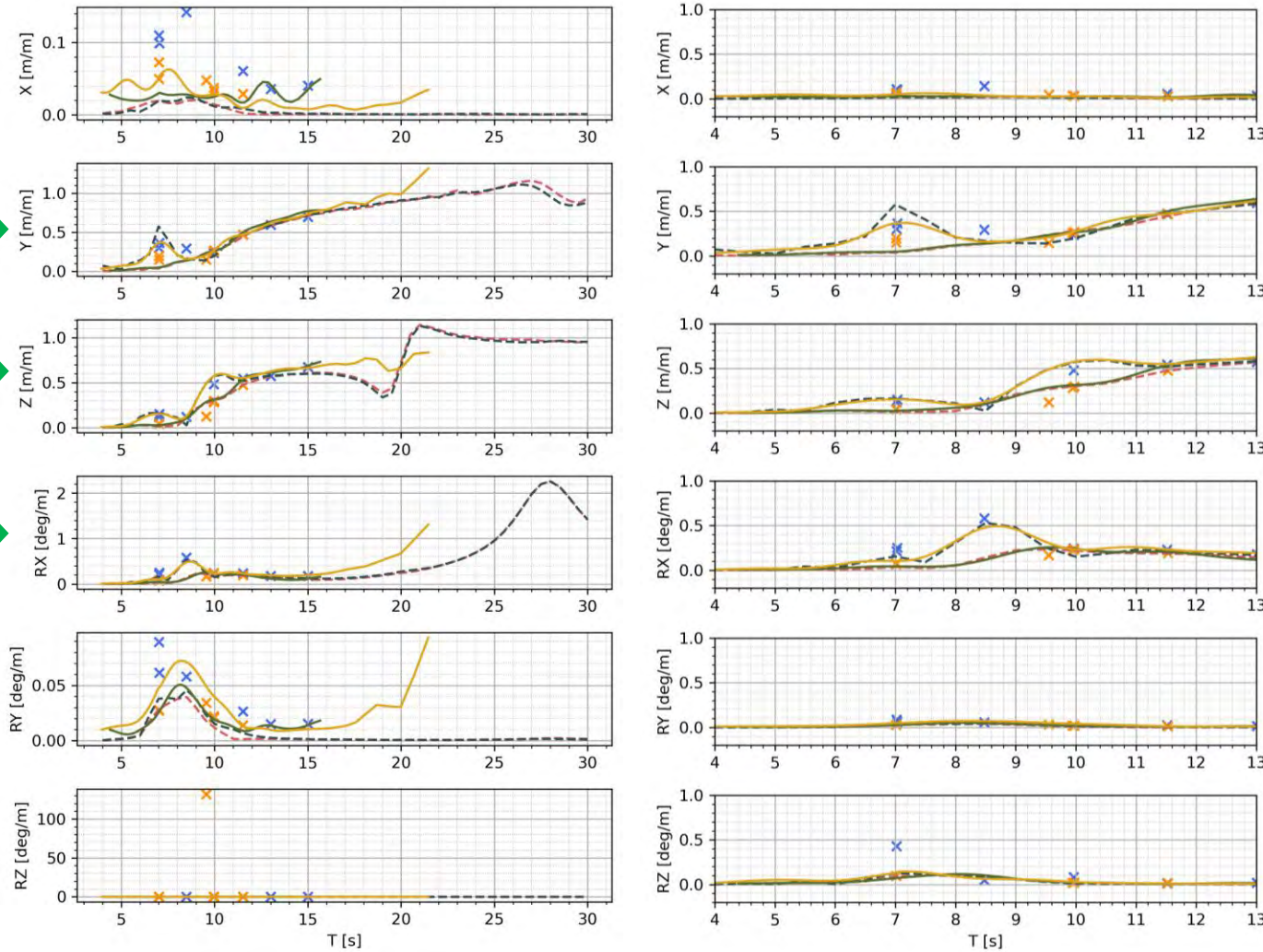

Observations:

- Coupling effects (<15s) are completely captured by the numerical model

Basin test result analysis – Wave Tests – Coupling effect on WK 90°/-90°

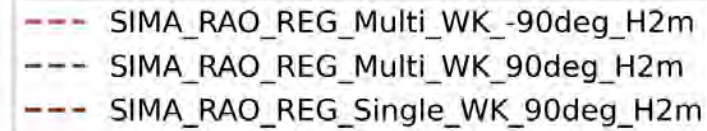
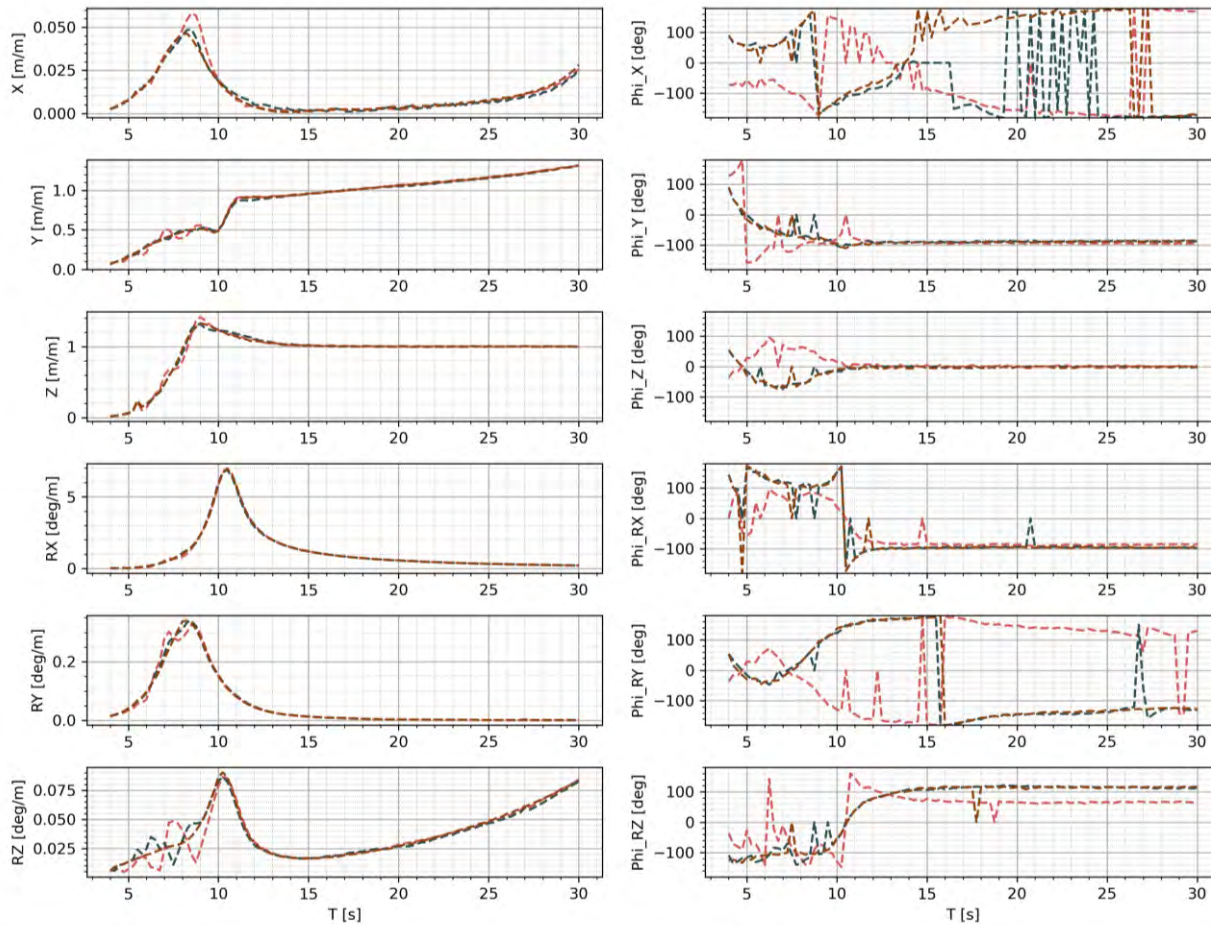

- Observations:
 - Minor coupling impact on the WK

- **WK:**
 - The tuned numerical model provide an accurate representation of the WK motions, both for coupled and uncoupled situations
 - The WK is not impacted by the presence of the VUS in the basin
 - **No recommendation for the main FLOWTOM WK model**
- **VUS:**
 - Due to the non-linearity of the basin mooring line stiffness at chosen pre-tension, high period ($T > 15s$) RAO are impacted. When the pretension is increased, this issue become less impacting
 - It is then difficult to observe quadratic damping (representing viscous effect) impact at natural period
 - For lower period ($T < 15s$), the tuned numerical model provide an accurate representation of the VUS motions, both for coupled and uncoupled situations
 - The VUS is impacted by the presence of the WK and the shelter effect is well captured by the model
 - **No recommendation for the main FLOWTOM VUS model**

Basin test result analysis – Conclusion & take away messages

- A successful basin test campaign:
 - 150 tests performed during the 2 weeks of campaign
 - Mockup were achieving the required specification (Geometry, mass & Inertia)
 - The innovative spring DP system was proven efficient for our specific study
- Decay test and Regular/Irregular wave analysis are showing satisfying results:
 - The radiation/diffraction model is accurate, both for the VUS and the WK, single or coupled
 - Viscous effect (not included with the potential theory) added by the mean of additional damping (linear and quadratic) are well captured by the numerical model:
 - Morison element for the VUS are providing an accurate comparison
 - Additional Roll damping + Bilge keel model for the WK are providing an accurate comparison
 - Natural periods of the systems are well captured
- Minor issues were detected:
 - Stiffness linearity issue for mooring lines → difficult to observe VUS RAOs for $T > 15s$
 - WK basin DP system is slightly impacting unwanted DOF (Heave, Roll, pitch)

→ **The numerical model of the main FLOWTOM study is validated**