

Methodology for floating offshore wind turbine Major Component Replacement (MCR) - Webinar



FLoating Offshore Wind Operations and Maintenance (FLOWTOM) project

Laure Cossalter, Tanguy Coquio, France Energies Marines

Benoit Augier, Ifremer

Mélissa Mak, EDF

Pierre Alain Frémont, SBM Offshore

PARTNERSHIP:



With the financial support of:



3. Case study : operability definition of MCR steps

Part II – Case of transfer of heavy package from vessel to floating offshore wind turbine



Melissa Mak, EDF R&D



Case 1 : Package system installation

Number of cases run : 234

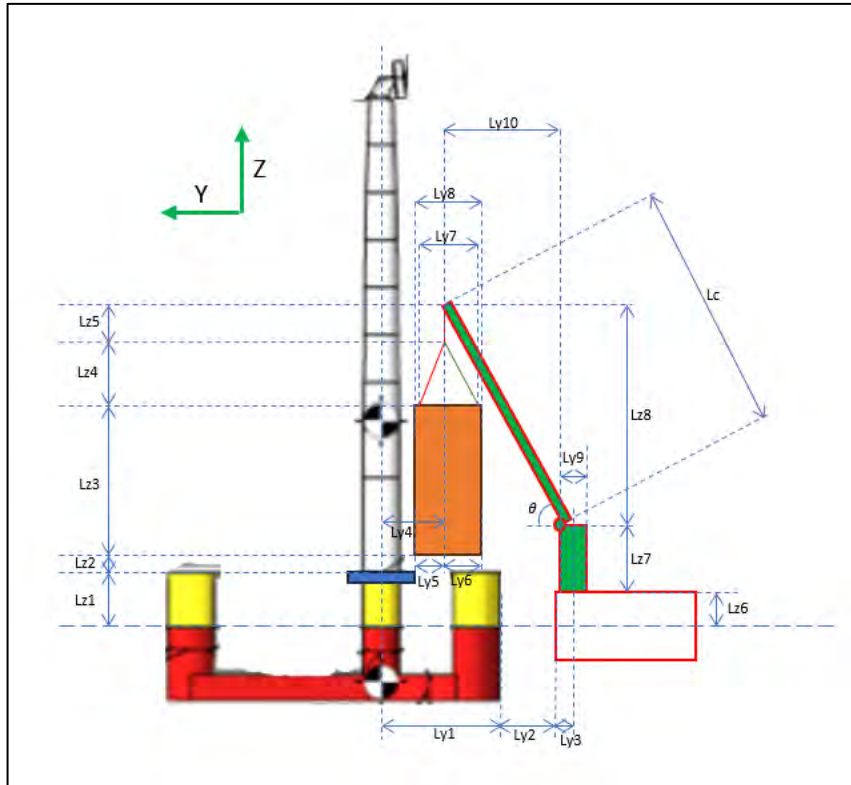

Case : 300 t lift weight

Model:

- No wind drag and No 2nd order wave forces on FOWT and WK
- Wind drag on the lift

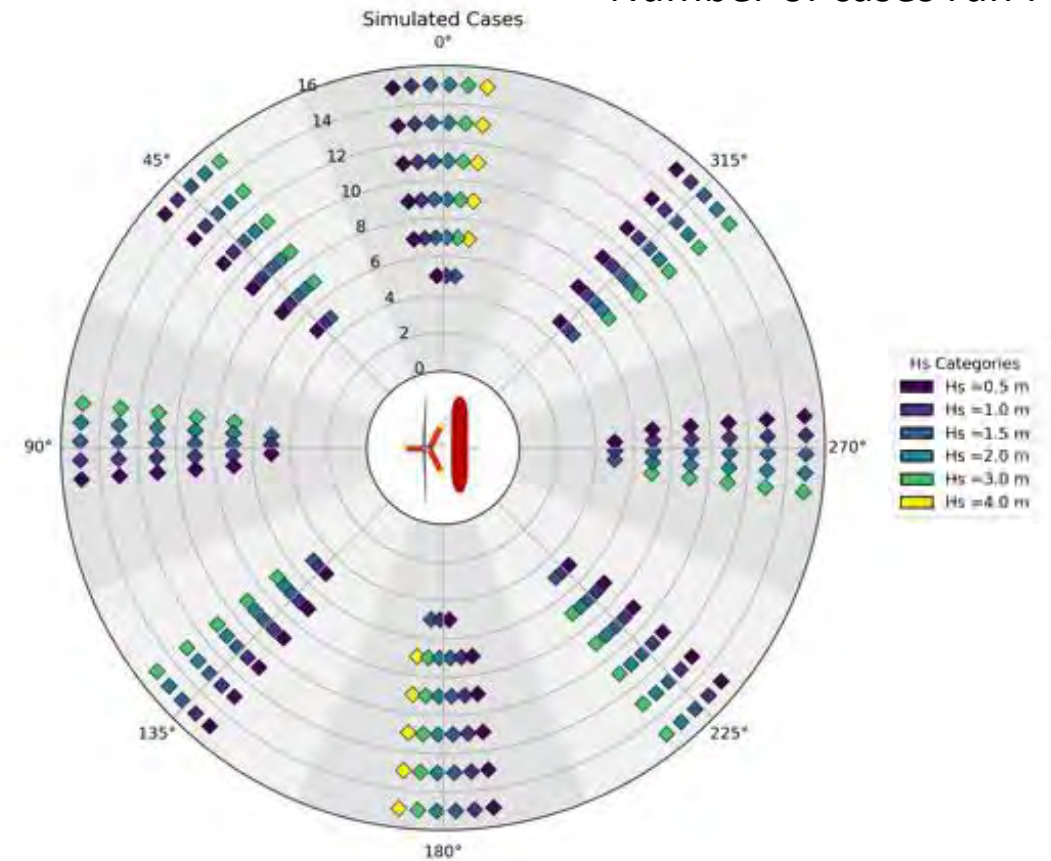

Case 1.1.1 : Package system installation without tugger line

EDF - VUS

Outcome of Global Success Criteria
0°

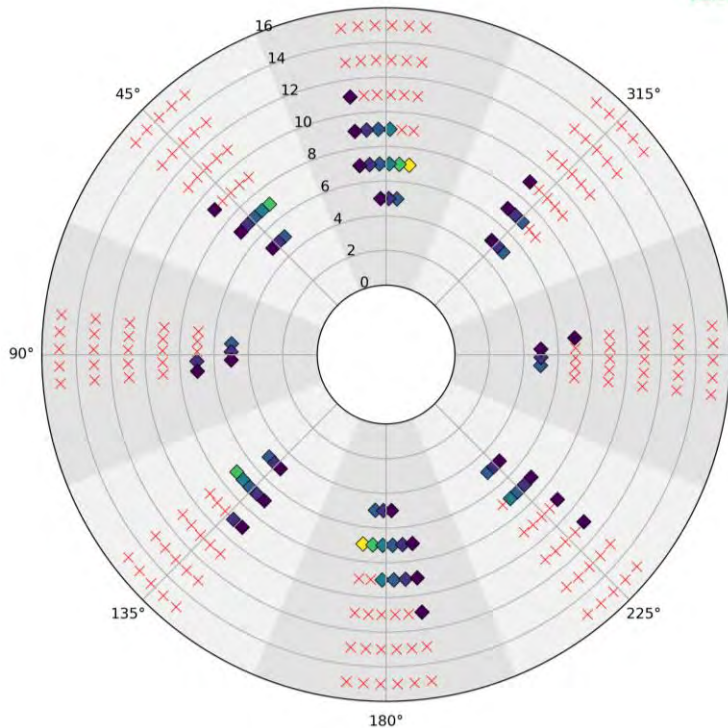

High Wind Speed; Wind-Wave Direction Aligned
 Failed Case

SBM - F4W™

Outcome of Global Success Criteria
0°

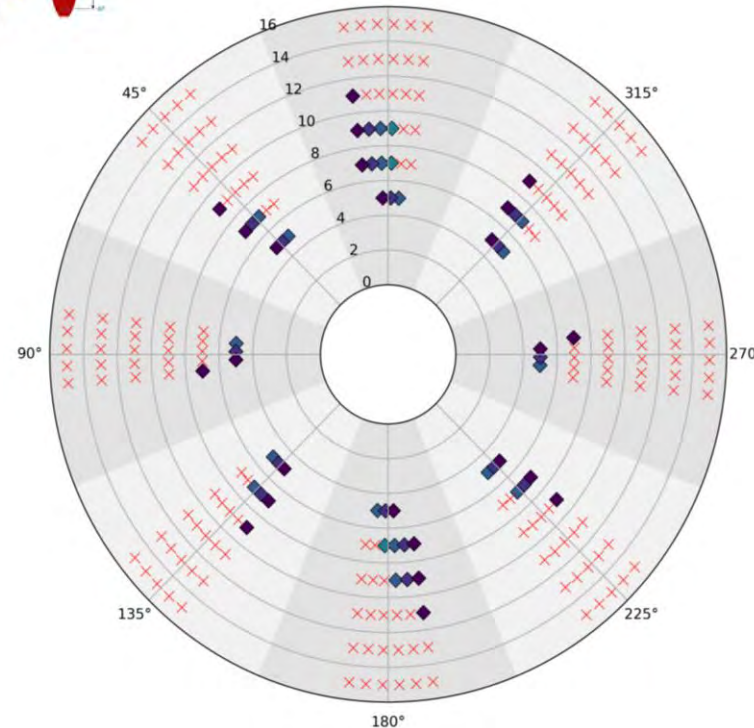
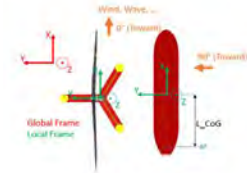

Polar Angle = Wave Direction
 Polar Radius = T_p

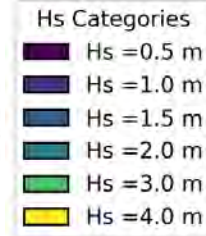

- Preferred waves direction, parallel to the boat (0°, 180°)
- Worst waves direction, perpendicular to the boat (90°, -90°), aggravated when hitting the boat (-90°) due to roll excitation
- Low success at $T_p \geq 9s$ due to bodies natural periods ($WK_{Rx} = 10,5s$; $Pac = 15s$)
- Differences between floaters due to model hypothesis

Case 1.1.2 : Package system installation with tugger line

EDF - VUS

Outcome of Global Success Criteria
0°

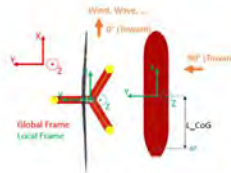
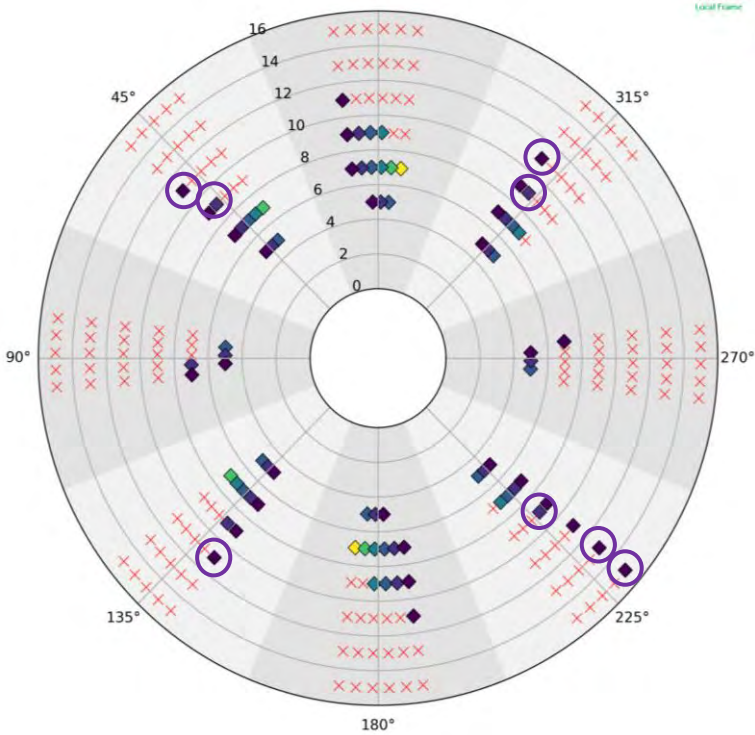

SBM - F4W™

Outcome of Global Success Criteria
0°

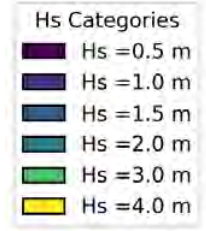
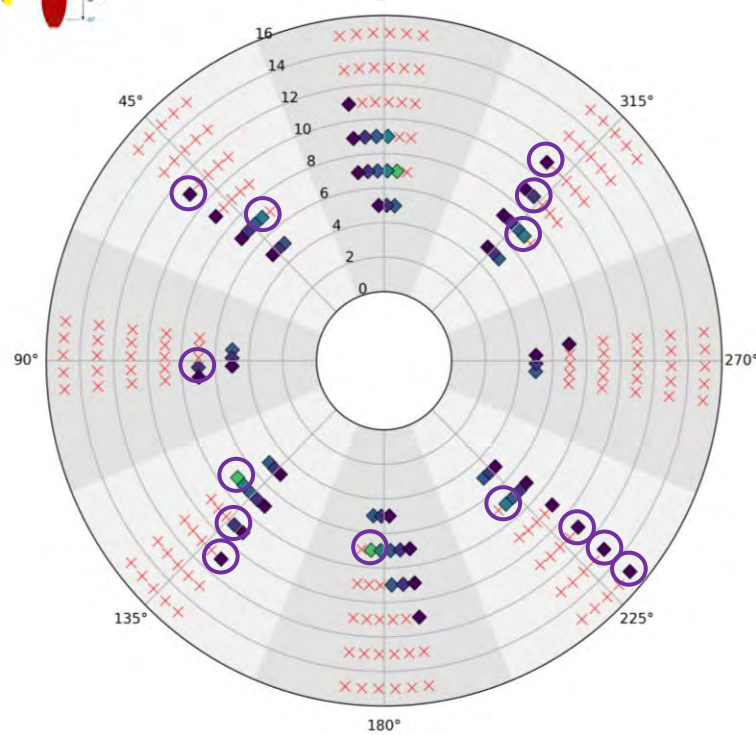

8 more cases passed with tugger addition

13 more cases passed with tugger addition

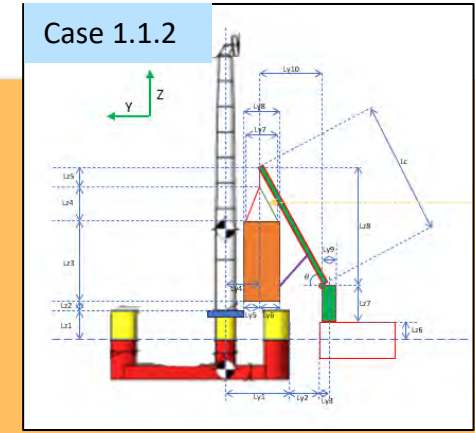

- Same global observations
- **Slightly higher success at $T_p \geq 9s$ with tugger lines**
- Differences between floaters due to model hypothesis

Case 1.1.2 : Package system installation with tugger line

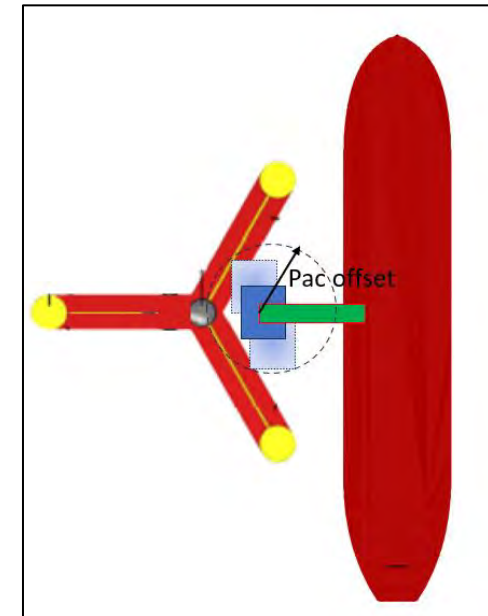
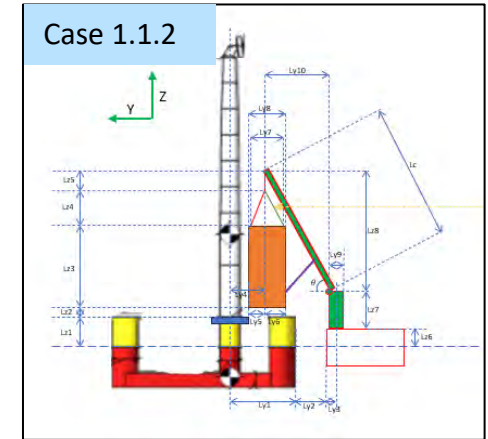
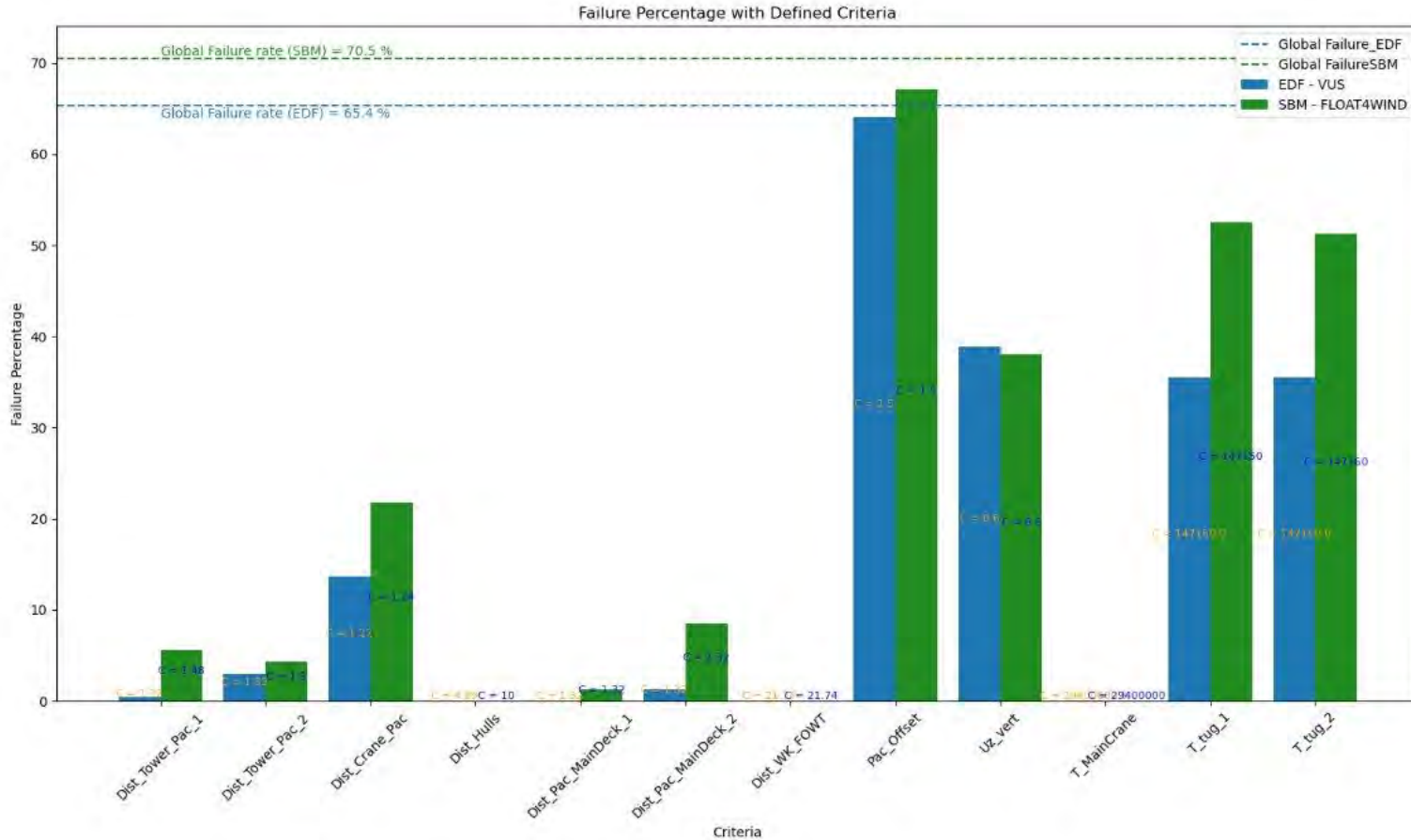

- Package offset is the main limiting criteria
- Tugger lines limit some failures, but their tension appear to be a limiting criteria (by design)

Case 1.1 : Package system installation

Global rate of success (% of simulations run out of 234 cases)

Cases	VUS	F4W
Package system without tugger line	30.8 %	25.2 %
Package system with tugger line	34.6 %	29.5 %

- **/!\ differences on the model of winches between DIEGO and ORCAFLEX**
- **Using tugger lines slightly improve the results (4%)**
- **Levers for improvement:** design of tugger line; pendulum length; crane positioning on vessel (at vessel stern > vessel heading facing waves); crane type (knuckle boom)

Case 1.1.2 : Package system installation with tugger line

/!\ operation duration not included in this operability analysis – default duration : 3h simulation

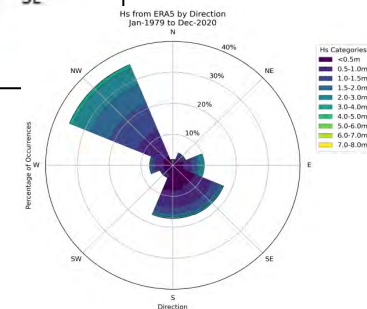
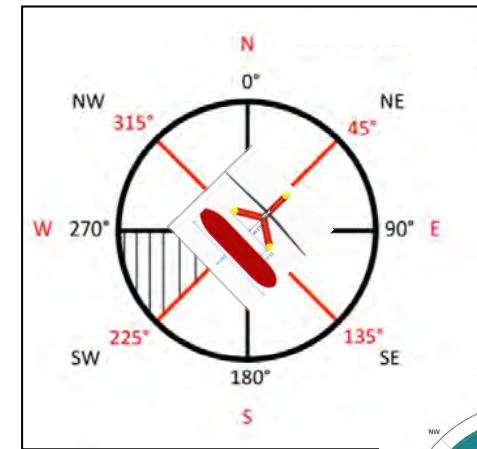
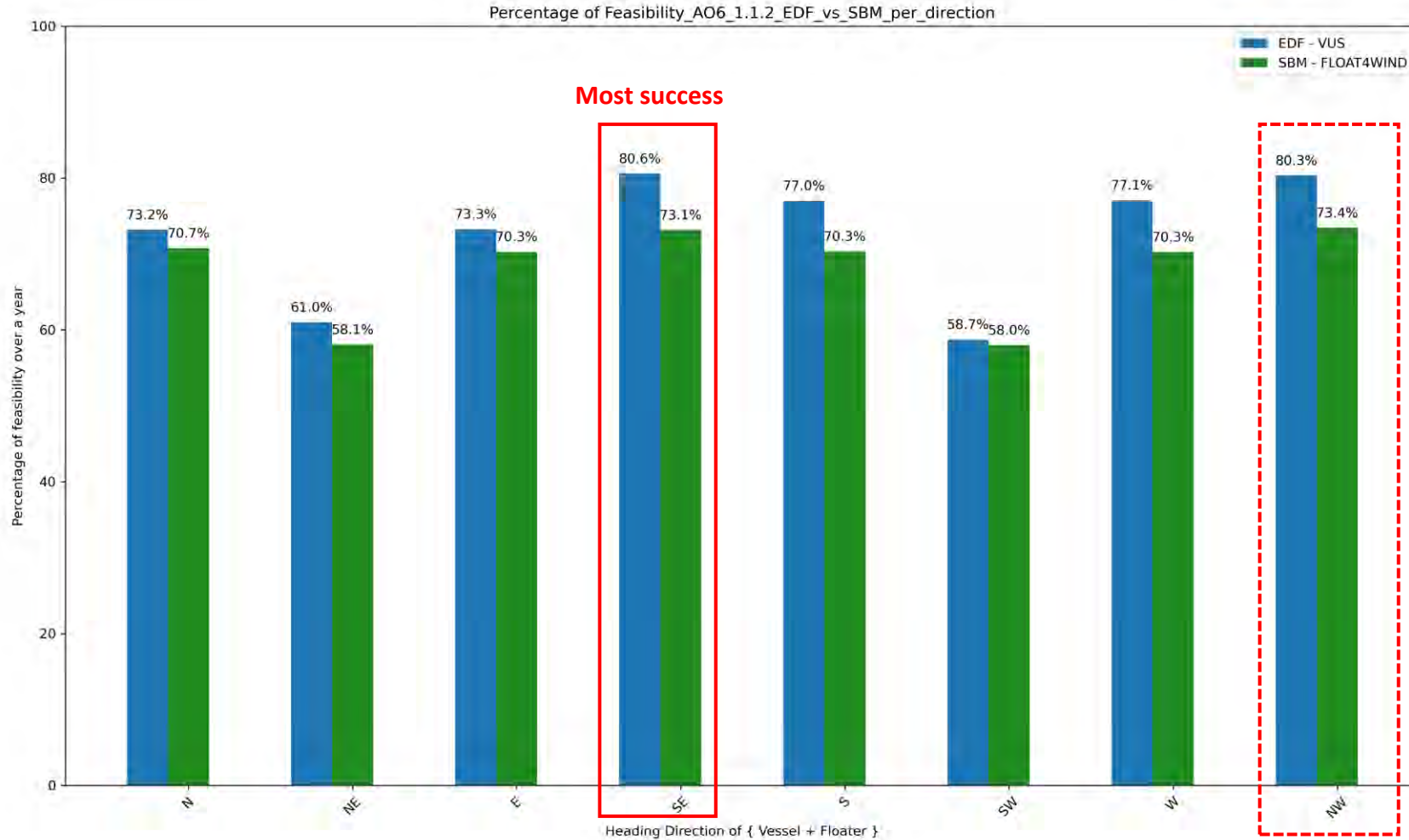

Case 1.1.2 : Package system installation with tugger line

/!\ operation duration not included in this operability analysis – default duration : 3h simulation

EDF - VUS

SBM - F4WTM

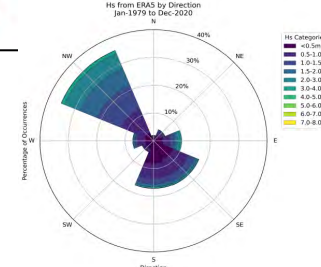
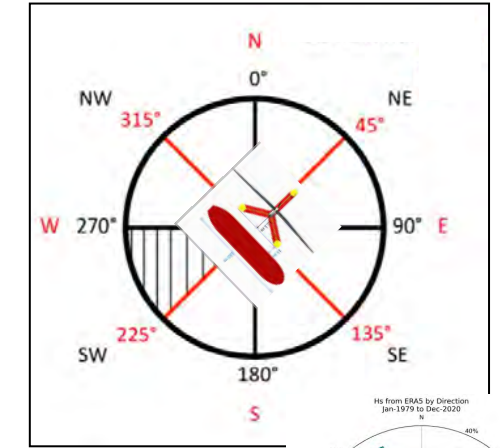
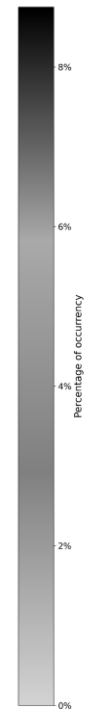
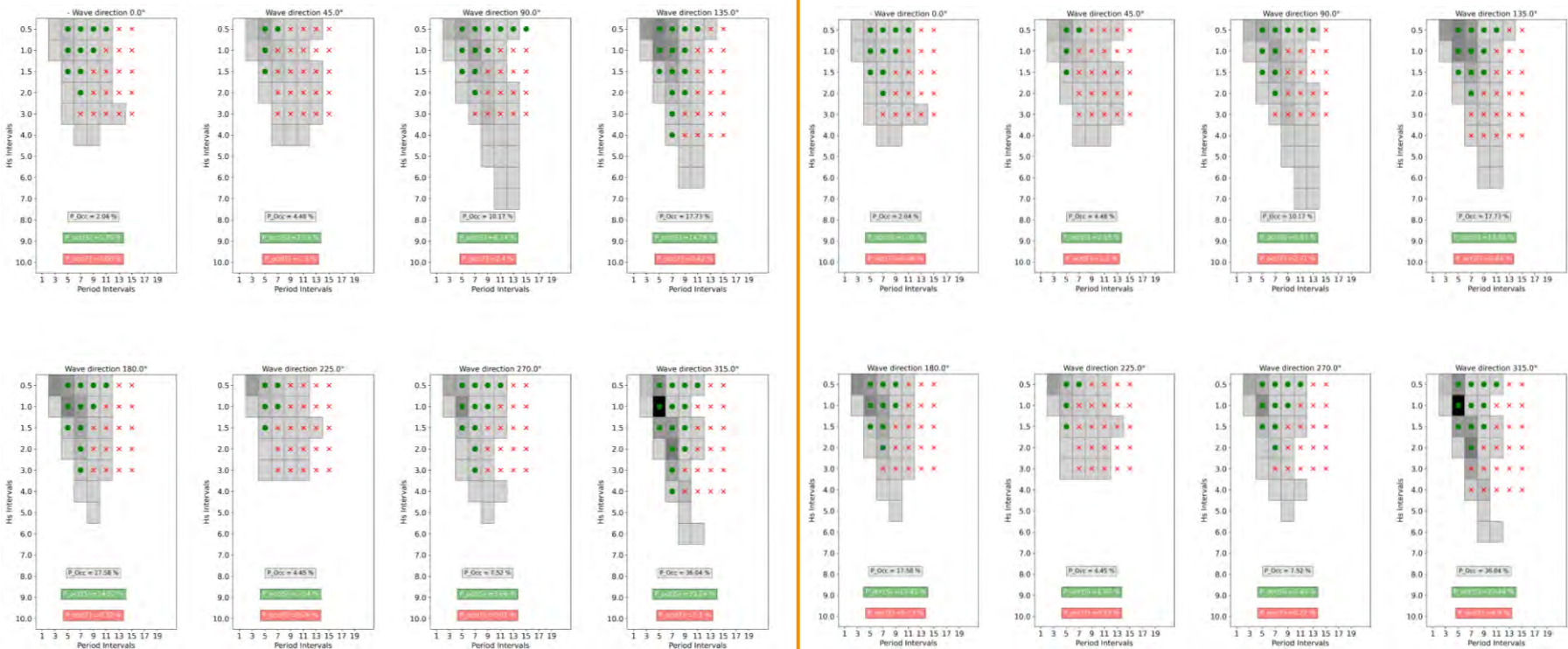

Case 1.1.2 : Package system installation with tugger line

/!\ operation duration not included in this operability analysis – default duration : 3h simulation

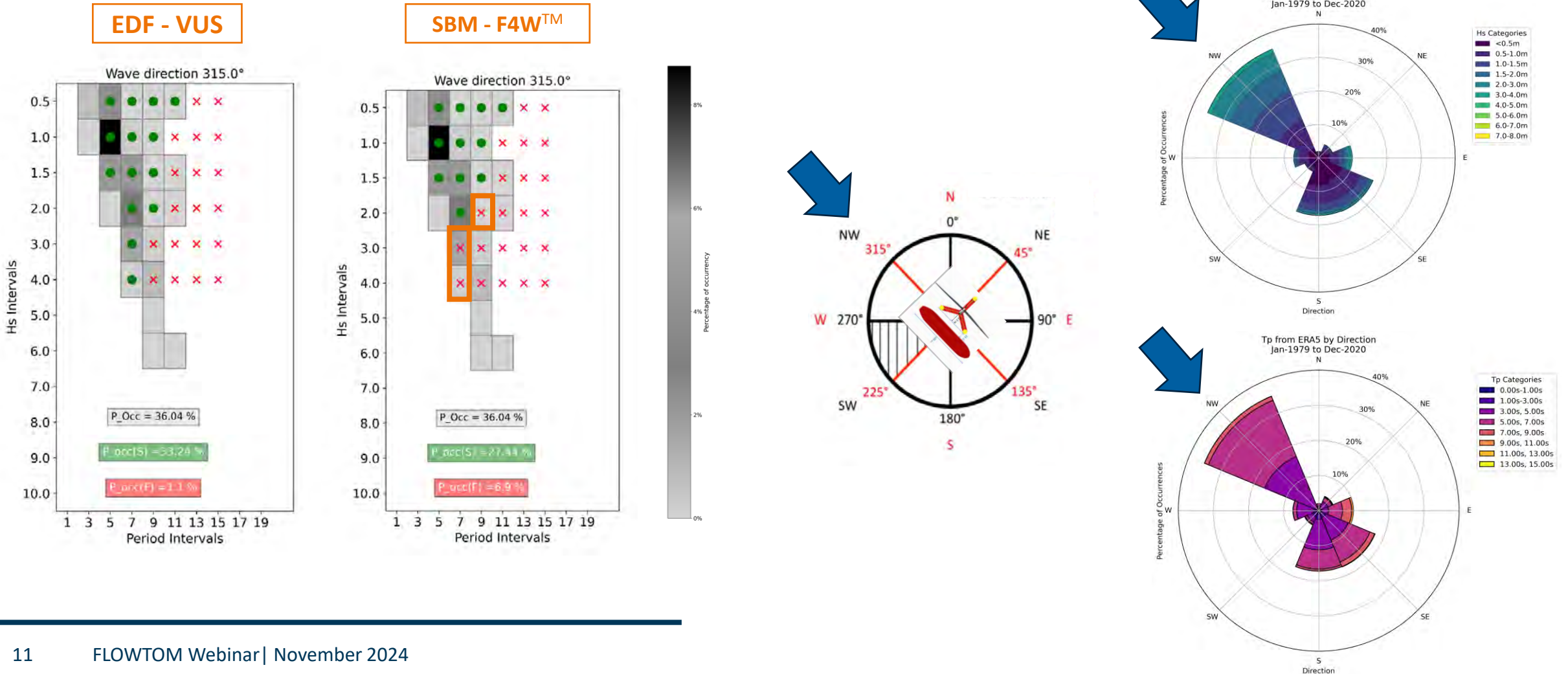

Case 1.1.2 : Package system installation with tugger line

/!\ operation duration not included in this operability analysis – default duration : 3h simulation

% of Feasibility_AO6_1.1.2_EDF_vs_SBM_Direction_SouthEast_scaling to the month

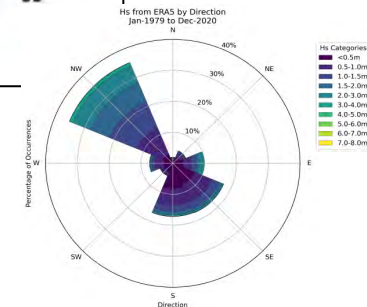
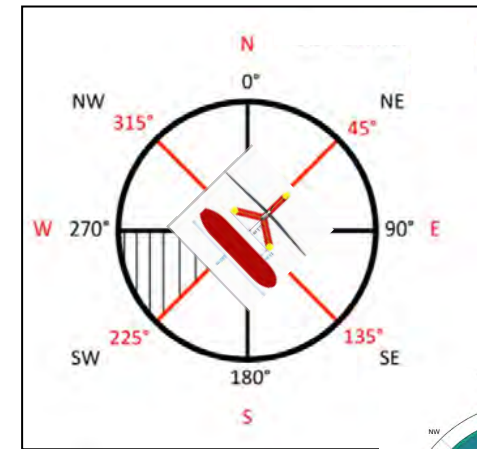
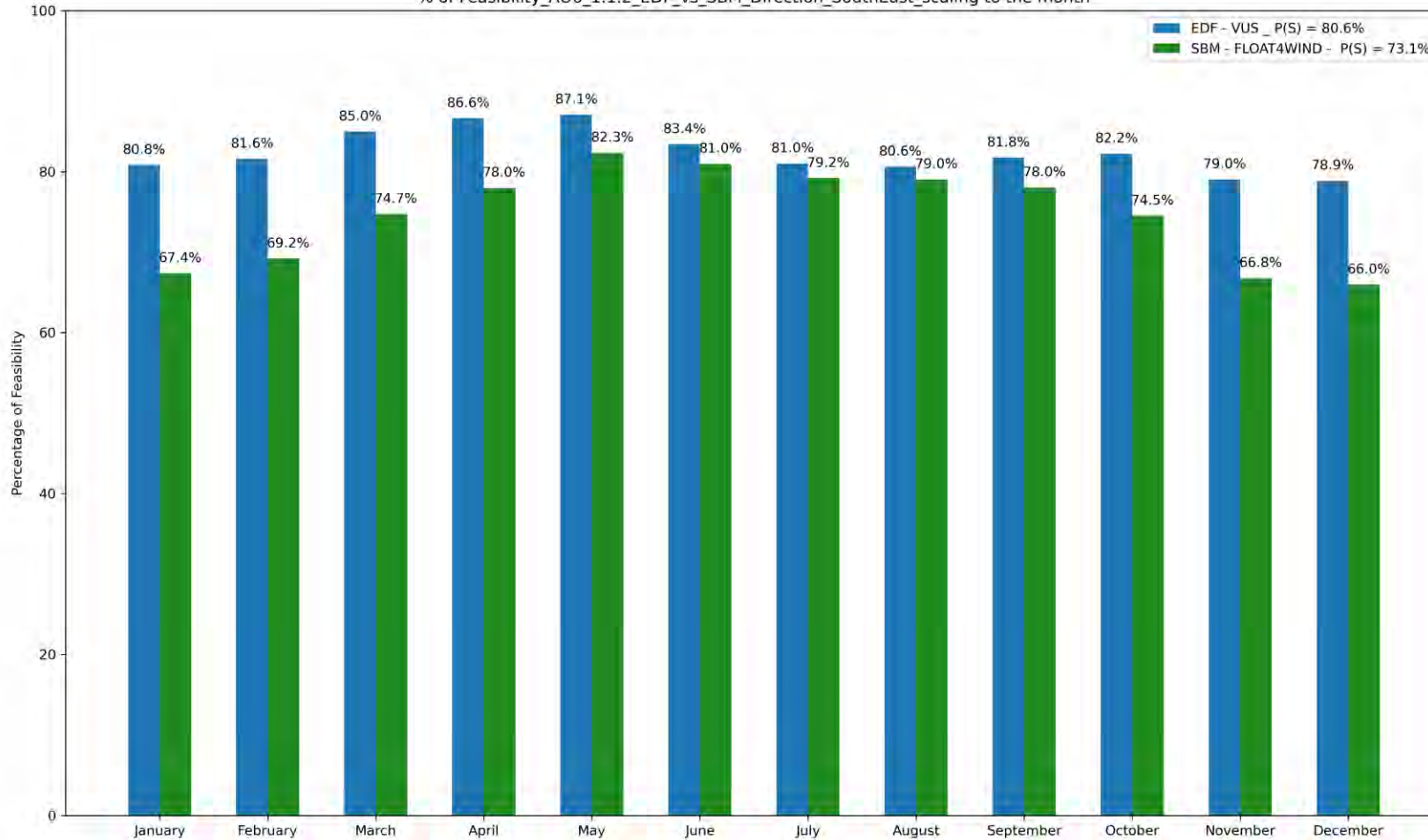

Case 1.1.2 : Package system installation with tugger line

/!\ operation duration not included in this operability analysis – default duration : 3h simulation

Percentage of Feasibility_AO5_1.1.2_EDF_vs_SBM_per_direction

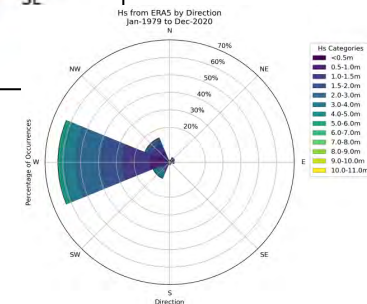
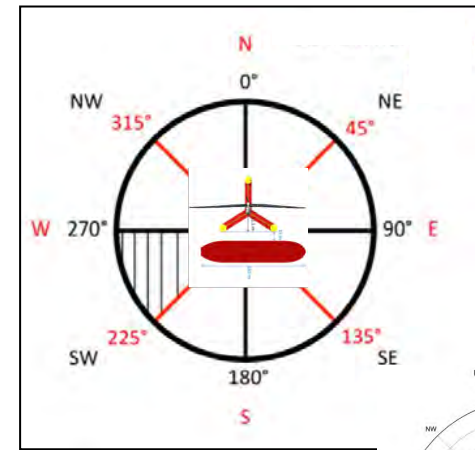
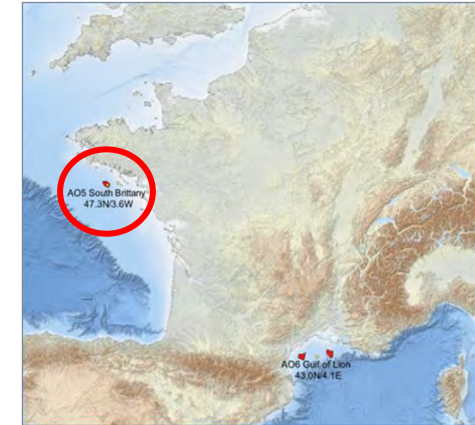
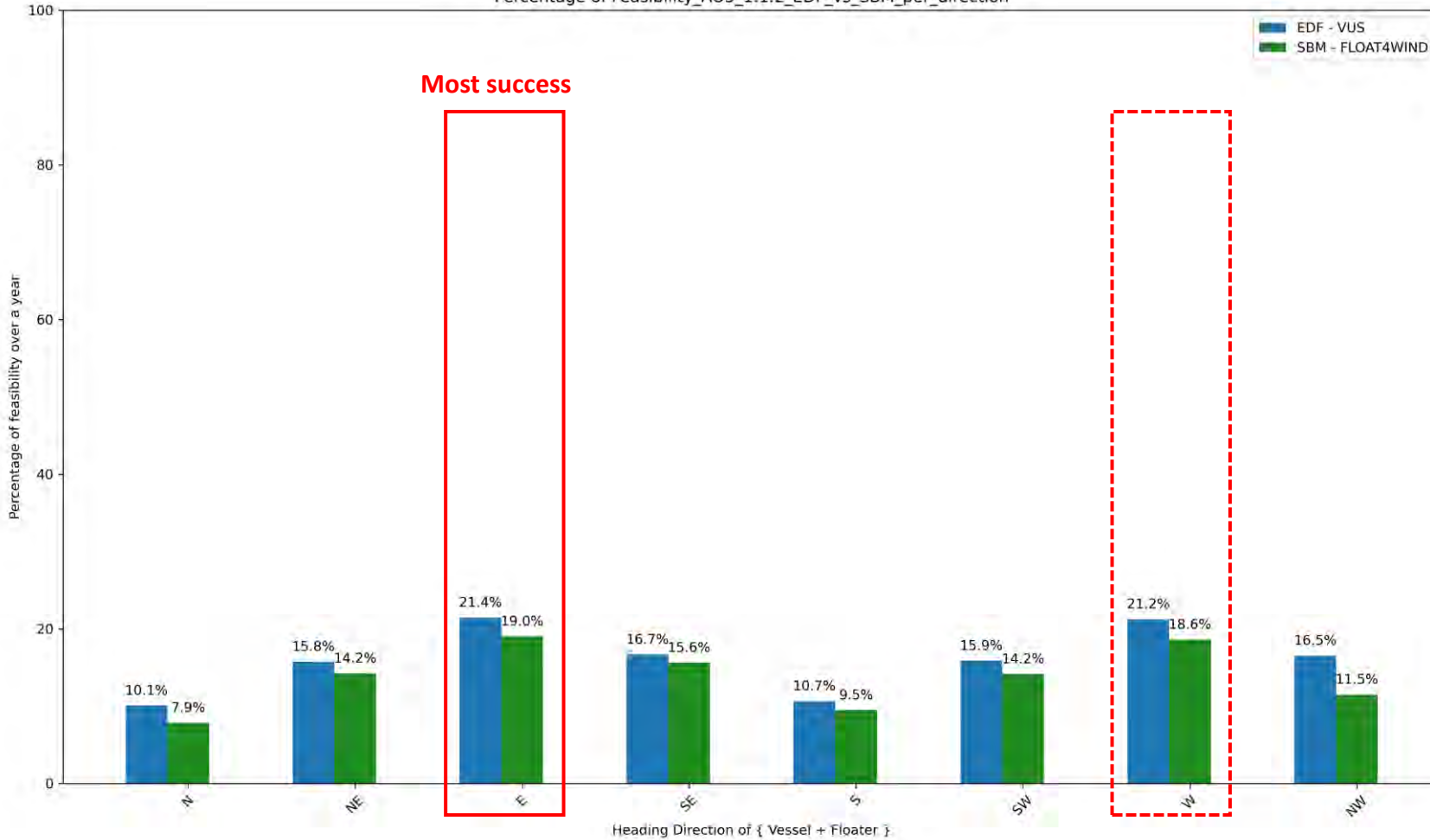

Case 1.1.2 : Package system installation with tugger line

/!\ operation duration not included in this operability analysis – default duration : 3h simulation

EDF - VUS

SBM - F4WTM

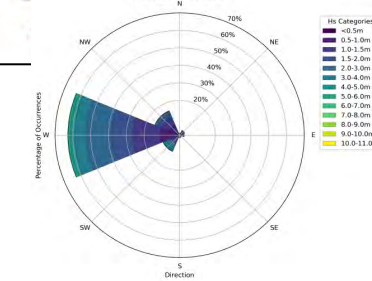
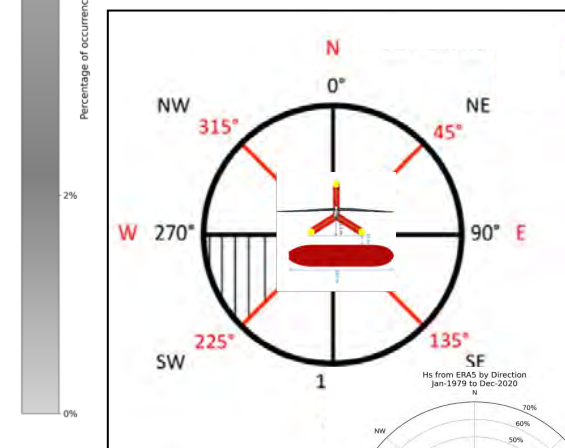
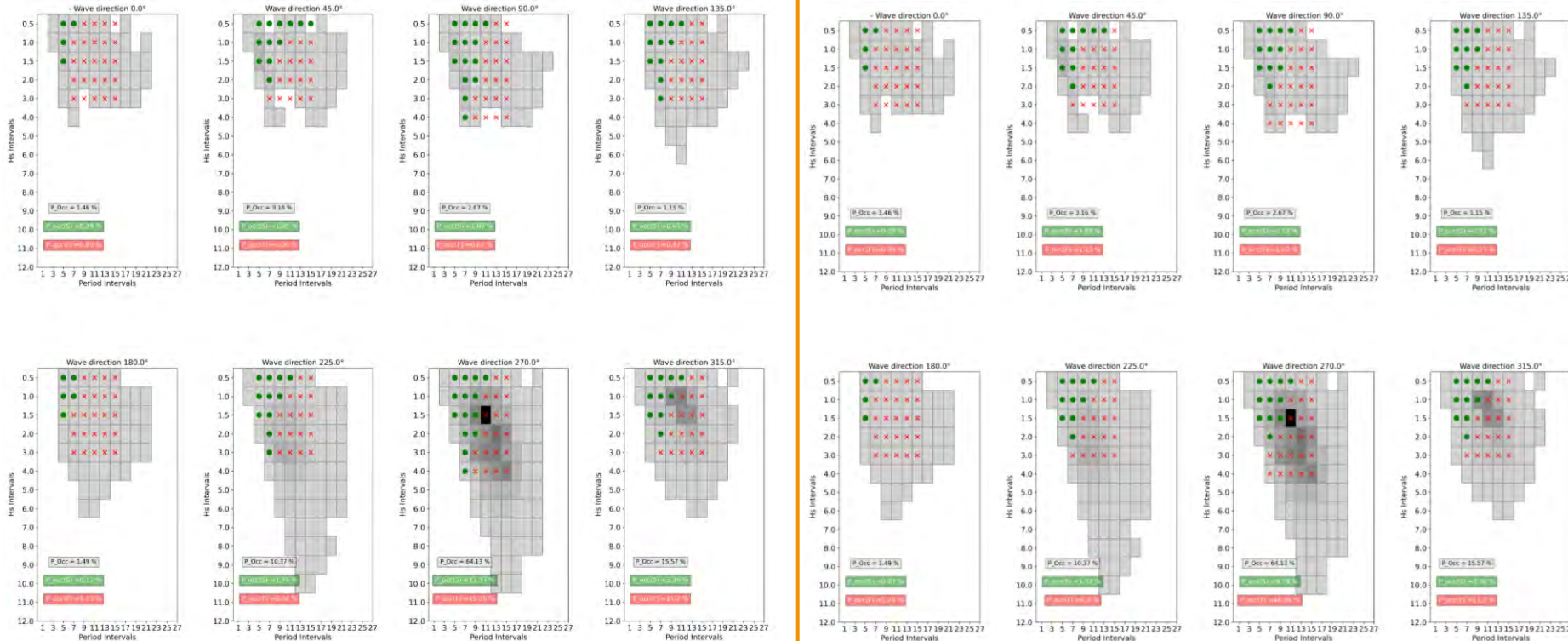

Case 1.1.2 : Package system installation with tugger line

/!\ operation duration not included in this operability analysis – default duration : 3h simulation

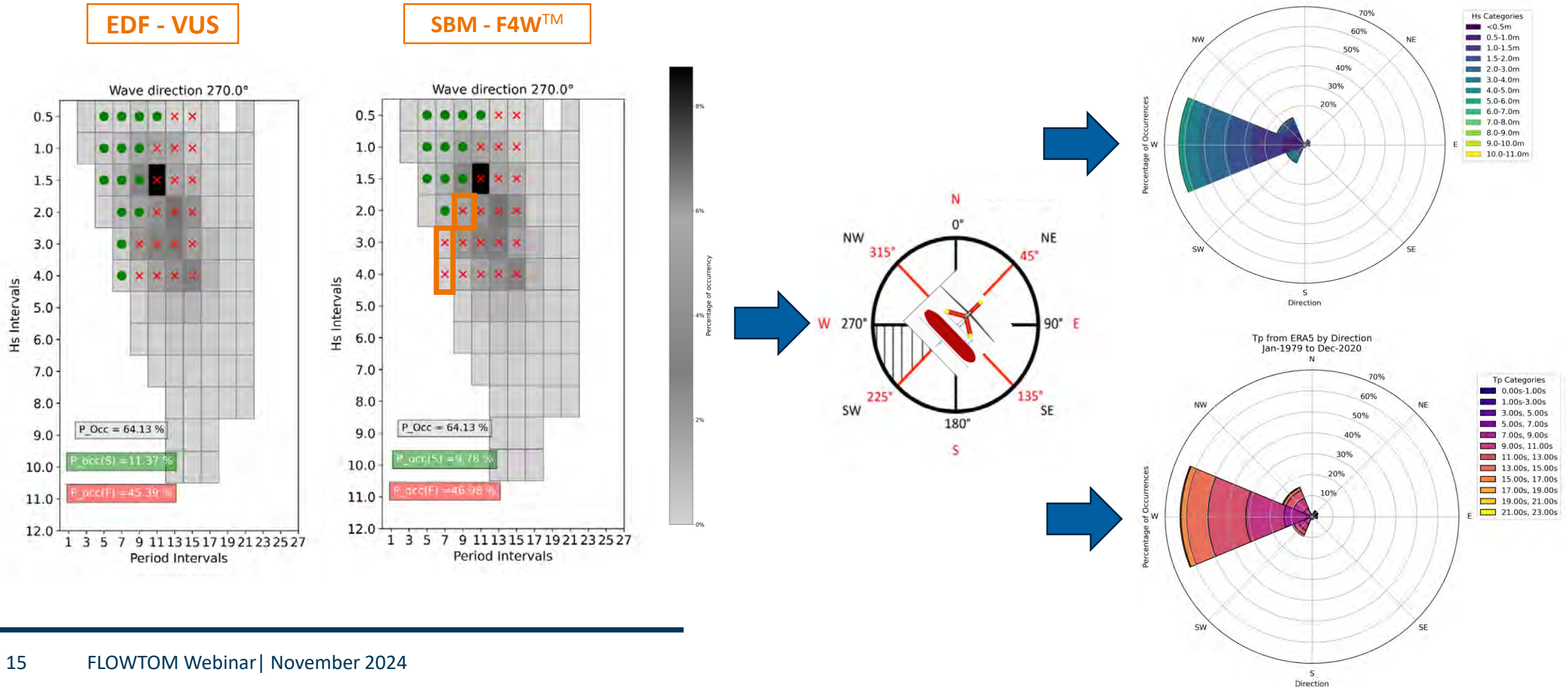

Case 1.1.2 : Package system installation with tugger line

/!\ operation duration not included in this operability analysis – default duration : 3h simulation

% of Feasibility_AO5_1.1.2_EDF_vs_SBM_Direction_East_scaling to the month

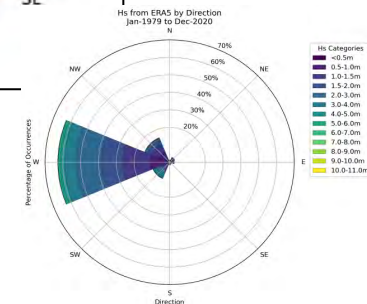
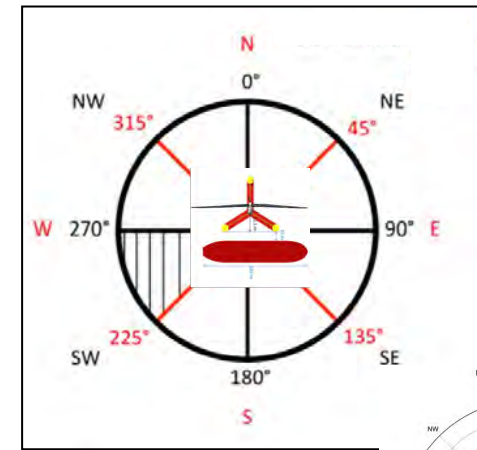
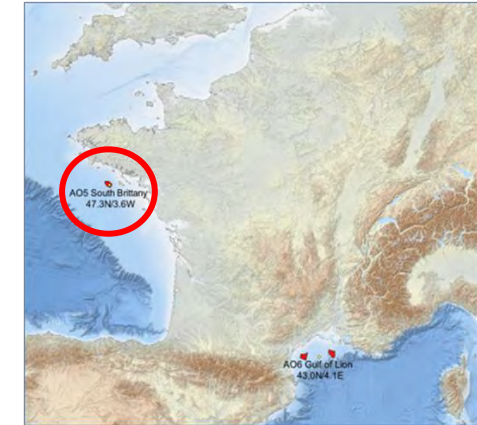
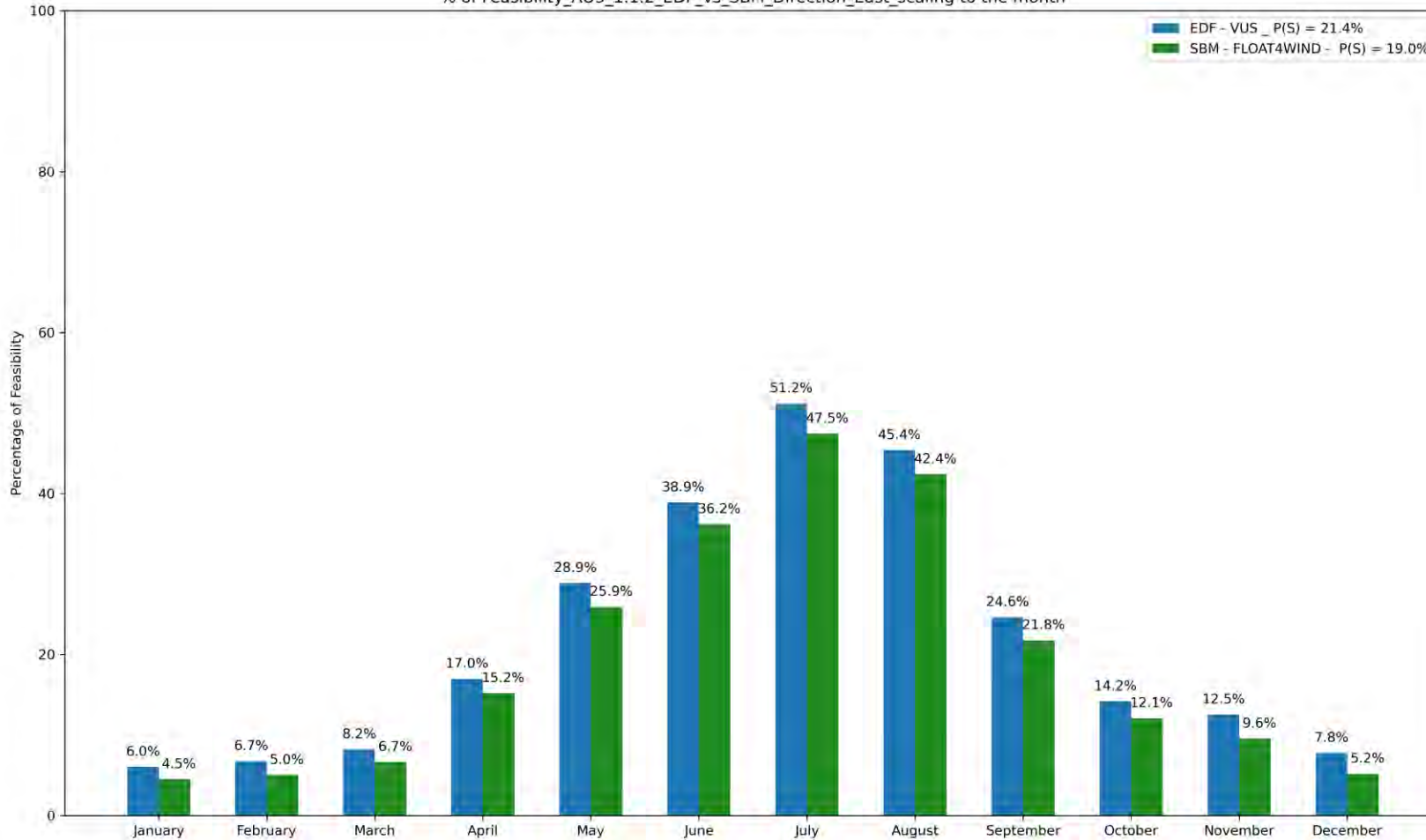

Case 1.1.2 : Package system installation with tugger line

Global rate of success *(without operation duration consideration)*

- Higher rate of success in Mediterranean sea conditions (AO6) due to the wave period
- Optimized weather window in summer (June/July/Aug) in South Brittany (AO5), spring/summer in Mediterranean sea (AO6)

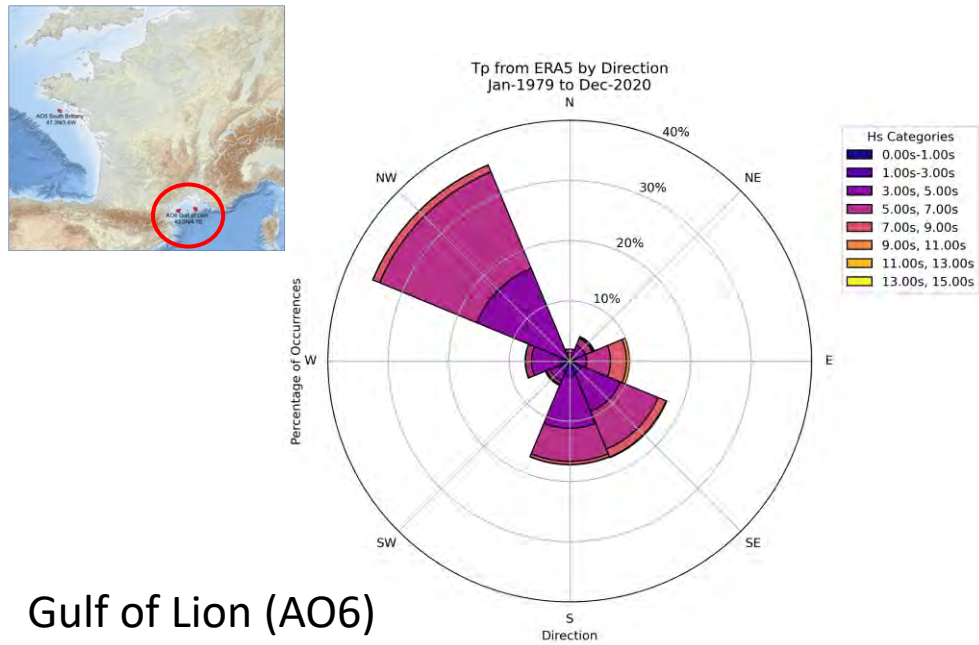

Gulf of Lion (AO6)

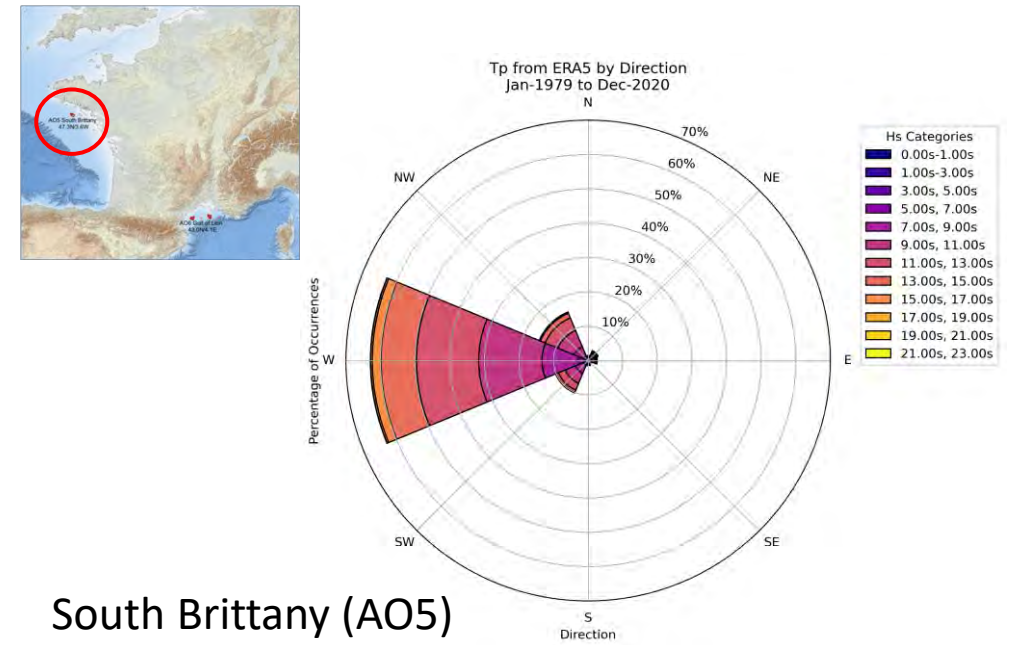

South Brittany (AO5)