



**Deliverable7.1: Requirements and
criteria for the design and planning of
ocean energy farms**

Tecnalia Research & Innovation

University College Cork

Iberdrola

WavEC

France Energy Marine

University of Exeter

DEME Blue Energy

University of Edinburgh

Vattenfall



This project has received funding from the European Union's Seventh Programme for research, technological development and demonstration under grant agreement No 608597

D7.1: Requirements and criteria for the design and planning of ocean energy farms

Project: DTOcean - Optimal Design Tools for Ocean Energy Arrays

Code: DTO_WP7_ECD_D7.1

	Name	Date
Prepared	Work Package 7	13/04/2015
Checked	Work Package 1	20/04/2015
Approved	Project Coordinator	27/04/2015

The research leading to these results has received funding from the European Community's Seventh Framework Programme under grant agreement No. 608597 (DTOcean).

No part of this publication may be reproduced, stored in a retrieval system, or transmitted in any form – electronic, mechanical, photocopy or otherwise without the express permission of the copyright holders.

This report is distributed subject to the condition that it shall not, by way of trade or otherwise, be lent, re-sold, hired-out or otherwise circulated without the publishers prior consent in any form of binding or cover other than that in which it is published and without a similar condition including this condition being imposed on the subsequent purchaser.

DOCUMENT CHANGES RECORD			
<i>Edit./Rev.</i>	<i>Date</i>	<i>Chapters</i>	<i>Reason for change</i>
A/0	24/10/2014	All	Update Table of Contents

Abstract

This Deliverable D7.1 reviews existing approaches and methodologies for the analysis of ocean energy arrays with a clear focus on the results and conclusions provided by previous experiences. The key outcome is the definition of quantifiable and qualitative metrics for economic viability, reliability and environmental impact which have been adopted in the global set of tools developed within the project DTOcean.

The needs of the industry, the recommendations of the Advisory Board and a literature review about the current approaches allowed the achievement of the main objective of this task consisting of the definition of the set of conditions (physical, economic and environmental) and design criteria (cost of energy COE, reliability index, energy yield and performances, etc.) for ocean energy arrays that will determine the drivers for the comparison of different alternatives. In particular, the needs of the industry have also been analysed and conveyed into the definition of the key requirements and variables for the definition of a decision tool. The most important technical parameters defined for the scenarios have been characterised by quantifiable variables (e.g. distance to shore, distance to port, power capacity of the grid, area of the sea surface available for deployment etc.), or suitable proxy, so as to allow their direct introduction into the design tool and they are herein reported as identified in Deliverable 1.1 – “Detailed deployment scenarios for wave and tidal energy converters” [1]. Since the economic framework represents an ideal method to evaluate and weigh the importance of different technical decisions, the levelised cost of energy (LCOE) was defined as the major economic quantifiable parameter; similarly reliability indicators and environmental impact factors have been identified and herein described.

TABLE OF CONTENTS

<i>Chapter</i>	<i>Description</i>	<i>Page</i>
1	INTRODUCTION	9
2	APPROACHES AND DRIVERS FOR COMPARING ALTERNATIVES OF ARRAY CONFIGURATIONS	11
2.1	PHYSICAL, ECONOMIC AND ENVIRONMENTAL CONDITIONS	12
2.1.1	Physical, economic conditions	12
2.1.2	Environmental conditions	17
2.2	DESIGN CRITERIA: ECONOMICAL, ENVIRONMENTAL AND RELIABILITY METRICS AND INDICATORS	17
2.2.1	Economic metrics and indicators	17
2.2.2	Environmental metrics and indicators	22
2.2.3	Reliability metrics and indicators	26
2.3	NEEDS OF THE INDUSTRY	28
2.3.1	Planning and Assessment Tools	28
2.3.2	Device Performance Standardisation	30
2.3.3	Uncertainty Analysis	32
2.3.4	Consultation	32
3	CHARACTERIZATION OF SCENARIOS DEFINED IN WP1	33
3.1	VALIDATION CASE 1 (WAVE): NORTH WEST LEWIS	35
3.2	VALIDATION CASE 2 (TIDAL): FAIR HEAD TIDAL	36
3.3	VALIDATION CASE 3 (WAVE): AEGIR SHETLAND WAVE FARM	37
3.4	VALIDATION CASE 4 (WAVE): WESTWAVE	38
3.5	VALIDATION CASE 5 (TIDAL): SOUND OF ISLAY	38
4	THEMATIC INDICATORS FOR EVALUATING MRE ARRAYS CONFIGURATIONS	40
4.1	ECONOMIC INDICATORS	40
4.1.1	Annual Energy Production (AEP)	40
4.1.2	Capital Expenditures (CAPEX)	41
4.1.3	Operational Expenditures (OPEX)	41
4.2	ENVIRONMENTAL INDICATORS	41
4.2.1	Receptors: environmental compartments/parameters	42

TABLE OF CONTENTS

<i>Chapter</i>	<i>Description</i>	<i>Page</i>
4.2.2	Stressors: environmental functions	43
4.3	RELIABILITY INDICATORS.....	47
5	CONCLUSIONS.....	50
6	REFERENCES.....	51
7	ACRONYMS.....	57

TABLES INDEX

<i>Description</i>	<i>Page</i>
Table 2-1: Drivers for the Wave Energy Scenarios (Figure 14 from [5])	13
Table 2-2: Drivers for the Tidal Stream Energy Scenarios (Figure 14 from [5])	14
Table 2-3: summary of opportunities (waves) for reducing costs, according to [6].....	15
Table 2-4: summary of opportunities (tidal) for reducing costs, according to [6].....	16
Table 2-5 : Average investment costs per installed MW related to offshore wind farms in Horns Rev and Nysted. (source [10])	19
Table 2-6 : CAPEX and OPEX Costs for tidal and wave projects (from [5]).	20
Table 2-7: Criteria for assessing the probability of impact on marine life from pressures associated with offshore wind farms.....	23
Table 2-8: Example of a computation method of the environmental impact total score, applied to offshore wind farm [28] 24	
Table 2-9: List of European MRE projects for which information about the environmental impact assessment is available [37]–[39].	25
Table 2-10: Reliability assessment methods considered for MRE devices (adapted from [50])	26
Table 3-1: Specific Scope parameters – Scenario in DTOcean Tool (as reported in Table 1 in D1.1 [1]of DTOcean Project)....	34
Table 4-1: Presentation of the environmental functions designed to assess the stressors intensity	46
Table 4-2: Reliability indicators produced by the RAM	48

FIGURES INDEX

<i>Description</i>	<i>Page</i>
Figure 1-1. Workflow of DTOcean as depicted in [2] (taken from Figure 7 of Section 1.3.1 of [2]).	10
Figure 2-1 : The cost of Wind Energy (from [10]).	18
Figure 3-1: Oyster Technology for Validation Case 1 (image from [68]).	36
Figure 3-2: MCT Tidal Turbines for Validation Case (image from [69]).	37
Figure 3-3: Pelamis P2 Technology for Validation Case 3 (image from [70]).	37
Figure 3-4: RM3 device design and dimensions, for Validation Case 4 (from [71]).	38
Figure 3-5: Andritz HS1000 tidal turbine for Validation Case 5 (image from [72]).	39
Figure 4-1. Main drivers used for the environmental impact assessment in the DTOcean tool	42
Figure 4-2: Summary of functions related to each WP.	44
Figure 4-3: Possible GUI representation of array and device hierarchies and method of presenting MTTFs (or TTFs), percentage reliability over time and RPNs at (top) system and (bottom) component levels	48

1 INTRODUCTION

The DTOcean project proposes the release of a set of tools driving the final user, i.e. designers and marine renewable energy (MRE) project developers, in the decision-making process among different alternatives for the design of the first generation of MRE arrays. The set of tools covers the overall spectrum of design tasks, starting with hydrodynamic performance assessment, to the analysis of the electrical subsystem, moorings and foundations, and concluding with installation, operations and maintenance and their logistics. The tools consist of open-source software, divided into modules, each of them covering a different topic among those afore mentioned. The objective of the set of tools is to provide a solution for the design of MRE arrays (essentially wave and tidal), searching for an optimal balance between the needs of the user, the viability of the project and other impacts. The set of tools is accompanied by a database which contains long-standing environmental data; mechanical, economical and reliability characteristics of devices/components/subcomponents; and equipment, vessels and ports required for installation and maintenance logistics. The data contained in the database might be used as reference data for the user.

The overall project is distributed into nine work packages. The administrative work packages, WP8 and WP9, are in charge of communication and dissemination, and project coordination, respectively. The remit of WP1 is the formulation of the scenarios and validation cases, and the structuring of the database. WP2 will provide the module of hydrodynamic tools; WP3 the electrical subsystem design; WP4 the moorings and foundation; WP5 installation and logistics requirements; and finally WP6 will develop the Operation and Maintenance planning. WP7 is in charge of collecting all the modules which form the global set of tools and collecting the information from them which is required for elaborating the economic, reliability and environmental impact metrics.

In the DTOcean tool, *array designs and solutions for MRE devices will be benchmarked with regard to their economics, reliability and environmental impact*, according to what is included description of work (DoW) of DTOcean [2], Section 1.2.4 of Part B. The procedure consists in the definition of quantitative criteria, such as for the evaluation of the economics and reliability of the systems, as well as qualitative criteria as in the case of the evaluation of the environmental impact.

Similarly in Section 1.2.5, the need for some research indicators is expressly mentioned in order to rate environmental, economic and reliability impact, which will be evaluated throughout all the technical WPs (*WP2, WP3, WP4, WP5, and WP6*) *in order to achieve a global assessment in the core of the tool*.

Figure 1-1 (freely taken from Figure 7 of Section 1.3.1 of Part B of DoW) shows how the themes (economics, reliability and environmental impact) are transversal to all the technical WPs.

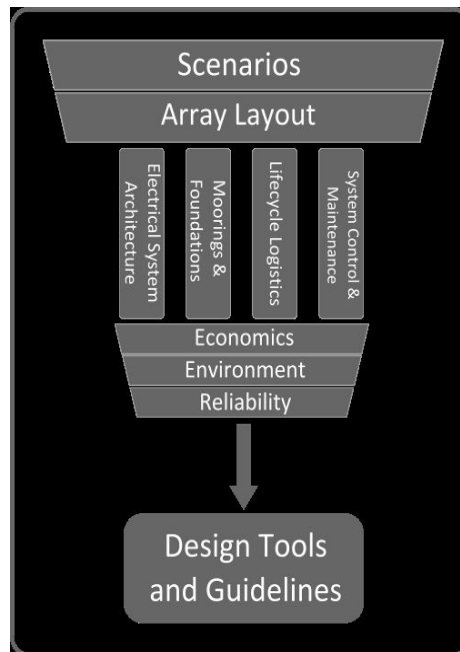

Figure 1-1. Workflow of DTOcean as depicted in [2] (taken from Figure 7 of Section 1.3.1 of [2]).

This deliverable, then, is intrinsic to the final targets of the project, in which the design of an MRE array will be evaluated in terms of economic viability, reliability and environmental impact.

The deliverable will be structured as follows:

- Section 2 is dedicated to a general state of the art review of completed or ongoing projects and scientific literature which have been already identified for the evaluation of similar technologies to MRE arrays. It also addresses other key drivers, such as industry needs.
- Section 3 reviews the quantifiable variables chosen as part of the database to be developed by WP1, explaining why some variables have been chosen instead of others, and which of them can be replaced in case the data are not available, or not provided at the level of detail required. A summary of the selected scenarios and validation cases is also included.
- Section 4 proposes the methodologies and metrics for evaluating the economic viability, reliability and environmental assessment within the framework of DTOcean.
- Section 5 summaries the decisions taken during the first 18 months of the project, with respect to the topics covered in this document.

2 APPROACHES AND DRIVERS FOR COMPARING ALTERNATIVES OF ARRAY CONFIGURATIONS

DTOcean aims to offer the future user a set of tools for accelerating the decision making process for the design of ocean (wave and tidal) energy arrays.

The global set of tools must be multi-objective according to the description of work [2], and this has been interpreted not only as if the final release of the tools should provide information in terms of economic viability of the project, or reliability of the system or environmental impact, but also mainly providing answers in terms of array design, electrical, mooring and foundation components and layout, installation, operation and maintenance plans with related logistics satisfying the user's needs.

In this regard, it was necessary to:

- Define a set conditions (physical, technology-related, environmental and economic) having a major impact on at least one of the three themes investigated in DTOcean. Significant existing literature is available for identifying physical aspects influencing the economic viability of these technologies in general. A consensus is observed (see for example [3]) that the costs of electricity from renewable resources are function of many factors: the type of energy source and its availability, the technology (type of device that harnesses the energy), choice of components and efficiency of the plant, site location (also for logistic requirements), and the strategies for installation and operations.
- Define the metrics necessary to rank the feasible solutions under a defined criterion. When possible, this criterion should be quantifiable: this is the case of the economic theme; in other cases, however, the lack of knowledge in the sector and/or the absence of agreement among different methods in the scientific community can prevent the use of quantifiable indicators. This may be sometimes the case of environmental theme if the indicators can only be defined at a qualitative level. Additionally, reliability needs special consideration as it directly influences the operations and the maintenance requirements. For this application a quantitative approach is necessary; however in order to estimate the overall reliability of the system a qualitative indicator might be more effective for comparing alternative solutions.

The approach above is similar to that used for offshore wind projects. It is clear that several options are available to designers and stakeholders, so that choices need to be taken at different stages of the project development: pre-lease, pre-consent and pre-construction, (Chapter 4 of [4]). Dependent on the outcome of each of these stages and remaining risks identified, the decision is made to proceed (or not) with the development and to gather more detailed information on the site and business case.

The following section follows the same flowchart:

- In Section 2.1, the set of physical and environmental conditions influencing the economics (and therefore the viability) of a MRE array design project are investigated, making reference to already existing studies of projects;
- In Section 2.2, a broad survey of scientific literature of past and ongoing projects about the design criteria (economics, reliability and environmental impact) for arrays is included. In each sub-section, the lesson learnt from the offshore wind sector is included, and then a review about metrics used in the MRE field is described.
- In Section 2.3, the needs of the industry driving the final choices taken in the subsequent development of the DTOcean tools are discussed.

2.1 PHYSICAL, ECONOMIC AND ENVIRONMENTAL CONDITIONS

2.1.1 *Physical, economic conditions*

The most important parameters for project development are the cost - meaning the overall cost including development, turbines, construction, operations, maintenance, etc... - and the revenue over the project lifetime. The costs are often split into capital costs (CAPEX) and operational costs (OPEX). Investigation into the external conditions influencing the economic viability and techno-economic assessment of wave and tidal energy devices and arrays remains cutting-edge. An example is [5], in which the Department of Energy and Climate Change and the Scottish Government have commissioned a project in order to assess, besides other analyses, the likely downwards evolution of generation cost for wave, tidal stream and tidal range generation costs on future demonstration and deployment to 2020, 2035 and 2050. The methodology was to identify key cost drivers influencing the costs under different scenarios and the extent to which each drives the costs. Table 2-1 and Table 2-2 are examples of these drivers. In studies like these, the importance of learning rates is highlighted when applied to deployment.

	Wave
Demonstration of first 10MW farm operational. (Assuming total global deployment of 50MW)	2014 (50MW)
Average 10MW commercial farm operational after 50MW installed. (Assuming total global deployment of 160MW)	2016 (160MW)
Distance from shore	3-7km
Water depth	>30m (offshore) <30m (near shore)
Mean power (energy density)	22-35KW/m
Mean Base Case capacity factor	28-42%
Typical project life	20 years
Typical construction period	2 years

Table 2-1: Drivers for the Wave Energy Scenarios (Figure 14 from [5])

Other EU-funded projects have incidentally dealt with the definition of factors which may affect the economic and socio-economic impacts of an array of MRE devices. For example, the SI OCEAN project's main goal was to deliver a common strategy for ensuring maximal wave and tidal energy installed capacity by 2020, paving the way for exponential market growth in the 2030 and 2050 timeframes.

In particular, deliverable D3.2 of the SI OCEAN project [6] depicts a very general overview about cost of energy and cost reduction opportunities. More generally, that deliverable shows that several variables (not only physical and environmental, but also logistical and operational) affect costs.

Table 2-3 and Table 2-4, again taken from [6] illustrate some of the cost reduction opportunities for producing more reliable and cheaper designs of the first generation of ocean energy arrays.

	Tidal stream shallow	Tidal stream deep
Demonstration of first 10MW farm operational. (Assuming one developer per 10MW and at global deployment specified)	2015 (20MW)	2018 (15MW)
10MW commercial farm operational after 50MW installed. (Assuming one developer per 10MW and at global deployment specified)	2017 (100MW)	2020 (60MW)
Water depth	<50m	>50m
Mean power (energy density)	3m/s	3.2m/s
Mean Base Case capacity factor	35%	37%
Typical project life	20 years	20 years
Typical construction period	3 years	2 years

Table 2-2: Drivers for the Tidal Stream Energy Scenarios (Figure 14 from [5])

Studies outside of Europe have also defined some scenarios for the development of wave and tidal projects. For example, in [7] and [8] the economic viability of wave energy power plant projects in Canada and Southern California were assessed using different technologies (AquaBuoy, Pelamis, WaveDragon). Clearly, the level of uncertainties in these models is still extremely high; however they offered a good illustration of the physical factors influencing costs, and also offered an insight into regulatory issues as a critical component of the project development decision criteria (being often the deciding factor of whether or a not a project is pursued) and often being related to environmental aspects, as well. The impacts of several physical phenomena have been investigated either quantitatively or qualitatively. For instance, the marine environment may highly influence the maintenance of the devices, being seawater corrosive and the variable loads and shock forces affecting the accumulated damage of OECs: this is a case in which the three cross-cutting themes are coupled one another making the problem even more complex.

The socio-economic impact of MRE devices or arrays has also been the object of advanced research in the last years, considering the effects on co-existing sea-users such as fisheries or surfing communities [6].

Summary of opportunities –wave

	Capex reduction	Yield improvement	Opex reduction
Structure & prime mover	Material optimisation Upscaling of devices Batch and serial production Reduced over-engineering Regional manufacturing	Geometry optimisation Optimisation of array layout	
Power take-off	Improved power electronics Improved hydraulic system Alternative / improved PTOs	Improved control systems and algorithms Improved hydraulic system Improvements in metocean forecasting Drive train optimisation Improved power electronics Array yield optimisation	Modular subsystems
Foundations & moorings	Improved moorings Improved foundations Improved piling techniques Cost effective anchors for all sea bed conditions.	Deep water installation techniques	
Connection	Off-shore umbilical / Wet-mate connectors Subsea hubs Array electrical system optimisation (transformers etc.) Offshore grid optimisation	Optimised subsea transmission to reduce losses	Improved connection and disconnection techniques
Installation	Specialist vessels Modularisation of subsystems Improvements in metocean forecasting Fast deployment and other economic installation methods Subsea and seabed drilling techniques Improved ROV and autonomous vehicles		
O&M		Improved availability through: Intelligent predictive maintenance Techniques to reduce weather dependency	Increased reliability Modular components. Simpler access Specialist vessels For offshore O&M strategy

Summary of opportunities –tidal

	Capex reduction	Yield improvement	Opex reduction
Structure & prime mover	Material optimisation Upscaling of devices Batch and serial production Reduced over-engineering Multiple rotor platforms Regional manufacturing	Optimisation of siting to maximise yield Micro-siting techniques Improved yaw and pitch mechanisms Hydrodynamically optimised structures Upscaling length of blades	Multiple rotor platforms
Power take-off	New drive train configurations Alternative and improved PTOs	Direct drive Improved hydraulic actuation systems Improved control systems and algorithms Array yield optimisation	Modular subsystems
Foundations & moorings	Improved subsea/seabed drilling Specialist vessels Improved piling and fixing techniques Improved mooring techniques (floating devices)	Floating or neutrally buoyant devices accessing high energy flows Hydrodynamically optimised foundations/platforms	Specialist vessels
Connection	Off-shore umbilical / Wet-mate connectors Subsea hubs Array electrical system optimisation (transformers etc.)		Improved connection and disconnection techniques
Installation	Specialist vessels Improvements in metocean forecasting Modularisation of components Improved ROV and autonomous vehicles		
O&M		Improved availability through: Intelligent predictive maintenance Techniques to reduce weather dependency	Intelligent predictive maintenance Increased reliability Modular components. Simpler access Specialist vessels Intelligent predictive maintenance Improved ROV and autonomous vehicles

Table 2-4: summary of opportunities (tidal) for reducing costs, according to [6]

2.1.2 *Environmental conditions*

Environmental conditions are, in the first instance, important to obtain planning consents. These conditions include proximity to strategic protected area's (SPA's), presence of protected birds & mammals, benthic, fish, fisheries, etc. Specific surveys are required to identify these conditions (baseline) and what the impact of the marine energy project will be on these conditions, i.e. the so-called Environmental Impact Assessment (EIA), both off and onshore. This was also discussed in deliverable D3.2 of the SI OCEAN project [6]. Typically, in European waters, most of the ocean energy project developments will require environmental monitoring during construction and operation phases showing once again, the increasing importance of evaluating the effects on marine ecosystems.

A significant positive environmental impact of MRE arrays is reduction of carbon emissions respective to conventional energy generation technologies (see for example [9]) , which may also have a positive impact on the cost of energy, should carbon taxation become more aggressive in the future.

2.2 **DESIGN CRITERIA: Economical, Environmental and Reliability metrics and indicators**

The main source of existing information for the ocean energy sector is provided by the offshore wind industry. Although there are significant differences between the two industries, the greater level of development of wind energy, similar budget conditions and similar environmental challenges (in the case of offshore wind) make the lessons learnt from wind sector particularly relevant for the development of the ocean energy sector. This is the reason why the selection process for suitable potential indicators for the themes within the DTOcean tools includes a survey of what has so far been done in the wind energy industry, and then, when possible, application to the MRE devices sector .

2.2.1 *Economic metrics and indicators*

Indicators to estimate the economic impact of wind energy consider definition of parameters which take into account several aspects and stages of the energy production process.

An EWEA report [10] illustrates the key elements that determine the basic costs of wind energy which are shown in detail below. Namely:

- Upfront investment costs;
- The costs of wind turbine installation;
- The cost of capital, i.e. the discount rate;
- Operation and maintenance (O&M) costs;
- Other project development and planning costs;
- Turbine lifetime;
- Electricity production, the resource base and energy losses.

All these components of costs are represented in Figure 2-1. When studying the economic impact of wind farms, different metrics or units can be used for each component, in order to focus the attention onto the most sensitive variable. For example, the investment cost of the wind farm can be expressed in terms of capacity installed (addition of upfront/capital costs plus variable costs) while

when incorporating the energy production it is of more interest to express the cost of wind energy per kWh produced.

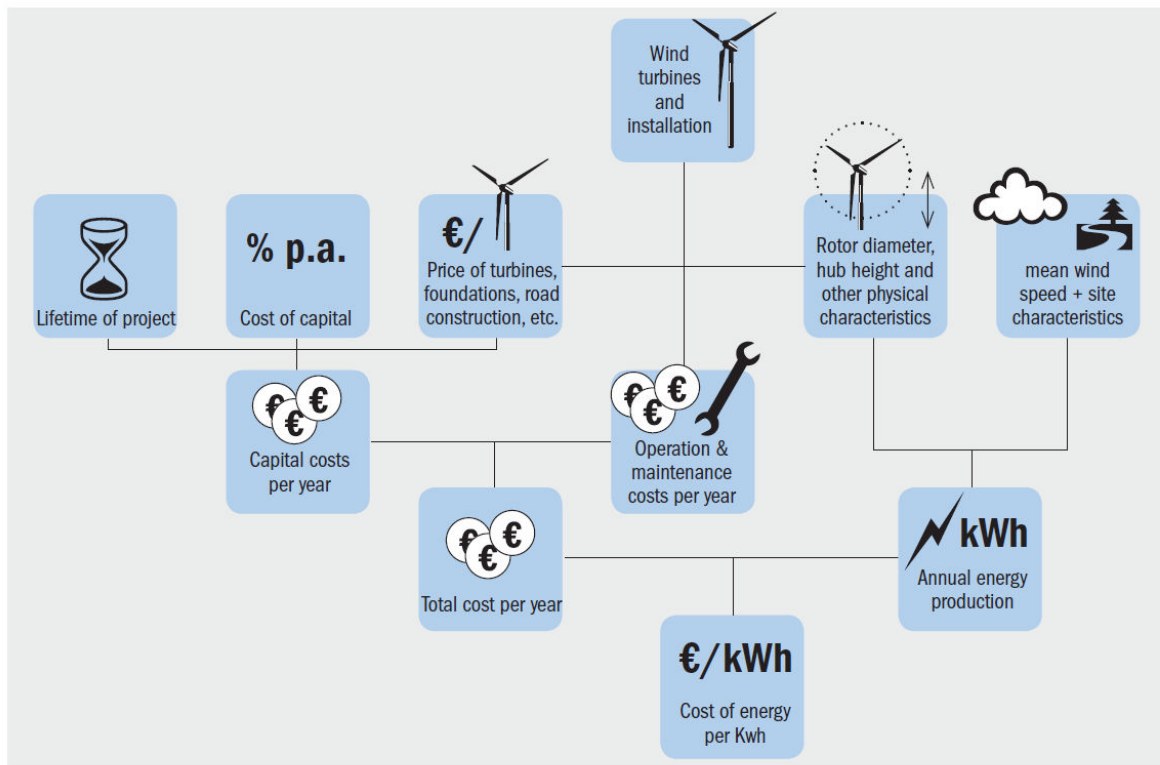

Figure 2-1 : The cost of Wind Energy (from [10]).

When evaluating the influence of installation costs, one relevant economic indicator is the cost per installed capacity as aforesaid, an example of which can be seen in Table 2-5. It is true that this parameter is very easy to interpret, however its application to the MRE sector can lead to confusion in a sector where the typical capacity factor of the plant is not established yet.

An overview of different available economic indicators used for renewable energy and how these should be applied was published by NREL in 1995 [11].

In the MRE sector, different indicators might be used for wave and tidal devices. For WECs, it could be useful to define the euros/tonnes of steel, since the main driver for wave energy farms is the device investment, as the devices themselves are bulky and usually made of steel. This metric is even

less comprehensive than the cost per MW. It is not representative for tidal energy and therefore it is not suitable for ocean energy in general.

	INVESTMENTS 1000 €/MW	SHARE %
Turbines ex works, including transport and erection	815	49
Transformer station and main cable to coast	270	16
Internal grid between turbines	85	5
Foundations	350	21
Design and project management	100	6
Environmental analysis	50	3
Miscellaneous	10	<1
TOTAL	1,680	~100

Table 2-5 : Average investment costs per installed MW related to offshore wind farms in Horns Rev and Nysted. (source [10])

A more global economic indicator should be defined when a wider perspective on the cost is needed in order to include other financial parameters and compare different alternatives. Indeed, the viability of onshore wind energy projects highly depends on relatively low operating costs, while traditional sources of energy, such as coal and natural gas fuelled generators, generally may rely on lower capital costs.

For these reasons, it would be important to define a metric inclusive of:

- Capital Expenditure - CAPEX:
- Operational Expenditure - OPEX
- Revenue – Annual Energy Production AEP

Each of these three components may be represented by an isolated indicator. CAPEX is usually shown as relative to the nameplate capacity (MW), while OPEX, due to lack of empirical data, can be presented similarly to CAPEX as relative to nameplate capacity, as a percentage of the CAPEX itself, or as a function of the energy production. For example, in the case of tidal energy, different units are used for values of OPEX and CAPEX (for instance, see Table 2-6 , taken from [5]. Also AEP can be expressed using different metrics: some authors ([12]) have used different metrics, such as the absorbed Energy per Characteristic Mass [kWh/kg], or the Absorbed Energy per surface Area [kWh/m²] or per RMS of PTO force [kWh/N] when comparing the annual production among different technologies differing for mass, pierced area or PTO force.

Technology	Pre-demonstration project (low - high)	Demonstration project (costs for developer's first 10MW project) (low - high)	Commercial project costs for developer's 10MW project after 50MW deployed (low - high)
Wave			
Capex/MW	£7.3m (£6.1m - £8.6m)	£4.9m (£4.1m - £5.7m)	£3.4m (£2.8m - £3.9m)
Opex/MW/year	£0.63m (£0.52m - £0.74m)	£0.29m (£0.24m - £0.35m)	£0.2m (£0.17m - £0.24m)
Net load factor ³	31%	33%	34%
Tidal Range			
Capex/MW	n/a	n/a	£2.7m (£2m - £3.2m)
Opex/MW/year	n/a	n/a	£0.03m (£0.03m - £0.04m)
Net load factor	n/a	n/a	20%

Table 2-6 : CAPEX and OPEX Costs for tidal and wave projects (from [5]).

The typical approach for evaluating the overall capital investment is to calculate either the Net Present Value (NPV) or the Internal Rate of Return (IRR) [13]. To calculate the NPV, all revenues and costs (e.g. cashflow CF) are estimated for the life of the project. These are all present valued to time zero (the start date of the project), discounted by the weighted average cost of capital (WACC). The present value of the expected capital costs and operating expenses are subtracted from the present value of expected revenues. If the NPV > 0, the project is expected to be profitable, based on forecasted numbers and probabilities, over and above the financing costs.

$$Net\ Present\ Value = \sum_{i=0}^n \frac{CF_i}{(1 + WACC)^i}$$

The internal rate of return is related to the NPV. Rather than discounting the cash flows at the weighted average cost of capital to solve for the NPV, the NPV is assumed to be \$0 (the breakeven scenario). The discount rate that equates the present value of inflows with outflows, so that the NPV will be \$0, is the internal rate of return. If the IRR > WACC, the project is expected to be profitable, again based on forecasted numbers.

$$\$0 = \sum_{i=0}^n \frac{CF_i}{(1 + IRR)^i}$$

NPV and other financial indicators like Internal Rate of Return, Discounted Pay-Back Period (DPBP) and Benefits/Costs ratios require a specification of revenue stream (i.e. information relative to the feed-in-tariff, the retail price of energy and availability of other mechanism support such as capital grant). They should account for taxes and financing options, which are dependent on the project characteristics, meaning they are less suitable for comparison of different technologies, and require unnecessary extra calculations for comparison of alternatives in a project.

For these reasons, in the wind sector

“... the standard industry practice is to calculate the levelized cost of energy (LCOE), a metric that seeks to calculate the average cost of power production per Megawatt-hour (MWh) of output over the full lifetime of a power plant. The LCOE includes both capital costs and operating costs, but may not include the cost of transmission upgrades, grid integration costs, and other costs that may be associated with the wind project. LCOE estimates rely on four key pieces of data: installed capital cost, annual operating expenses, annual energy production, and the ‘fixed charge rate.’” [14]

Despite not including each and every factor, the LCOE has been adopted as the standard metric for describing the impact of wind energy farms, both onshore and offshore. Other energy production systems have also recognized the LCOE as a standard economic indicator.

The accuracy of the LCOE is directly related to the method used for assessing the 3 main components of the LCOE equation, as shown below:

$$LCoE = \frac{PV(CAPEX) + PV(OPEX)}{PV(AEP)} \text{ (€/kWh)}.$$

The sources of information on costs come either from examples in the market – real components with costs provided by suppliers, or estimates based on past projects (including offshore wind energy and other marine sectors).

Most of the analyses for this field that has been conducted by NREL (see for example [15]) makes extensive use of LCOE as a control variable for performing parametric assessment studies on changes in variables affecting its four components.

LCOE is an indicator that is understandable for both developers and investors, as it is comparable to the market electricity selling price, and it requires fewer inputs than other indicators such as Net Present Value (NPV). Nevertheless, in the context of a project feasibility assessment, these other financial indicators can be readily computed by making use of the ingredients forming the LCOE calculation.

In literature there are several sources dealing with the problem of evaluating the economic assessment of ocean energy farms: in some cases they deal with the cost of wave energy [16], [17], [18], [19], [20], [21], [22], [23], only tidal [24], or more generally marine energy [25], [26].

2.2.2 Environmental metrics and indicators

Several approaches have been used for the environmental assessment of offshore wind energy devices (see for example [27], [28]). The effects of wind farms on the environment is still of extreme interest, often causing concerns in the technical community but also in public opinion. Some of the issues are typical of the wind industry sector, such as impacts between birds and the blades of wind turbines; however attention has increased in considering the possible impacts of noise and vibration generated by wind farms on the marine habitat: species ranging from whales to lobsters.

In [28], the identified approach for dealing with the problem consists in several stages:

Stage 1) consists of searches in scientific databases, or more generally over the internet, for reports produced by consultant agencies or governmental authorities in connection to monitoring programmes of existing offshore wind farms (OWFs);

Stage 2) requires screening for relevance in relation to the delineations of the study (main pressures and ecosystem components, as outlined below). In this case it is extremely important to differentiate between stressors and receptors. ([29], [30]):

- Stressors are those factors that may occur as ocean energy systems are being installed, operated, or decommissioned, as for example extraction of energy, acoustic effects or electromagnetic effects.
- Receptors are those elements of the marine environment such as birds, mammals, benthos, that may be affected by stressors.

The receptors and the stressors selected for the DTOcean tool are described later in Section 4 in this document.

Stage 3) is to distinguish between impacts occurring during the construction phase (when the main pressures included were; acoustic disturbances and increased sediment dispersal), and during the operational phase (for example, habitat gain, fisheries exclusion, acoustic disturbance, and electromagnetic fields). In general, spatial and temporal variation of the stressors' intensity (project

phases, the different methods of installation of the project components) and the sensitivity of the receptors (seasonal pattern, species migratory or avoidance behavior) increase the difficulty in properly evaluating the environmental impacts. Furthermore, impacts during the decommissioning phase of an offshore wind farm life cycle are very difficult to assess or evaluate because there is no experience/feedback and little research has hitherto been dedicated to evaluating this stage; most of times, decommissioning effects are assimilated as those from the construction phase.

An example of impact evaluation can be found in [28]: the probable impact on marine species was assessed—with respect to the following aspects; (i) temporal extent, (ii) spatial extent, and (iii) sensitivity of species within each ecosystem component, ranking each impact with scores from 1 to 3 (see Table 2-7).

Score	Spatial extent	Temporal extent	Sensitivity	Certainty
1 (low)	<100 m	During construction	Minor or no effects on the abundance and distribution of local species	Limited or no empirical documentation
2 (moderate)	<1000 m	Throughout operational phase	Effects on the abundance and distribution of local species, no effects on food web	Documentation available, but results of different studies may be contradictory
3 (high)	>1000 m	Permanent	Effects on the abundance and distribution of local species, effects on food web	Documentation available, relatively high agreement among studies

Table 2-7: Criteria for assessing the probability of impact on marine life from pressures associated with offshore wind farms.

In addition, the level of certainty in the assessment was evaluated based on how well the conclusions were supported by the peer-reviewed part of literature (such as the work in [27], for instance). Environmental indicators for impact are therefore expressed more qualitatively than quantitatively. A total sum of 3–4 indicated low overall impact, whereas a total sum of 5–6 indicated moderate overall impact. A total sum of 7–9 indicated high overall impact (see table 2-4).

The study also stressed that the topic does not necessarily need to be tackled from a negative perspective as there could be positive impact of wind turbines to take into account, for instance, to act as an artificial habitat (the “reef effect”) and so increase the diversity of species and biological productivity of windfarm locations. Further developments to the quantitative approach described above are found in [28] and [31]. In these works, the quantitative approach is applied to the computation of the final score and not to the evaluation of stressor intensity and receptor sensitivity that remains qualitative (see the example in Table 2-10).

Table 2. Synthesis of potential impact on marine life from main pressures during OWF construction. Values give scores for probable impact (1 = low, 2 = moderate, to 3 = high) in relation to each of the criteria spatial extent, temporal extent and sensitivity. ‘Total’ denotes their sum. ‘Certainty’ indicates the level of literature documentation to support the evaluation. For definitions, see table 1. SK = Skagerrak–Kattegat, BP = Baltic Proper, GB = Gulf of Bothnia. The scores are based on a subjective evaluation of the cited literature and should be updated as new relevant results become available. Total scores are colour coded as: 3–4 = low, 5–6 = mod, 7–9 = high.

	Area	Spatial extent	Temporal extent	Sensitivity ^a	Total	Certainty
Acoustic disturbance (–)						
Marine mammals	SK	2–3	1	2–3	4–7	3
	BP	2–3	1	2–3	4–7	3
	GB	2–3	1	2–3	4–7	3
Fish	SK	2–3	1	2–3	4–7	3
	BP	2–3	1	1–2	4–6	3
	GB	2–3	1	1–2	4–6	3
Benthos	SK	2–3	1	1–2	4–6	1
	BP	2–3	1	1–2	4–6	1
	GB	2–3	1	1–2	4–6	1
Sediment dispersal (–)						
Marine mammals	SK	2	1	1	4	3
	BP	2	1	1	4	3
	GB	2	1	1	4	3
Fish	SK	2	1	2	5	2
	BP	2	1	2	5	2
	GB	2	1	1	4	2
Benthos	SK	2	1	1	4	3
	BP	2	1	1	4	3
	GB	2	1	1	4	3

^a The higher score refers to pile driving and the lower score to other activities (drilling, dredging).

Table 2-8: Example of a computation method of the environmental impact total score, applied to offshore wind farm [28]

To date, and mostly due to few ocean energy project deployment, there is very limited data on the marine environments impacted by these projects and therefore environmental impact assessments are mostly based on a qualitative approach ([29], [30]). Several European-funded projects already dealt with the evaluation of the environmental impact of renewable sources in marine environment. In the case of offshore wind, for example, the INTERREG IVa OFELIA project is noteworthy as it aimed at improving the understanding of the environmental impacts of offshore wind farm foundations (for additional details see [32]). In the field of marine energy, the aim of EquiMar [31] was to deliver a suite of protocols for the equitable environmental and economic impact evaluation of marine energy converters (based on either tidal or wave energy). H2OCEAN [33] studied the environmental impact assessment for an economically and environmentally sustainable multi-use wind-wave power open-sea platform from 2012 to 2014. Similarly, a specific task of MERiFIC [34] was dedicated to environmental assessment and issues, and in particular through a review of existing literature that summarizes and compares different conclusions from observation campaigns and monitoring reports, scientific articles and internet websites and therefore provides a key to understanding environmental impacts, proven or suspected, which are generated by marine energy extraction devices. The SOWFIA project [35] aimed to achieve the sharing and consolidation of pan-European experience of consenting processes and environmental and socio-economic impact assessment (IA) best practices for offshore wave energy conversion developments. The ongoing

RiCORE project[36] will establish a risk-based approach to consenting, where the level of survey requirement is based on the environmental sensitivity of the site, the risk profile of the technology, and the scale of the proposed project.

Environmental impact assessments of MRE development projects are also available. They provide different information about potential environmental impact assessment methodologies, usually in relation with specific regulation constraints. A non-exhaustive list is shown in Table 2-9.

Technology	Country	Projects
Tidal converters	UK [37]	Argyll Tidal Development
	UK [37]	Brims Tidal Array, Orkney
	UK [37]	DP Marine Energy - Islay Tidal Project
	UK [37]	EMEC - Fall of Warness
	UK [37]	GSK Montrose Tidal Array
	UK [37]	Kyle Rhea, Marine Current Turbines
	UK [37]	Lashy Sound Tidal Array
	UK [37]	MeyGen Phase 1, Pentland Firth
	UK [37]	Ness of Duncansby Tidal Array
	UK [37]	Sound of Islay
	Ireland [38]	SeaGen - Strangford Lough
	UK[37]	Westray South Tidal Array
	France [39]	Paimpol Bréhat
Wave converters	UK ¹	Aegir Wave Power - South West Shetland
	UK [37]	Aquamarine Power - Oyster Array
	UK [37]	Brough Head Wave Farm
	UK [37]	Costa Head Wave Farm
	UK [37]	Farr Point - Pelamis Wave Power
	UK [37]	Marwick Head Wave Farm
	UK [37]	North West Lewis Wave Array
	France	Semrev
	UK [37]	Siadar Wave Energy Project
	UK [37]	West Orkney South Wave Energy Site
UK [37]	Wavehub	

Table 2-9: List of European MRE projects for which information about the environmental impact assessment is available [37]–[39].

2.2.3 Reliability metrics and indicators

In order to navigate through the ‘valley of death’, better known as Technology Readiness Levels (TRLs) 4-6, towards commercial realisation it is necessary for new marine renewable energy technologies to be de-risked. Also, being able to prove overall device reliability can be a requirement of funding. For example, in order to obtain NER300 funding device developers must be able to demonstrate that their technology produces at least 75% of the production target specified on application [40]. This is influenced by device reliability [41] and will shape prospective device maintenance strategies [42]. Without prior long-term deployment experience setting such an important target is difficult, if not impossible, without first conducting reliability analysis supported by component and sub-system reliability testing [43], [44].

Method	Description	Input	Accuracy	Required resources	Example MRE studies
Bottom-up statistical	Widely used, with failure rates based on statistical curve fitting (i.e. exponential, normal or Weibull probability density functions) to field data	Component details (type, number), operating and environmental conditions	Relative	Small	[45], [46]
Top-down similarity	Used when detailed reliability data is available (i.e. databases). The method assumes that similar equipment can be used to predict the reliability of a new design and that the differences can be quantified	Failure rates of similar components, main differences	Absolute	Medium	[47]
Physics of failure	Used to identify principal failure mechanisms and requires detailed knowledge of the component (material, environment etc.) throughout the lifetime of the component	Material and design details, assembly processes, loading conditions and operating environment	Absolute	Large	[48], [49]

Table 2-10: Reliability assessment methods considered for MRE devices (adapted from [50])

A review of other projects has not revealed widely established methods to assess the reliability of MRE arrays, despite one recent SI Ocean report identifying reliability as one of ‘...the key factors for reducing the perception of technology risk’ [6] and another report naming ‘Reliability Modelling Tools’ as a ‘...current technology development need’[40]. Initial efforts to consider system reliability in the assessment of the cost of energy arrays have been put forward, for example The Carbon Trust’s *Marine Energy Challenge* [51] and operational logistics models (e.g. [52]), whilst others have focused instead on device power performance (e.g. [53]). Organisations such as the European

Marine Energy Centre and Det Norske Veritas have gone one stage further and recommended specific analysis techniques (e.g. Failure Modes Effects and Criticality Analysis, [44], [54]). A number of approaches to assessing individual device reliability have been proposed, often originating from automotive, aerospace (and more recently) wind turbine [55] sectors. These can be broadly split into three categories, as summarised in Table 2-10.

At array scale, the problem of reliability of offshore wind energy turbines was the object of deep discussions, at least since 2002, when the machines to be installed were still relatively small. Albeit it was clear that new, larger machines can lead to more profitable exploitation of the offshore wind potential [56], the reliability of the wind turbines used until then was not sufficient for such future large-scale wind farms at sites significantly farther away from shore. At that time, the conclusion was that only an integral approach to the reliability problem of the full farm could reach the compromise of providing a considerable amount of electric power produced in a reliable and cost-efficient way over the projected lifetime of the array. Essentially, for wind energy, the problem moved from providing a more reliable system to guaranteeing a certain availability level.

The failure rates of components and sub-systems generally decrease with time [57], following a short period of early, or ‘infant’ failures. This is later followed by a long period of random failures, with component life then culminating in a period of ‘wear-out’. The wind industry has several decades of operational data to draw from for reliability predictions, with commonly used for this purpose. However, the development of larger turbines with higher generating capacities has led to decreases in reliability [58]. Despite having a head-start on the MRE industry, the wind industry (in particular those involved with offshore wind turbines) therefore continues to face challenges [59]. Typically information about component faults and power interruptions are neither required nor made available upon request, not even for projects like ENDOW (Efficient Development of Offshore Wind Farms) [60]. This issue can be solved by keeping transparency in databases and protection of information [61]. Currently the major sources of reliability data are:

- 1) Wind scientific Measurement and Evaluation Programme (WMEP) – Denmark
- 2) Wind Stats Newsletter – Denmark
- 3) Elforsk database – Sweden
- 4) System performance, Availability and Reliability Trend Analysis (SPARTA) – United Kingdom

In addition to the sources listed above, efforts to establish a reliability database which has the same level of detail as the Offshore RELiability Data (OREDA®) database [62] have been proposed for the wind industry [61]. Over the past 34 years OREDA has been developed by several prominent oil and gas operators and comprises statistical information regarding component and sub-system failure modes and the consequences of a failure occurring. However, the reliability of offshore oil and gas

exploration equipment is not fully defined. A recent review of mooring line failures identified is reported [63], some of which were caused by unexpected failure modes [64]. Similar collaborations for data collection and modelling have recently been launched for tidal energy; TiPTORS (Tidal Turbine Power Take-Off Reliability Simulation programme, (Offshore Renewable Energy (ORE) Catapult, 2014) [65]).

2.3 NEEDS OF THE INDUSTRY

Currently, ocean energy is still in prototype testing stage. Even though tidal is ahead of wave in terms of TRL, as in the tidal sector some signs of technological convergence have already been achieved and more full-scale operational data and pre-commercial projects plan are available. Planning ocean energy array is still a very challenging and diverse process where lots of different issues need to be taken into account; therefore, there is an intrinsic need for the development of analysis and decision tools in order to facilitate the decision making process at this stage.

2.3.1 Planning and Assessment Tools

Looking at related industries, such as offshore wind, there are several tools covering several aspects of the design process in order to facilitate the planning of the wind energy arrays. Some of the most important tools for offshore wind analysis are:

- **FAST** is a publicly-available simulation tool for horizontal-axis wind turbines developed by the National Renewable Energy Laboratory (NREL) in North America. The FAST code was developed for the dynamic analysis of conventional fixed-bottom wind turbines, but has been extended with additional modules to enable fully coupled dynamic analysis of floating wind turbines. Even though it is not directly suitable for wind farm designs, its outputs can be used for this purpose.
- **GH Bladed** is an integrated software tool for calculating wind turbine performance and dynamic response, developed by Garrad Hassan in the UK. It was originally developed for the modelling of onshore fixed-bottom wind turbines, but has been extended to include hydrodynamic loading for the modelling of offshore wind turbines.
- **SIMO** (Simulation of Marine Operations) is a general-purpose time-domain program developed by MARINTEK for the modelling and simulation of offshore structures. It is used extensively to model motions and station keeping of floating structures in the offshore industry. The code has been extended to enable modelling of floating wind turbines by the addition of an external module for the simulation of rotor aerodynamic forces. SIMO has also been coupled with non-linear finite element code RIFLEX, also developed by MARINTEK,

a tailor-made code for the static and dynamic analysis of slender marine bodies such as risers and mooring lines.

- **ECN's tool** for operation and maintenance: Energy research Centre of the Netherlands (ECN) is one of the leading consultancy service providers for the O&M optimization of offshore wind farms. Their software, with over 15 years of development, can not only be used at a planning stage using long term yearly average but also to make estimates for relative short period of time (1, 2 to 5 years) based on a time domain approach. In the end, the tool allows the simulation of a wide range of maintenance activities (calendar based / predetermined, condition based and unplanned corrective) with a high level of details.
- **windPRO** (by EDM) is a module-based software package suited for project design and planning of both single wind turbines and large wind farms. windPRO is based on more than 25 years of experiences in development of user-friendly software tools for wind energy project development.

Most current tools rely on numerical modelling in order to assist the design of offshore wind turbines and predict power performance. On the other hand, as the ocean energy industry is still in its infancy, there are very few decision making tools, and they are mostly thematic (hydrodynamic, electrical, etc.). The most well know of the current tools are described below:

- **WEC-Sim** is an open-source wave energy converter (WEC) simulation tool. WEC-Sim has the ability to model devices that are comprised of rigid bodies, power-take-off systems, and mooring systems. Simulations are performed in the time-domain by solving the governing WEC equations of motion in 6 degrees-of-freedom. The WEC-Sim project is funded by the U.S. Department of Energy's Wind and Water Power Technologies Office and the code development effort is a collaboration between the National Renewable Energy Laboratory (NREL) and Sandia National Laboratories (SNL).
- **Wave-Farmer** is commercial software from DNV GL. The development, verification and validation of WaveFarmer has taken place as a part of the £8m ETI PerAWaT project, whose primary aim was to produce software tools that can help reduce uncertainties in marine energy projects and so increase confidence. WaveFarmer has a range of functionality designed to make planning arrays of wave energy converters as easy as possible.
- **TidalFarmer** is commercial software from DNV GL. The development, verification and validation of TidalFarmer have taken place as part of the £8m ETI PerAWaT project. TidalFarmer estimates energy yield for tidal energy arrays and includes validated wake models that capture the wake mixing processes downstream of multiple devices.

Other existing tools are available, even though they cannot be considered as “commercial products” in a strict sense. For instance, WavEC and INNOSEA have developed wave-to-wire tools with over 10 years of development. These tools have served a large number of device and project developers through consultancy and services over the past 10-15 years.

As can be seen from the aforementioned tools, most of them are dedicated to hydrodynamic numerical modelling of both tidal and wave energy converters. From these tools, the standard output would be the annual energy production as the focus on performance. However, it should be noted that this is only one parameter to take into account when making decisions on ocean energy arrays. Costs, reliability, environmental issues, site assessment are other key factors when planning an array deployment. Furthermore, it should be highlighted that currently, most tools are designed for the analysis of individual devices and they are not computationally efficient when planning arrays of hundreds of devices.

2.3.2 Device Performance Standardisation

Another important issue for industries engaged with the MRE sector is the need for convergence with regard to standardisation of the methodology used to evaluate the performance of wave/tidal energy devices.

As an example of where ocean energy lacks standardisation, consider that wind turbine certification is now common practice in the offshore wind industry. Every turbine, regardless of which company is supplying this turbine, has to go through a similar certification process. When the end user, usually a utility, purchases a turbine, they receive several documents that can be used as a basis for the contract between the turbine supplier and the utility. The turbine type certification, and the certificated power curve, can create some confidence on the future good performance, endurance, availability and reliability of the machine.

Currently in the wave and tidal sector, the suppliers cannot provide a certified power matrix/curve. The reality is that the industry lacks a standardised methodology to obtain, via numerical analysis or otherwise, the necessary data. An agreement must be reached in both sectors, for a standardised process. A tool which could be used for the performance assessment of marine arrays could benefit the progress of the sector, by increasing the data available for business purposes.

There are several other ongoing standardization initiatives within the MRE sector:

- The International Electrotechnical Commission – Technical Committee 114 Marine energy - Wave, tidal and other water current converters was created by IEC in 2007. The existing scope of the Technical Committee is to prepare international standards for marine energy conversion systems. For the moment this group has issued three documents, but it is expected the issue of new standards in the near future:
 - IEC/TS 62600-1 Edition 1.0 (2011-12-07) Marine energy - Wave, tidal and other water current converters - Part 1: Terminology
 - IEC/TS 62600-100 Edition 1.0 (2012-08-30) Marine energy - Wave, tidal and other water current converters - Part 100: Electricity producing wave energy converters - Power performance assessment
 - IEC/TS 62600-200 Edition 1.0 (2013-05-07) Marine energy - Wave, tidal and other water current converters - Part 200: Electricity producing tidal energy converters - Power performance assessment
- Equitable Testing and Evaluation of Marine Energy Extraction Devices in terms of Performance, Cost and Environmental Impact (EQUIMAR). The EquiMar project was funded by the European Commission as part of its 7th Framework programme under the Energy topic. It is a collaborative research and development project involving a consortium of 23 partners and ran for three years from the 15th of April 2008 to the 14th of April 2011.

The aim of EquiMar was to deliver a suite of protocols for the equitable evaluation of marine energy converters (based on either tidal or wave energy). These protocols have harmonised testing and evaluation procedures across the wide variety of devices presently available with the aim of accelerating adoption through technology matching and improved understanding of the environmental and economic impacts associated with the deployment of arrays of devices. EquiMar has assessed devices through a suite of protocols covering site selection, device engineering design, the scaling up of designs, the deployment of arrays of devices, the environmental impact, in terms of both biological & coastal processes, and economic issues. Results from the EquiMar project will establish a sound base for future marine energy standards. The project had a formal liaison with IEC TC 114 and many of the protocol authors are technical experts on the teams developing individual standards.

- Certification Process. Some certification companies are developing a certification process for wave and tidal devices. However they are still very immature and often certification process are tailored made for each Wave/Tidal energy converter. The lack of homogeneity in the certification process hampers the benchmark process between different certificated technologies.”

2.3.3 *Uncertainty Analysis*

Assessing the impact of uncertainty is common practise in the wind industry and is also important for the future development of the wave and tidal industry. Some parameters to be taken into account in an uncertainty analysis for the wind sector are:

- Site measurement
- Historic climate
- Vertical extrapolation (of environmental conditions)
- Future variability
- Spatial variation
- Plant performance losses this includes wake effect, availability, turbine performance, electrical losses

2.3.4 *Consultation*

Current ocean energy analysis tools cover just a part of the issues addressed above, and none of them offer a global decision making tool. Based on conversations with utilities such as Scottish Power and Vattenfall, it has become clear that in-house modelling is used for most of the processes in array planning, which requires an extensive use of human resources. The need of a state of the art global decision tool, integrating all the subsystems and addressing the key issues (in order to avoid in-house modelling, duplications and ineffectively spent resources), is clearly highlighted.

From these conversations with utilities, some elements were identified as key outputs from prospective decision tools: logistics, the success factor, transit risk, probability of vessel use and the probability of failure/waiting time among others. Other considerations include site planning, optimum number of devices for a specific lease, position of devices and the seasonal variations of the power output. These are the key parameters required to make informed decisions on array projects. DTOcean will fill the aforementioned gaps and the developed tool will provide the required information in order to make knowledgeable decisions.

3 CHARACTERIZATION OF SCENARIOS DEFINED IN WP1

DTOcean, since the initial Workshop Meeting which took place in Edinburgh on 27th November 2013 and during the first face-to-face WP held again in Edinburgh in February 2014, enabled discussion with industrial partners of the consortium for identifying which are the parameters mostly affecting the themes/scope of DTOcean platform and set of tools.

The discussion took into account the state-of-art of the sector, design criteria, and needs of the industry as described in section 2 of the present deliverable.

When an ocean energy project is considered as a scenario to validate the DTOcean tool, there is a wide range of parameters to choose from. Some of these are common to most projects while others may only relate to a small percentage of projects.

From that wide range, the selection of parameters was driven by:

- The importance of the physical constraints introduced by the chosen technology. (e.g. device operating depth);
- The parameters which would most affect the construction, installation and maintenance of the farm. (E.g. water depth at the site);
- Specific parameters which would impact permitting and grid connection issues: bathymetry, distance to shore, environmental constraints. When planning the layout of a marine farm a deep analysis of the bathymetry is required, in particular for tidal arrays, as the bathymetry influences significantly the resource.

D1.1 [1] of the project can be considered as a conclusion of this data gathering process and as a reference for beginning the technical work developed in each computational package of the global set of tools.

The detailed scope of the tool functionality is included in Table 1 of [1], and here reported in Table 3-1. On the left-hand side, the Table collects the input parameters for the array deployment which are considered more relevant from the scientific and technical community, given the experience of the partners, as reported in Sections 2.1 and 2.3 of this deliverable. Similarly, on the right-hand side in the Table, there is the range (lower and upper bound) for each parameter which will be covered within DTOcean in general. It was requested by all the technical developers of the tools to define the hydrodynamic / electrical / mooring and foundation / logistics and installation / operation and maintenance models taking into account these limits, not only because they are representative of the actual state in the sector, but also for the near-future perspective of usage of the tools.

Specific Scope parameters			
Array Size (MW)	<10-100		
Water Depth Tidal (m)	15-80		
Water Depth Wave (m)	12-200		
Seabed	Rock	Rock with Sediment	Sand and Muddy Sand
Single device rating (MW)	0.1-3		
Cable distance to shore (km)	0-50		
Load out distance (km)	0-2000		
Onshore distance (km)	0-50		
O&M distance (km)	0-100		

Table 3-1: Specific Scope parameters – Scenario in DTOcean Tool (as reported in Table 1 in D1.1 [1] of DTOcean Project).

More specifically, the following three wave technologies have been identified for deployment either nearshore or far offshore:

1. Fixed device;
2. Floating point absorber;
3. Floating attenuator.

Similarly, the tidal scenario of the tool, takes into account both a constrained channel (2-20km wide) environment and a headland flow in the open-ocean. The technologies identified to complete the tidal scenario are:

1. Horizontal axis fixed-ducted or un-ducted;
2. Floating;
3. Vertical axis fixed.

In the following subsections, the five validation cases selected during the first meetings of the projects are described. A last sub-section will list the three validation cases which have been chosen during the preparation of T1.5 and included in the deliverable D1.3.

Where data is not available from project partners or manufacturers, WP1 will attempt to get it from the following sources, in the following order:

- Publicly available documentation: information in environmental reports submitted to the consenting authorities by the site developers.
- Public Repositories: If a project partner is unable to provide bathymetry data, WP1 will attempt to access similar, representative data (relevant to a nearby location) through a publically available repository. For example the British Oceanographic Data Centre, BODC (<http://www.bodc.ac.uk/>) in the UK or Infomar (<http://www.infomar.ie/>) in Ireland. Similarly, if geotechnical data is not available, WP1 will try to identify similar data from a public source, for example the British Geological Survey website at <http://www.bgs.ac.uk/>
- Generic data: There is some generic data available from the more common device types; this may provide a source for power curve or power matrices for devices.
- Test data: If data from the sources listed above are not available, then we will generate test data, within reasonable ranges, to allow us to validate the tool.

3.1 VALIDATION CASE 1 (WAVE): North West Lewis

Aquamarine Power, with industry partners Scottish and Southern Energy and ABB Technology Ventures, are intending to develop a near-shore 40MW site on the north-western side of the island of Lewis, in the western Hebrides, Scotland. It is intended that Aquamarine Power will deploy an array of Aquamarine Oyster devices (extracted from D1.1 [1]). Further information can be found in the website of Aquamarine Power [66] or in Tethys [67], the knowledge management system that gathers, organizes, and provides access to information on the environmental effects of marine and hydrokinetic (MHK) and offshore wind energy development.



Figure 3-1: Oyster Technology for Validation Case 1 (image from [68]).

3.2 VALIDATION CASE 2 (TIDAL): Fair Head Tidal

DP Energy with project partners DEME Blue Energy, and associated technology suppliers, intend to build out a 100MW tidal energy project on the north east coast of Northern Ireland at Fair Head near Ballycastle. The preferred technology used for this location will be seabed mounted horizontal axis turbine however, floating tidal devices are also under consideration. The technology has not yet been confirmed, however, the devices currently under consideration are from Marine Current Turbine, Alstom TGL and Scotrenewables Tidal Power Ltd. (extracted from D1.1 [1]).

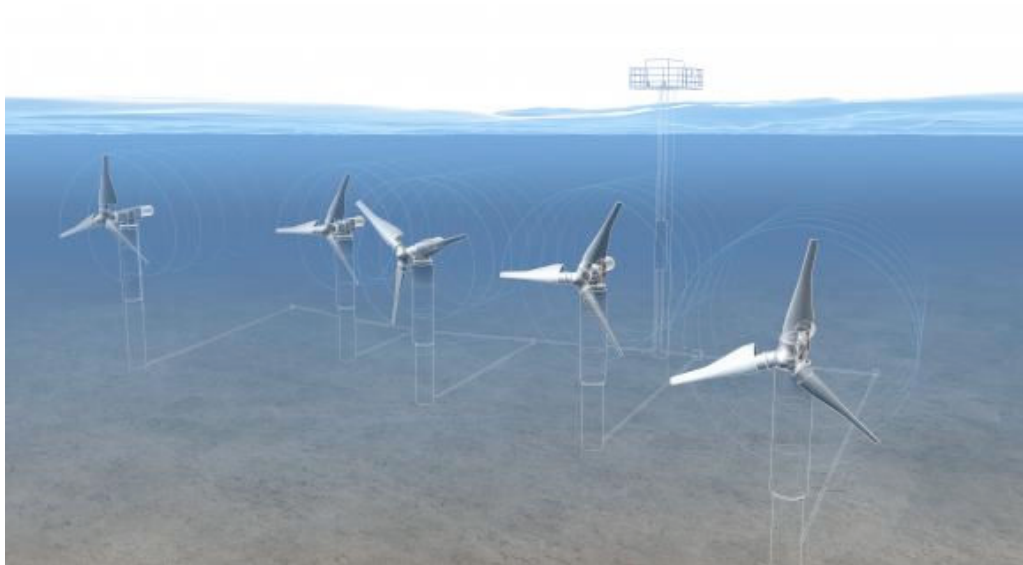

Figure 3-2: MCT Tidal Turbines for Validation Case (image from [69]).

3.3 VALIDATION CASE 3 (WAVE): Aegir Shetland Wave Farm

Pelamis Wave Power and Vattenfall have created a joint venture called Aegir Wave Power, the purpose of which is to develop commercial wave farms. A 10MW array, of Pelamis P2 floating attenuator devices, is currently in the planning stage. This development will be located offshore on the west coast of Shetland (extracted from D1.1 [1]).



Figure 3-3: Pelamis P2 Technology for Validation Case 3 (image from [70]).

3.4 VALIDATION CASE 4 (WAVE): WestWave

ESB International (ESBI) in Ireland are developing a small wave energy array under European Investment Bank supported NER300. ESBI is working with a consortia of developers, electricity providers and Government bodies to develop a 5MW array of wave energy converters. As for the technology, for DTOcean scope it was considered the RM3 device; a favoured site of the array is off the coast of west County Clare, Ireland. (extracted from D1.1 [1]).

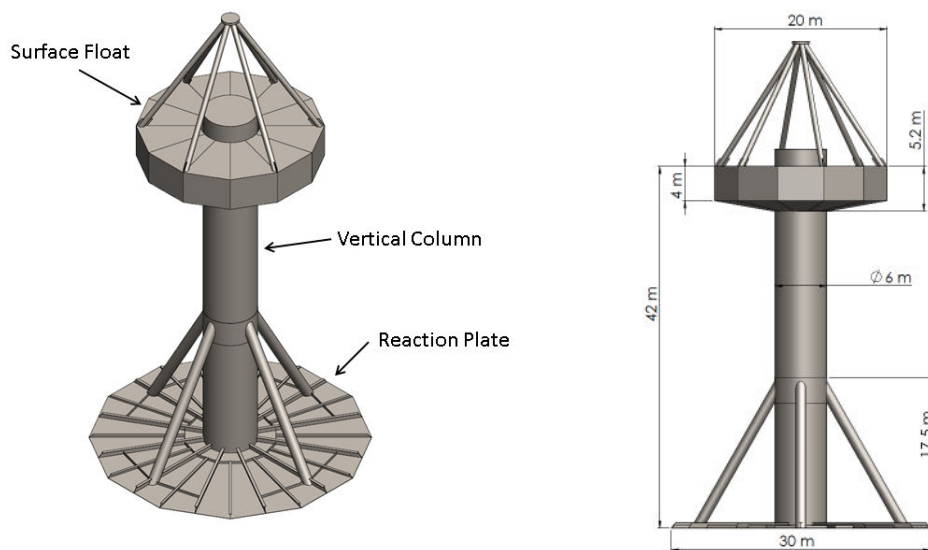

Figure 3-4: RM3 device design and dimensions, for Validation Case 4 (from [71])

3.5 VALIDATION CASE 5 (TIDAL): Sound of Islay

ScottishPower Renewables have applied to develop a 10MW tidal turbine demonstration array in the Sounds of Islay, between the islands of Islay and Jura on the west coast of Scotland. The technology has not yet been confirmed, however, the devices currently under consideration are the HS1000 developed by Andritz Hydro Hammerfest and Alstom's 1MW tidal turbine. (extracted from D1.1 [1]).

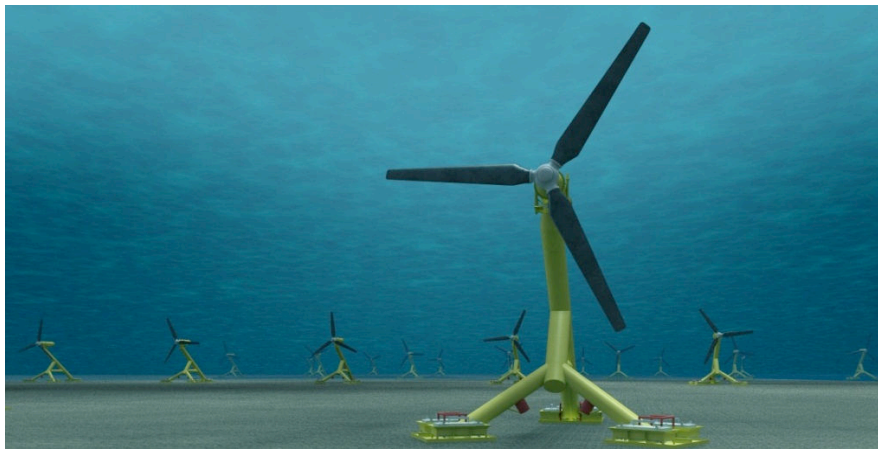

Figure 3-5: Andritz HS1000 tidal turbine for Validation Case 5 (image from [72]).

4 THEMATIC INDICATORS FOR EVALUATING MRE ARRAYS CONFIGURATIONS

A review of the indicators generally used for assessing energy converter arrays was undertaken in section 2 of this document. This section now provides an overview of the selection of parameters that will be used within the DTOcean tool.

4.1 ECONOMIC INDICATORS

The chosen economic indicator for DTOcean was the LCOE, as it has a widespread use both in industry and at a research level.

The knowledge of the market environmental conditions where the MRE technology will be assessed has an impact on the LCOE calculation through the discount rate. However, unlike detailed financial analysis, the LCOE is not influenced by the level of the feed-in-tariff, the local incentives (e.g. availability of capital grants) or the tax regimes. This relative neutrality of the LCOE with regards to the uncertain and volatile market environmental conditions can be seen as very attractive features for array design optimisation purposes which is one key objective of the DTOcean tool.

However, as mentioned before, the calculation of LCOE and other financial indicators follow the same rationale and use the same building blocks. In other words, it should be straightforward for the end-user of the DTOcean tool to transfer the results of the LCOE assessment in a financial sheet in order to consider the specific market conditions applying to the prospective project.

An assessment of the risks and the level of uncertainty associated with the results of a techno-economic analysis is also highly recommended. For this purpose, Monte Carlo analysis and other type of sensitivity analysis techniques are commonly implemented.

The following sections detail how the LCOE is to be used within the context of DTOcean, by addressing each of its main components.

4.1.1 *Annual Energy Production (AEP)*

The estimation of the annual energy production of an MRE system depends on the type of technology. The AEP may be obtained from numerical analysis, experimental testing and/or full scale data measurements. Hence, there is a wide variety of approaches to predict the AEP.

The most advanced tools in numerical analysis consider the performance of the device throughout the transmission chain as well as its availability by simulating all expected marine operations and O&M activities affecting the power production.

DTOcean shall provide sophisticated models accounting for the hydrodynamic interactions between devices, the electrical losses and the lifetime availability of an array of wave or tidal devices.

4.1.2 Capital Expenditures (CAPEX)

When no data is available from the manufacturer (or technology developer), the typical approach consists of making use of estimates and quotes for the components that can be found in other industries (e.g. mooring lines & anchors, electronics components, etc...). Alternatively, the costs of some appropriate components may be related to physical parameters in the design specifications, such as main structural components of a MRE device are generally based on the price of material and the geometry of the design.

DTOcean will rely upon its own customized database of components for the electrical infrastructure and the moorings/foundations sub-systems. Furthermore, a detailed approach of the cost breakdown for the devices will also be available for the end-user in possession of quotes and price estimates.

4.1.3 Operational Expenditures (OPEX);

Given the relative youth of the ORE industry, OPEX estimates are arguably the most difficult figures to assess. A conservative approach is to consider the OPEX as a share of the CAPEX or of the installed capacity. More sophisticated approaches would attempt to sum up estimates of the relevant operational costs (cost of parts, vessel daily rates, cost of insurances, etc...).

DTOcean shall feature a relatively complex model for the O&M simulations inspired from previous work developed by other tool developers in the offshore wind sector, such as the OMCE developed by the Energy Centre of the Netherlands [73].

4.2 ENVIRONMENTAL INDICATORS

A major challenge for the DTOcean project is to design a software tool that can provide an environmental impact assessments based on both qualitative and quantitative approaches.

As previously stated in section 2, the evaluation of the environmental impact results from the interaction between the intensity of the stressor and the sensibility of the receptor (see Figure 4-1).

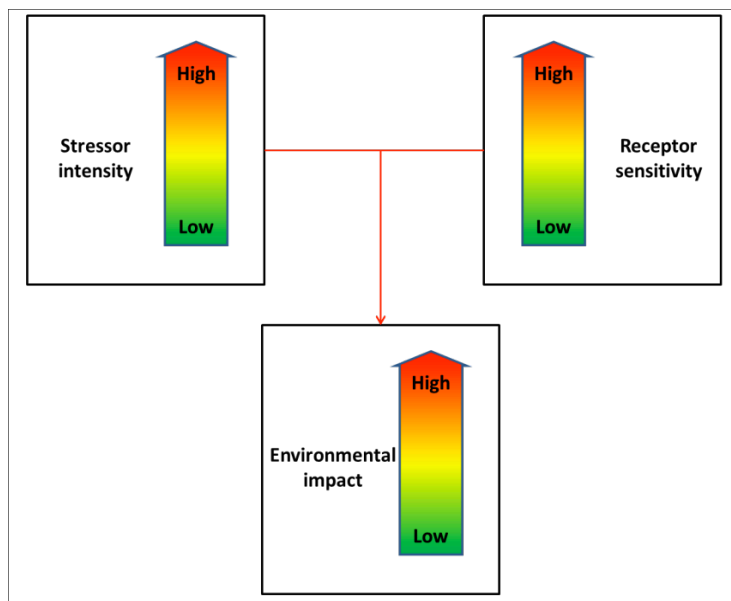

Figure 4-1. Main drivers used for the environmental impact assessment in the DTOcean tool

The innovation in the DTOcean project is that the environmental assessment tool should be able to provide detailed and overall 'environmental' scores similar to the ones described for the wind energy sector. The DTOcean environmental tool should also be able to quantify the intensity of the stressors by advanced mathematical functions. This is the first approach of this kind for MRE arrays as this environmental assessment tool is included in a global tool and directly related to the other components of the project (devices, electrical components, moorings ...).

As stated previously, in order to estimate the environmental impact of an ocean renewable energy project, two types of indicators are needed: the receptors which correspond to the marine environment compartments or parameters that may be affected by the second type of indicators, the stressors. These two types of indicators are described in the sections below.

4.2.1 Receptors: environmental compartments/parameters

This section describes the different compartments/parameters of the ecosystem, potentially impacted by the MRE arrays, which are considered for the environmental assessment within the DTOcean tool.

Physical compartments/parameters:

- Sediment: including the morphology of the seabed, the nature of the substrate and the sedimentary dynamics.
- Hydrodynamics: including currents and waves.
- Noise: with the characterization of the acoustic environment during the different stages of MRE project for underwater but also above the water.
- Temperature: water temperature is considered only here. To simplify the tool, the sediment temperature is not taken into account.
- Electromagnetic field: generated by cables with some potential impacts on fish and mammals.

Biological compartments/parameters:

- Birds: both marine and coastal species according to the fact that the MRE projects can be nearshore and offshore,.
- Marine mammals: all the species of cetaceans and pinnipeds.
- Fish: benthic, demersal and pelagic fish as well as larval, juvenile and adult stages.
- Plankton: phytoplankton and zooplankton.
- Benthos: seabed habitats and organisms living in close association with it.
- Ecosystem interactions: all the interrelations among the different receptors described just above within an ecosystem, like trophic relations [30] are considered here.

Chemical compartments/parameters:

- Chemical toxic substances: a preselected list of chemical toxic substances known to impact the environment.

4.2.2 *Stressors: environmental functions*

To evaluate the intensity of the stressors, 13 environmental functions have been defined overall. They are briefly presented in this section. The Figure 4-2 shows what functions are related to the different WPs.

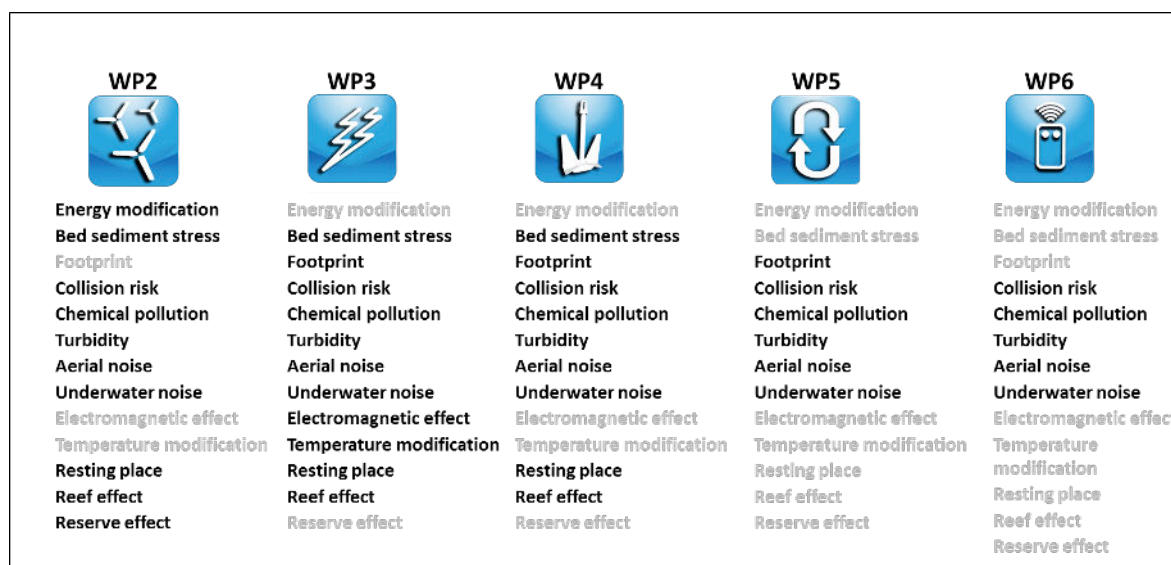

Figure 4-2: Summary of functions related to each WP.

The description of each function is given below with their specifications, application scope, related WP and project phase (e.g. installation or operation phase). Note that the impacted receptors are also linked to the stressor intensity and the impacted receptor sensibility in order to better assess the overall environmental impact.

Function name	Function description	WP	Project phase	Receptors	Examples of environmental impacts [65]
Energy modification	This function evaluates the extraction of energy (current and wave) due to the devices	WP2	Operation	Hydrodynamic Ecosystem Plankton Sediment	Impact on the water masses Modification of the deep and movement of the sediment Modification of species in the water column Wave propagation modification Attrition of energy through friction
Bed sediment stress	This function evaluates the modification of the sediment due to the presence of devices	WP2 WP3 WP4	Operation	Sediment Benthos	Increase of the turbidity Potential mobilization of chemical contaminants Increased of the oxygen demand Impact on the benthos

Footprint	This function evaluates the intensity of the direct destruction of benthos due to the foundations, electrical components or other components of the ocean energy project components	WP3 WP5	Installation Operation	Benthos	Destruction of habitats of interest Disturbance of the wildlife Species extinction Destruction of spawning area
Collision risk	This function evaluates the collision risk between the components of the project and mobile fauna that live or pass through the area	WP2 WP3 WP4 WP5 WP6	Operation	Mammals Birds Fish	Superficial wounds Death Habitat loss
Chemical pollution risk	This function evaluates the risk of chemical pollution (a list of selected pollutants is defined) due to the components of the project	WP2 WP3 WP4 WP5 WP6	Installation Operation	Toxic substances in the sea Ecosystem interactions	Habitat and species contamination Habitats change
Turbidity	This function evaluates the intensity of the modification of the turbidity due to the components of the ocean energy project	WP2 WP3 WP4 WP5 WP6	Installation Operation	Ecosystem interactions Plankton	Increased of the oxygen demand Impact on the benthos and plankton: species extinction, diminution of primary production
Aerial noise	This function evaluates the intensity of the pressure induced by the aerial noise produced by the components of the project	WP2 WP3 WP4 WP5 WP6	Installation Operation	Birds Noise	Negligible/no impacts Impacts (animals hear the noise, respond to the noise: orientation loss, habitat loss, habituation to noise, the animal's communications are masked by the noise: declining breeding, social relations etc.)

Underwater noise	This function evaluates the intensity of the pressure induced by the underwater noise produced by the components of the project	WP2 WP3 WP4 WP5 WP6	Installation Operation	Mammals Fish Noise	Negligible/no impacts Impacts (animals hear the noise, respond to the noise: orientation loss, habitat loss, habituation to noise, the animal's communications are masked by the noise : declining breeding, social relations etc.) Strong impacts (injuries or death of the animal)
Electromagnetic effect	This function evaluates the intensity of the pressure induced by the electromagnetic fields produced by the components of the project	WP3	Operation	Mammals Fish Benthos Electromagnetic field	Attraction/repulsion, behavioral modification of mammals and fish Impact on settled benthos species (poorly known)
Temperature modification	This function evaluates the intensity of the pressure induced by the temperature produced by the components of the project	WP3	Operation	Mammals Fish Benthos Temperature	Impact on settled benthos species (poorly known)
Resting place	This function evaluates the quantity of emerged parts of the components that can be used as resting places	WP2 WP3 WP4	Operation	Mammals Birds	Attraction of new population or/and new species There may be dangerous surfaces for species
Reef effect	This function evaluates the intensity of the reserve effect due to the colonized surface of the components of the project	WP2 WP3 WP4	Operation	Ecosystem interactions	Emergence of new species Increase of biological activity Emergence of new trophic relationship
Reserve effect	This function evaluates the intensity of the reserve effect due to the surface of the farm that is not allowed to fishery	WP2	Operation	Ecosystem interactions	Increase of biological activity Emergence of new trophic relationship

Table 4-1: Presentation of the environmental functions designed to assess the stressors intensity

4.3 RELIABILITY INDICATORS

The bottom-up statistical method has been selected for use in the Reliability Assessment sub-Module (RAM) of the DTOcean Tool. The rationale for selecting this approach is due to its relatively low computational requirements, widespread usage and flexibility with sparse data. It is acknowledged that whilst this is not the most detailed approach to reliability assessment, it is a good fit with the current state of the sector for first generation MRE arrays. The method can account for different system hierarchies, however all failures are treated as independent events (i.e. cascade failures are not considered).

Mean time to failure (MTTF), time to failure (TTF) and mean time between failures (MTBF, [51]) are widely used metrics of system, subsystem and component reliability and are dependent on several factors:

- The reliability of individual components as described by probability distribution functions and specified as failure rates. Exponential failure rates applicable to the ‘useful’ life of components will be used in the first instance.
- Any modification to the failure rate due to changes in manufacturing quality, operational environment or application stress.
- The inter-relationships between components and sub-systems (i.e. parallel and series relationships and redundancy).

Risk priority numbers (RPNs) are used to identify components or subsystems which are at risk, based on frequency of failure and failure severity level. Use of RPNs in the Tool is based upon NREL’s *MHK Technology Development Risk Management Framework* [74] and can be thought of as a simplified way of carrying out integrity management. Alternative approaches exist, such as the use of threat matrices [75] however this approach tends to be descriptive rather than quantitative.

Reliability assessments within the RAM will be based on three calculation scenarios related to confidence (mean, pessimistic and optimistic) and two calculation scenarios related to failure consequence (critical and non-critical¹). This will allow the user to ascertain the level of uncertainty associated with each estimation and also enable failure effects to be categorised, thus providing a simplified version of Failure Mode and Effects Analysis. Assuming that data is available for all scenarios, potentially the RAM will calculate reliability metrics a total of 6 times. Multiple calculation scenarios are widely used in the offshore industry (e.g. [62]) and have also been applied to MRE cost of energy analysis [51].

¹ In [62] three severity levels are specified (critical, degraded and incipient). Due to the present lack of data, only two severity levels will be used, critical and non-critical.

Table 4-2 lists the reliability indicators that will be produced by the DTOcean Tool and the modules which will use them.

Parameter	SI Unit	Usage					Comments
		User	WP3	WP4	WP6	WP7	
System Mean Time To Failure	Hours	X				X	System MTTF for three scenarios (mean, pessimistic, optimistic). Shown in the GUI tree.
Sub-system Mean Time To Failure	Hours	X				X	MTTF for all sub-systems for three scenarios (mean, pessimistic, optimistic). Shown in the GUI tree.
Component Time to Failure	Hours	X			X	X	Component TTF for three scenarios (mean, pessimistic, optimistic). Used by failure estimation module and presented to the user
Risk priority number	ND	X				X	Function of severity level and failure frequency. Shown for each level in the GUI tree
Percentage reliability	%	X				X	Calculated % of system reliability at end of mission

Table 4-2: Reliability indicators produced by the RAM

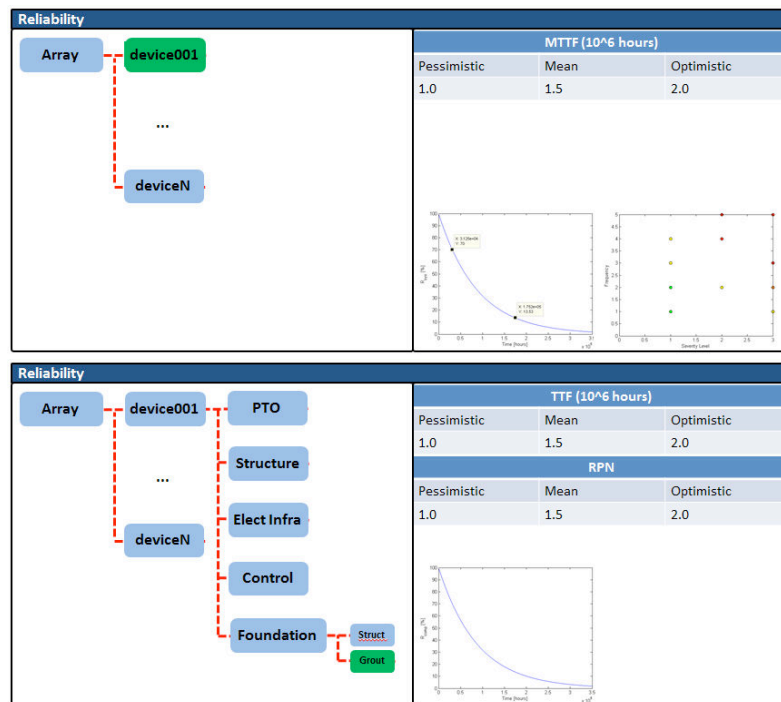

Figure 4-3: Possible GUI representation of array and device hierarchies and method of presenting MTTFs (or TTFs), percentage reliability over time and RPNs at (top) system and (bottom) component levels

The majority of parameters listed in Table 4-2 will be provided to the user to give an indication not only of overall system reliability but also the reliability of individual devices in the array and sub-system or component reliabilities at each system level. To display this effectively, the GUI might include an expandable tree structure with the array at the top level and components on the bottom level (e.g. Figure 4-3). The number of levels within the tree for each subsystem will depend on data availability. At each available system level the MTTF or TTF for the mean, pessimistic and optimistic calculation scenarios could be displayed and distinction made between critical and non-critical failure modes. Within the GUI, a system reliability (R_{sys}) distribution from deployment until mission end could also be plotted as well as a colour-coded RPN plot to assist the user in identifying components which have a high consequence of failure and/or failure frequency.

Component TTFs will be utilized by the failure estimation module of WP6 to enable random failure occurrences over time for each failure mode to be estimated. This will be used by the model to inform maintenance action scheduling. For these calculations, failures will be modelled using a Poisson process, a technique that has been adopted by the wind turbine sector [76].

5 CONCLUSIONS

This deliverable collates all of the key decisions made during the first 18 months of the DTOcean project, in terms of the drivers, parameter scope and indicators for the optimal design of ocean energy arrays. The choices have been justified through an exhaustive literature survey of analogous technologies (such as the offshore wind sector) whilst also examining the state of the art of contemporary marine renewable energy (MRE) projects.

In particular, five reference sites corresponding to the most advanced on-going deployment projects, in European waters, were defined during the first stages of the project. These five scenarios were chosen in order to cover the broadest range of design parameters within the scope of DTOcean and to provide a comprehensive set of data for validation of the suite of tools. The ranges of the input design variables are not only representative of the actual state of MRE sector, but also capture the near-future prospective use of the tools.

Because the design tool is multi-objective, in order to evaluate potential solutions the economic, reliability and environmental impact indicators and metrics have been chosen as follows:

- Economic Indicator: the Levelised Cost of Energy (LCOE) was selected because of its independence with respect to market conditions.
- Reliability Indicators: the users, through the GUI, will be informed of several parameters which attest the level of reliability for each sub-component of the overall system: System Mean Time to Failure (MTTF), subsystem MTTF, component Time to Failure, Risk Priority Number (RPN) and Percentage of Reliability.
- Environmental impact: after identifying the most sensitive receptors/stressors, environmental impact assessments of the MRE array will be calculated using the 13 environmental functions defined in section 4.2.

6 REFERENCES

- [1] “DTOcean - D1.1 - Detailed deployment scenarios for wave and tidal energy converters.” 2014.
- [2] “DOW DTOcean - contract 608597.” 2013.
- [3] E. Baddour, “ENERGY FROM WAVES AND TIDAL CURRENTS Towards 20yy?,” 2004.
- [4] W. Cooper, A. Salter, and P. Hodgetts, “Guidelines for the use of metocean data through the life cycle of a marine renewable energy development,” London, CIRIA C666, 2008.
- [5] Ernst & Young LLP, “Cost of and financial support for wave, tidal stream and tidal range generation in the UK.” 2010.
- [6] “D3.2 - SI-Ocean Project Ocean Energy: Cost of Energy and Cost Reduction Opportunities.” .
- [7] D. Dunnett and J. S. Wallace, “Electricity generation from wave power in Canada,” *Renew. Energy*, vol. 34, no. 1, pp. 179–195, Jan. 2009.
- [8] D. Jarocki and J. H. Wilson, “Wave Energy Converter Performance Modeling and Cost of Electricity Assessment,” in *ASME 2010 International Mechanical Engineering Congress and Exposition*, 2010, pp. 333–342.
- [9] C. A. Douglas, G. P. Harrison, and J. P. Chick, “Life cycle assessment of the Seagen marine current turbine,” *Proc. Inst. Mech. Eng. Part M J. Eng. Marit. Environ.*, vol. 222, no. 1, pp. 1–12, Jan. 2008.
- [10] EWEA - European Wind Energy Association, “The Economics of Wind Energy,” 2010.
- [11] W. Short, D. J. Packey, and T. Holt, *A manual for the economic evaluation of energy efficiency and renewable energy technologies*. University Press of the Pacific, 2005.
- [12] A. Babarit, J. Hals, M. J. Muliawan, A. Kurniawan, T. Moan, and J. Krokstad, “Numerical benchmarking study of a selection of wave energy converters,” *Renew. Energy*, vol. 41, pp. 44–63, May 2012.
- [13] G. Trowse, “FINANCIAL EVALUATION AND COST OF ENERGY.”
- [14] M. Giberson, “Assessing Wind Power Cost Estimates.” Oct-2013.
- [15] R. Wiser, E. Lantz, M. Bolinger, and M. Hand, “Recent developments in the levelized cost of energy from us wind power projects,” *Present. Submitt. IEA Task*, vol. 26, 2012.

-
- [16] A. Raventos, A. Sarmento, F. Neumann, and N. Matos, “Projected deployment and costs of wave energy in Europe. In,” in 3rd International conference on ocean energy, 2010.
- [17] B. Teillant, P. Chainho, A. Raventos, V. Nava, H. Jeffrey, W.-O. Renewables, and T. Energia, “A DECISION SUPPORTING TOOL FOR THE LIFECYCLE LOGISTICS OF OCEAN ENERGY ARRAYS.”
- [18] C. Beels, P. Troch, J. P. Kofoed, P. Frigaard, J. Vindahl Kringelum, P. Carsten Kromann, M. Heyman Donovan, J. De Rouck, and G. De Backer, “A methodology for production and cost assessment of a farm of wave energy converters,” *Renew. Energy*, vol. 36, no. 12, pp. 3402–3416, Dicembre 2011.
- [19] L. Castro-Santos, G. P. Garcia, A. Estanqueiro, and P. A. P. S. Justino, “The Levelized Cost of Energy (LCOE) of wave energy using GIS based analysis: The case study of Portugal,” *Int. J. Electr. Power Energy Syst.*, vol. 65, pp. 21–25, Feb. 2015.
- [20] M. O’Connor, T. Lewis, and G. Dalton, “Techno-economic performance of the Pelamis P1 and Wavestar at different ratings and various locations in Europe,” *Renew. Energy*, vol. 50, pp. 889–900, Feb. 2013.
- [21] M. Previsic, O. Siddiqui, and R. Bedard, “Guideline Economic Assessment Methodology for Offshore Wave Power Plants,” 2004.
- [22] T. Stallard, R. Rothschild, and G. A. Aggidis, “A comparative approach to the economic modelling of a large-scale wave power scheme,” *Eur. J. Oper. Res.*, vol. 185, no. 2, pp. 884–898, Mar. 2008.
- [23] T. W. Thorpe, “An overview of wave energy technologies: status, performance and costs,” *Wave Power Mov. Commer. Viability*, vol. 26, pp. 50–120, 1999.
- [24] C. M. Johnstone, D. Pratt, J. A. Clarke, and A. D. Grant, “A techno-economic analysis of tidal energy technology,” *Renew. Energy*, vol. 49, pp. 101–106, Enero 2013.
- [25] G. Allan, M. Gilmartin, P. McGregor, and K. Swales, “Levelised costs of Wave and Tidal energy in the UK: Cost competitiveness and the importance of ‘banded’ Renewables Obligation Certificates,” *Energy Policy*, vol. 39, no. 1, pp. 23–39, Enero 2011.
- [26] G. J. Allan, P. Lecca, P. G. McGregor, and J. K. Swales, “The economic impacts of marine energy developments: A case study from Scotland,” *Mar. Policy*, vol. 43, pp. 122–131, Enero 2014.
- [27] D. Wilhelmsson, *Greening blue energy: identifying and managing the biodiversity risks and opportunities of offshore renewable energy*. Gland, Switzerland: IUCN, 2010.

- [28] L. Bergström, L. Kautsky, T. Malm, R. Rosenberg, M. Wahlberg, N. Åstrand Capetillo, and D. Wilhelmsson, “Effects of offshore wind farms on marine wildlife—a generalized impact assessment,” *Environ. Res. Lett.*, vol. 9, no. 3, p. 034012, Mar. 2014.
- [29] G. W. Boehlert and A. B. Gill, “Environmental and ecological effects of ocean renewable energy development: a current synthesis,” 2010.
- [30] B. Polagye, B. Van Cleve, A. Copping, and K. Kirkendall, “Environmental Effects of Tidal Energy Development: Proceedings of a Scientific Workshop March 22-25, 2010,” U.S. National Oceanographic and Atmospheric Administration, Technical Report, Apr. 2011.
- [31] “EquiMar.” [Online]. Available: <http://www.equimar.org/>. [Accessed: 23-Mar-2015].
- [32] “OFELIA.” [Online]. Available: <http://www.unicaen.fr/recherche/ofelia/?lang=en>. [Accessed: 23-Mar-2015].
- [33] “H2Ocean.” [Online]. Available: <http://www.h2ocean-project.eu/>. [Accessed: 23-Mar-2015].
- [34] “MERiFIC | Marine Energy in Far Peripheral and Island Communities.” .
- [35] “SOWFIA.” [Online]. Available: <http://www.sowfia.eu/>. [Accessed: 23-Mar-2015].
- [36] “RiCORE,” RiCORE. [Online]. Available: <http://ricore-project.eu/>. [Accessed: 23-Mar-2015].
- [37] S. A. H. Scottish Government, “Scottish Government - Current Projects,” 08-Dec-2009. [Online]. Available: <http://www.gov.scot/Topics/marine/Licensing/marine/scoping>. [Accessed: 23-Mar-2015].
- [38] “Environmental Aspects | SeaGeneration.” [Online]. Available: <http://seageneration.co.uk/environmentalaspects.php>. [Accessed: 23-Mar-2015].
- [39] “Protection de l’environnement sur le site de Paimpol-Bréhat - EDF.” [Online]. Available: <http://energie.edf.com/hydraulique/energies-marines/carte-des-implantations-marines/parc-hydrolien-de-paimpol-brehat/environnement-51534.html>. [Accessed: 23-Mar-2015].
- [40] A. MacGillivray, H. Jeffrey, D. Magagna, A. Raventos, and A. Badcock-Broe, “MacGillivray, A., Jeffrey, H., Hanmer, C., Magagna, D., Raventos, A., Badcock-Broe, A., 2013, Ocean Energy Technology: Gaps and Barriers, Published by SI Ocean; www.si-ocean.eu.” SI-Ocean, 2013.
- [41] J. Wolfram, “On Assessing the Reliability and Availability of Marine Energy Converters: The Problems of a New Technology,” *Proc. Inst. Mech. Eng. Part O J. Risk Reliab.*, vol. 220, no. 1, pp. 55–68, Jun. 2006.

-
- [42] K. Abdulla, J. Skelton, K. Doherty, P. O’Kane, R. Doherty, G. Bryans, and others, “Statistical availability analysis of wave energy converters,” in Proceedings of the 21rd international offshore and polar engineering conference. Hawaii, USA, 2011.
- [43] S. Weller, P. Thies, T. Gordellier, P. Davies, and L. Johanning, “The Role of Accelerated Testing in Reliability Prediction,” in Proceedings of the 11th European Wave and Tidal Energy Conference, Nantes, France, 2015.
- [44] Det Norske Veritas (DNV), “Certification of Tidal and Wave Energy Converters.,” DNV-OSS-312, 2008.
- [45] P. R. Thies, G. H. Smith, and L. Johanning, “Addressing failure rate uncertainties of marine energy converters,” *Renew. Energy*, vol. 44, pp. 359–367, Agosto 2012.
- [46] P. R. Thies, “Advancing reliability information for Wave Energy Converter,” Ph.D. Thesis, Univ. of Exeter, Exeter, UK, 2012.
- [47] T. M. Delorm, D. Zappalà, and P. J. Tavner, “Tidal stream device reliability comparison models,” *Proc. Inst. Mech. Eng. Part O J. Risk Reliab.*, vol. 226, no. 1, pp. 6–17, Feb. 2012.
- [48] L. M. Yang, J. Hals, and T. Moan, “A wear model for assessing the reliability of wave energy converter in heave with hydraulic power take-off,” in Proceedings of the Eighth European Wave and Tidal Energy Conference, Uppsala, Sweden, 2009.
- [49] C. Iliev and D. Val, “Tidal current turbine reliability: power take - off train models and evaluation,” in 3rd International Conference on Ocean Energy, Bilbao, Spain, 2010.
- [50] B. Foucher, J. Boullié, B. Meslet, and D. Das, “A review of reliability prediction methods for electronic devices,” *Microelectron. Reliab.*, vol. 42, no. 8, pp. 1155–1162, Agosto 2002.
- [51] Entec UK Ltd, “Cost estimation methodology. The Marine Energy Challenge approach to estimating the cost of energy produced by marine energy systems,” 2006.
- [52] B. Teillant, R. Costello, J. Weber, and J. Ringwood, “Productivity and economic assessment of wave energy projects through operational simulations,” *Renew. Energy*, vol. 48, pp. 220–230, Dicembre 2012.
- [53] J. F. Chozas, J. P. Kofoed, and N. E. Jensen, “User guide – The COE Calculation Tool for Wave Energy Converters. Version 1.6 - April 2014. (1 ed.),” Department of Civil Engineering, Aalborg, Denmark, DCE Technical Reports; No. 161, 2014.

- [54] M. Starling, Guidelines for reliability, maintainability and survivability of marine energy conversion systems: marine renewable energy guides. Orkney: European Marine Energy Centre, 2009.
- [55] P. Tavner, Offshore Wind Turbines: Reliability, availability & maintenance, IET. 2012.
- [56] G. J. W. Van Bussel, “Offshore wind energy, the reliability dilemma,” in Proceedings of the International conference, 2002, pp. 2–6.
- [57] E. Echavarria, T. Tomiyama, G. J. W. Van Bussel, and B. Hahn, “How Has Reliability Of Technology Developed Through Time?,” in Proceedings of International European Wind Energy Conference, Milan, May 2007, 2007.
- [58] M. Lange, M. Wilkinson, and T. van Delft, “Wind Turbine Reliability Analysis,” DEWEC Brem., 2011.
- [59] R. Perveen, N. Kishor, and S. R. Mohanty, “Off-shore wind farm development: Present status and challenges,” Renew. Sustain. Energy Rev., vol. 29, pp. 780–792, Jan. 2014.
- [60] G. Schepers, R. Barthelmie, K. Rados, B. Lange, and W. Schlez, “Large Off-Shore Windfarms: Linking Wake Models with Atmospheric Boundary Layer Models,” Wind Eng., vol. 25, no. 5, pp. 307–316, Sep. 2001.
- [61] Z. Hameed, J. Vatn, and J. Heggset, “Challenges in the reliability and maintainability data collection for offshore wind turbines,” Renew. Energy, vol. 36, no. 8, pp. 2154–2165, Agosto 2011.
- [62] S. T. and S. (Trondheim), OREDA: Offshore Reliability Data. OREDA Participants, 2009.
- [63] K. Ma, H. Shu, P. Smedley, D. L'Hostis, and A. Duggal, “A Historical Review on Integrity Issues of Permanent Mooring Systems,” 2013.
- [64] Noble Denton Europe Limited, “Floating production system JIP FPS mooring integrity,” 2006.
- [65] “Tidal turbine powertrain reliability project - Offshore Renewable Energy Catapult.” [Online]. Available:
https://ore.catapult.org.uk/home?p_p_id=101&p_p_lifecycle=0&p_p_state=maximized&p_p_mode=view&_101_struts_action=%2Fasset_publisher%2Fview_content&_101_returnToFullPageURL=%2F&_101_assetEntryId=166923&_101_type=content&_101_urlTitle=tidal-turbine-powertrain-reliability-project&redirect=https%3A%2F%2Fore.catapult.org.uk%2Fhome%3Fp_p_id%3D3%26p_p_lifecycle%3D0%26p_p_state%3Dmaximized%26p_p_mode%3Dview%26_3_groupId%3D10619%26

- 3_keywords%3Dtidal%2Bturbine%26_3_struts_action%3D%252Fsearch%252Fsearch%26_3_redirect%3D%252F&inheritRedirect=true. [Accessed: 10-Apr-2015].
- [66] “Aquamarine Power - Wave energy in Lewis.” [Online]. Available: <http://www.aquamarinepower.com/projects/north-west-lewis/>. [Accessed: 24-Feb-2015].
- [67] “North West Lewis Wave Array | Tethys.” [Online]. Available: <http://mhk.pnl.gov/annex-iv-sites/north-west-lewis-wave-array>. [Accessed: 24-Feb-2015].
- [68] K. Fehrenbacher, “Aquamarine Power Awash in \$17.4M,” 24-Nov-2010. .
- [69] “Siemens welcomes latest boost to tidal technology.” [Online]. Available: <http://www.marineturbines.com/News/2014/07/08/siemens-welcomes-latest-boost-tidal-technology>. [Accessed: 21-Apr-2015].
- [70] “Pelamis Wave Power : EMEC: European Marine Energy Centre.” .
- [71] Sandia, “Methodology for Design and Economic Analysis of Marine Energy Conversion (MEC) Technologies,” 2014.
- [72] “Tidal Energy,” Islay Energy Trust. .
- [73] L. Rademakers, H. Braam, T. S. Obdam, and R. P. vd Pieterman, “Operation and maintenance cost estimator (OMCE) to estimate the future O&M costs of offshore wind farms,” in Proc. of European Offshore Wind 2009 Conference, Stockholm, Sweden, 2009, pp. 14–16.
- [74] National Renewable Energy Laboratory, “MHK Technology Development Risk Management Framework - Draft,” 2014.
- [75] J. Baker, “Applying the threat matrix to investigate reliability and maintainability requirements of offshore renewable energy devices,” Underw. Technol. Int. J. Soc. Underw., vol. 32, no. 3, pp. 199–206, Nov. 2014.
- [76] V Slimacek and BH Lindqvist, “Failure rate of wind turbines modeled by Homogeneous Poisson Process with covariates and unobserved heterogeneity,” in Safety, Reliability and Risk Analysis, 0 vols., CRC Press, 2013, pp. 1229–1233.

7 ACRONYMS

AEP	Annual Energy Production
CAPEX	Capital Expenditure
CF	Cashflow
DoW	Description of Work
DPBP	Discount Pay-Back Period
EIA	Environmental Impact Assessment
EU	European Union
EWEA	European Wind Energy Association
GUI	Graphic User Interface
LCOE	Levelised Cost of Energy
MHK	Marine Hydrokinetic
MRE	Marine Renewable Energy
MTTF	Mean Time To Failure
MTBF	Mean Time Between Failure
NREL	National Renewable Energy Laboratory (USA)
NPV	Net Present Value
OEC	Ocean Energy Converter
OPEX	Operational Expenditure
ORE	Ocean Renewable Energy
OWF	Offshore Wind Farm
O&M	Operation and Maintenance
ORE	Ocean Renewable Energy

OWF	Offshore Wind Farm
RAM	Reliability Assessment Module (when specified)
RAMS	Reliability, Availability, Maintainability and Safety (not to be confused with RAM)
RPN	Risk Priority Number
SPA	Strategic Protected Area
TTF	Time To Failure
WACC	Weighted Average Cost of Capital
WEC	Wave Energy Converter
WP	Work Package
G&B	Green & Blue
PV	Photovoltaic